

CORNING

The future flows through Corning® Advanced-Flow™ reactors

Corning® Advanced-Flow™ G3 Reactor

A seamless and direct solution from lab to production

Corning has developed a high-flow-rate reactor for chemical production that retains the outstanding mixing and heat exchange performance of its lower-scale Advanced-Flow™ reactors while also providing:

- Large internal volume
- High flexibility
- Metal-free reaction path
- Scalability: Throughput factor increase of > 10 from G1 to G3
- Processing capability up to 100 kg/h

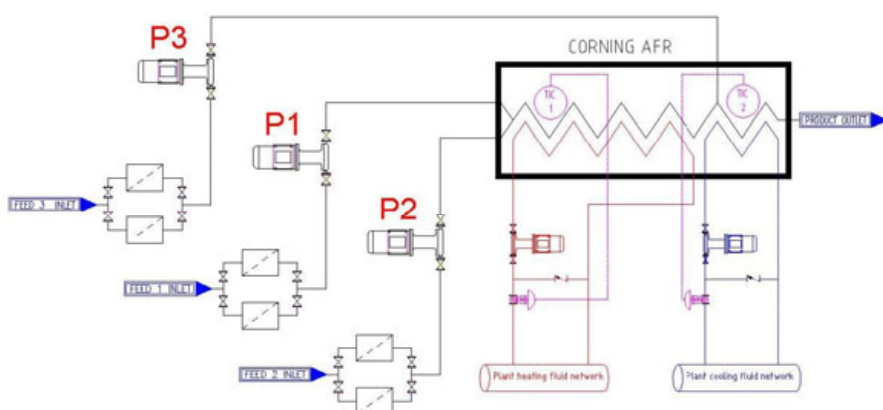
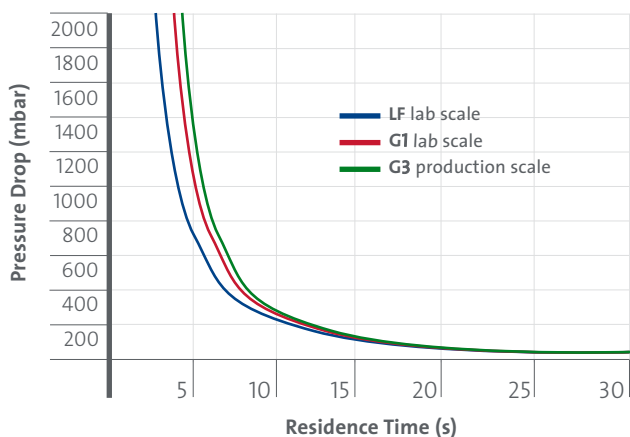

Integration of Corning® Advanced-Flow™ G3 Reactor in Production Plant

Example of Processing Capability

Reactor Characteristics	
Total pressure drop Process path (Approx.) (barg)	5 (*)
Total pressure drop Heat exchange path (Approx.) (barg)	2 (**)
Total internal volume (Approx.) (L)	0.8

(*) water 20°C, 100 kg/h total flow rate
 (**) water 20°C, 1500 kg/h total flow rate

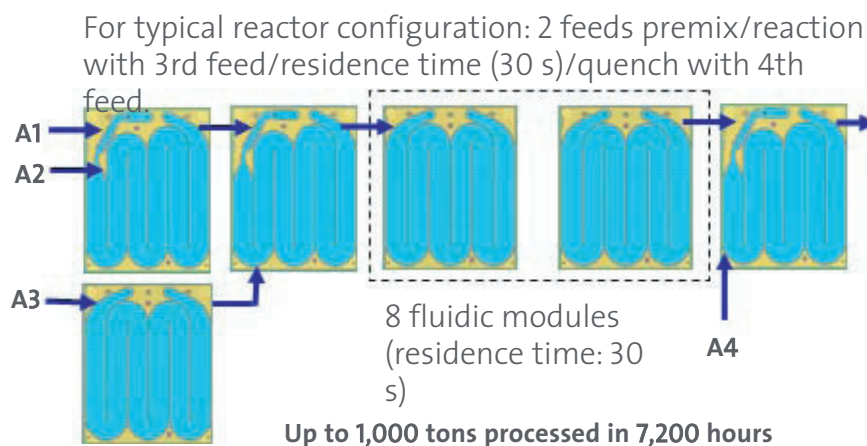

Reactor Elements

The G3 reactor is composed of borosilicate glass fluidic modules, PFA piping, perfluoro-elastomer gaskets and a full stainless steel frame compatible with the chemical production environment.

Boundary Conditions

Operating Range	Process Path	Heat Exchange Path
Temperature (°C)	-60 up to 200	-60 up to 200
Pressure (barg)	Up to 18	Up to 6

Various Fluidic Module Designs Available

Mixing Designs	Residence Time Designs
1 injection zone to contact 2 reactants and Residence time Heat exchange integrated	Residence time or Pre-heating/cooling Heat exchange integrated

To request information:

EMEA and NSA

Corning S.A.S.
 Reactor Technologies
 7 bis Avenue de Valvins
 CS 70156 Samois sur Seine
 77215 Avon Cedex, France

t + 33 1 64 69 71 07
 f + 33 1 64 69 70 59
 reactors@corning.com

China

Corning China (Shanghai) RHQ
 No 358, Lu Qiao Road, Jinqiao
 Export Processing Zone, Pudong,
 Shanghai 201206, China

+ 86 021 22152888* 1408
 + 86 21 62152988
 reactor.asia@corning.com

India

Corning Technologies India Pvt. Ltd.
 2nd Floor, DLF Building 9B
 DLF Cyber City Phase III
 Gurgaon, Haryana 122002, India

t + 91 124 4604000
 f + 91 124 4604099
 reactor.asia@corning.com