

Low Signal Latency in Optical Fiber Networks

WP8080

Issued: March 2, 2011

Author: John Jay

ISO 9001 REGISTERED

Because of the proliferation of such applications as high frequency trading, customers are demanding optical communications services with low signal latency. Therefore it is critical to consider all means of reducing latency when designing an optical communication network. The solution set is incomplete without a low latency optical fiber like Corning® SMF-28® ULL fiber.

Latency is the elapsed time between sending and receiving a message in an actionable form. Low latency is important whenever action on the message is time sensitive.

The most common low latency application today is high frequency trading by the financial services industry where trades are initiated instantaneously by computer programs that respond to market information. To advantage themselves in this market, financial services companies co-locate data centers with exchanges to improve trading response, and global long haul networks promote lower network latency between major financial hubs like London to New York.

Low latency becomes a critical design element for these customers' networks. Designers have several tools to reduce latency. The common theme is to challenge any component of the network, system or signal that delays the ability of the receiver to act upon the information contained in the message.

Schematic Diagram of an Example Long Haul Network. Each Network Element Presents an Opportunity to Reduce Latency.

Figure 1

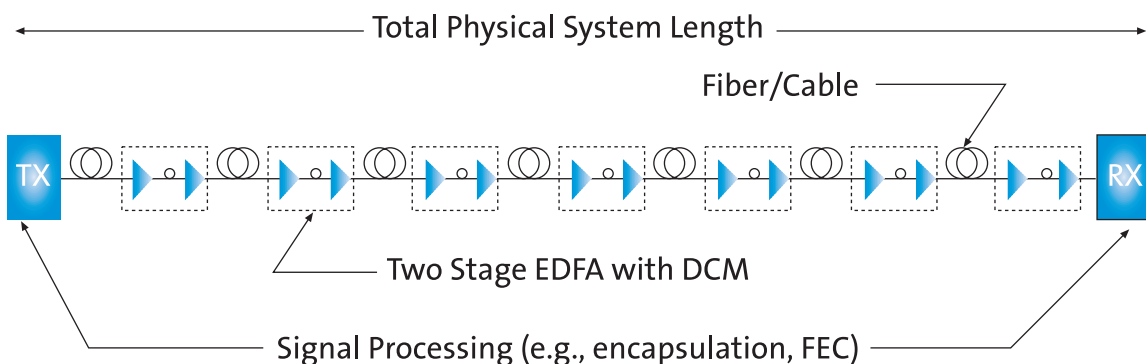

Several examples of techniques used to reduce latency can be seen in Figure 1.

- The system is installed along the shortest practical distance between the sender and receiver. Discipline must be maintained to adhere to the designated route regardless of difficulties in construction, permitting, installation, etc.
- Several techniques are used to reduce the excess optical path vs. physical path length.
 - Fiber dispersion is compensated by Fiber Bragg Grating (FBG) rather than Dispersion Compensating Fiber (DCF) avoiding the optical path increase of the DCF coils.
 - The signal is amplified using Raman amplification rather than inserting Erbium Doped Fiber Amplifiers (EDFA) which increase the optical path due to the EDF coils.
 - Excess fiber length (EFL) in the optical cable is reduced to minimize the optical path length. Ribbon cable or central tube designs with little EFL are good candidates for low latency applications.
 - Excess spare cable deployed in “slack loops” or coiled at splice points is minimized.
- Advanced signal processing techniques such as Forward Error Correction (FEC) are not used, avoiding the delay associated with signal processing.

After addressing all the above sources, the designer faces the major component of latency in long haul networks - delay of the optical signal in the fiber itself. This delay is determined by the signal “group velocity” – the speed of signal propagation in the fiber which depends upon the fiber group index.

$$v_g = c/n_g$$

Where, v_g is the group velocity (e.g., m/s) c is the speed of light in vacuum space (2.997925×10^8 m/s), and n_g is the group index.

Corning® SMF-28®ULL fiber has lower group index to outperform other fibers in low latency applications. SMF-28 ULL fiber has a silica core, with no germania which is commonly used to increase refractive index. Table 1 compares the 1550 nm group indices for SMF-28 ULL fiber and several other common commercially available optical fibers. With the lowest group index, SMF-28 ULL has the lowest latency.

1550 nm Group Indices for Common Commercially Available Single-Mode Fibers

Table 1

Corning® SMF-28® ULL Fiber	Corning® SMF-28e+® Fiber	Corning® LEAF® Fiber	Commercial NZDF fibers
1.4620	1.4679	1.4684	1.470

In addition SMF-28 ULL fiber has the lowest average attenuation of commercially available terrestrial optical fibers, <0.170 dB/km at 1550 nm. This will improve Optical Signal to Noise Ratio (OSNR) and offset the inability to use FEC to improve Bit Error Ratio (BER), as well reduce the amount of amplification necessary. Since SMF-28 ULL fiber complies with ITU-T Rec. G.652, it ensures compatibility with legacy network plant.

In summary, customers are demanding low signal latency for the optical communications services. Therefore designers must use all available tools to reduce latency when planning networks. This includes Corning SMF-28 ULL fiber as the low latency optical fiber choice.

Corning Incorporated
www.corning.com/opticalfiber

One Riverfront Plaza
Corning, New York
USA

Phone: (607)248-2000
Email: cofic@corning.com

Corning is a registered trademark and SMF-28e+ is a trademark of Corning Incorporated, Corning, N.Y.

© 2011, Corning Incorporated