



CORNING

DELL Technologies

10G to 800G Cabling Guide

For DELL Optical Transceivers

1. Understanding the Transceiver Types

This Cabling Guide will discuss the different available fiber optic connectivity to work with 10G, 25G, 40G, 100G, 200G, 400G and 800G, and breakout options within the same rack or row, and across the data center utilizing DELL switch capabilities.

With the introduction of AI/ML and High-Performance Computing (HPC), DELL has developed transceiver modules that utilize 16-fibers with connector types like MPO-16 APC, found on QSFP56-DD and OSFP112 modules, and Twin (dual) MPO-8/12 APC optical interfaces utilizing 2x 8-fiber, found on OSFP112 modules.

The main DELL transceivers by connector type:

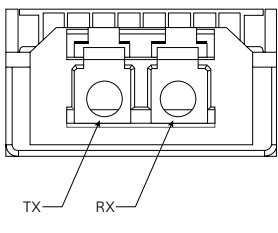
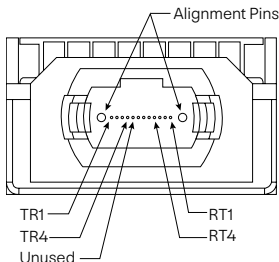
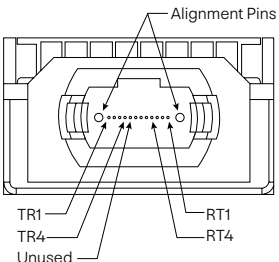
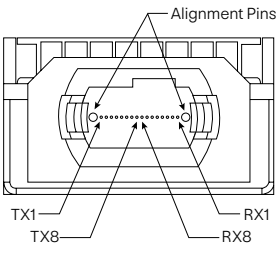
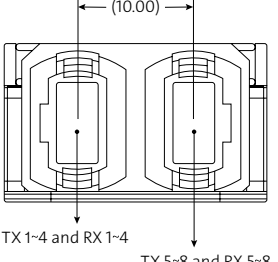
LC Duplex Interface	MPO-8/12 PC Interface	MPO-8/12 APC Interface	MPO-16 APC Interface	2x MPO-8/12 APC Interface
Single-mode				
400G		400G	800G	800G
400G-Q56DD-FR4		400G-Q56DD-EDR4 (Gen 3)	800G-O112-EDR8	800G-O112-2EDR4
400G-Q56DD-LR4		400G-Q56DD-LDR4		
100G				
100G-Q28-LR4 (Gen 4)				
100G-Q28-FR				
100G-Q28-LR				
40G				
40G-QSFP-LR4				
25G				
25G-SFP28-LR				
10G				
10G-SFP-LR				
Multimode				
100G	400G	400G	800G	800G
100G-Q28-SR1.2	400G-Q56DD-SR4.2-ON (Gen 3)	400G-Q112-VR4	800G-O112-VR8	800G-O112-2VR4
100G-Q28-BIDI	200G	400G-Q56DD-VR4	400G	
100G-Q28-SWDM4	200G-Q56-SR4		400G-Q56DD-SR8	
40G	100G			
40G-QSFP-BIDI	100G-Q28-ESR4			
40G-QSFP-SM4	100G-Q28-SR4			
25G	40G			
25G-SFP28-ESR	40G-QSFP-SR4			
25G-SFP28-SR				
10G				
10G-SFP-SR				
				

For the most updated DELL transceiver information please refer to "DELL Networking Transceivers and Cables" within <https://www.delltechnologies.com/>

2. Cabling Recommendations

The following Scenarios describe two main applications:

- **Point-to-Point Cabling**, which most of the time involves connecting a server to a leaf switch located within the same rack or row. In some cases, this type of cabling can also be used to connect different switches, such as Leaf to Spine. However, it is not recommended to use Point-to-Point cabling if these switches are physically located in different areas within the data center.
- **Structured Cabling**, which utilizes an optical fiber trunk as a backbone. This application is primarily used to connect different switches, such as Leaf to Spine, and can also be implemented to connect Spine to Core. It is the recommended option to follow when two different active devices are physically located in different areas within the data center.

Choosing between the two applications will depend on the specific data center design, and will be done case by case. For more information and design recommendations, please contact a Corning representative.

2.1. Scenario 1 – MPO-16 APC to MPO-16 APC Using Point-to-Point Cabling Server-to-Switch Applications



Figure 1. Use case for MPO-16 APC to MPO-16 APC using Point-to-Point Cabling.

Use case	Near End Optic (Left)		Far End Optic (Right)		Reach	Fiber Type
	Speed	Fiber/Transceiver	Speed	Fiber/Transceiver		
A	800G-O112-EDR8	1x 16F	800G-O112-EDR8	1x 16F	500 m	Single-mode
A	800G-O112-VR8	1x 16F	800G-O112-VR8	1x 16F	50 m	Multimode
	400G-Q56DD-SR8	1x 16F	400G-Q56DD-SR8	1x 16F	100 m	Multimode

Item	OS2 Part Number (Americas)	OS2 Part Number (EMEA and APJ)	OM4 Part Number (Americas)	OM4 Part Number (EMEA and APJ)	Description
1	JC6C616GPH-NBxxxF	JC6C616GEZ-NBxxXM	JC3C316QPH-NBxxxF	JC3C316QEZ-NBxxXM	16F Jumper, MTP [®] -16 APC (non-pinned) to MTP-16 APC (non-pinned), Type-B polarity, xxxF (feet) or xxxM (meters)

- Notes:**
- Corning cables in the Americas use Plenum cable, while EMEA/APJ uses LSZH™/CPR rated cable. Jumper lengths are available from 1 to 300 meters. Lengths in meters are also available for the Americas.
 - Please review Corning's polarity drawings in Annex 2.

2.2. Scenario 2 – MPO-16 APC to MPO-16 APC Using Structured Cabling Switch-to-Switch Applications

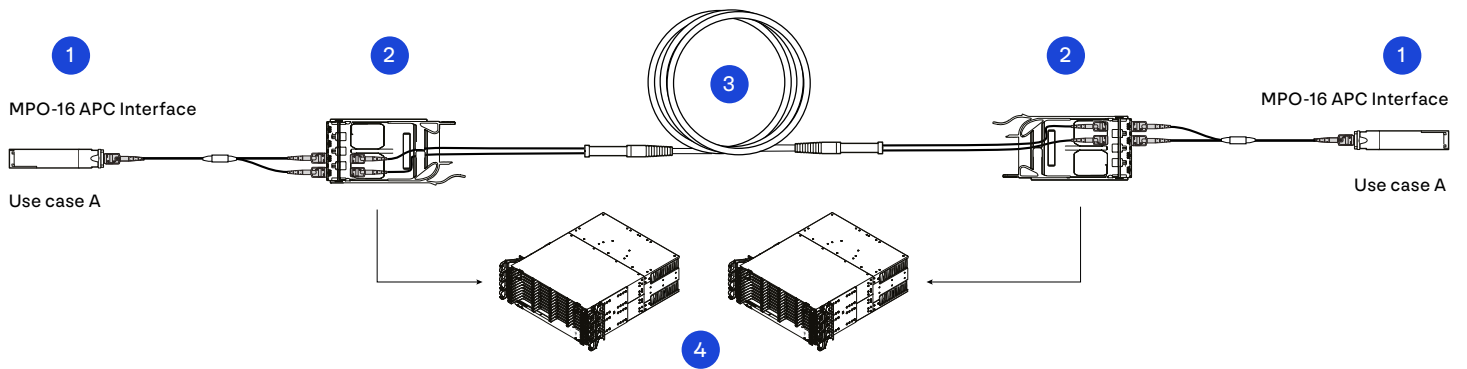

Figure 2. Use case for MPO-16 APC to MPO-16 APC using Structured Cabling.

Use case	Near End Optic (Left)		Far End Optic (Right)		Reach	Fiber Type
	Speed	Fiber/Transceiver	Speed	Fiber/Transceiver		
A	800G-O112-EDR8	1x 16F	800G-O112-EDR8	1x 16F	500 m	Single-mode
A	800G-O112-VR8	1x 16F	800G-O112-VR8	1x 16F	50 m	Multimode
	400G-Q56DD-SR8	1x 16F	400G-Q56DD-SR8	1x 16F	100 m	Multimode

Item	OS2 Part Number (Americas)	OS2 Part Number (EMEA and APJ)	OM4 Part Number (Americas)	OM4 Part Number (EMEA and APJ)	Description
1	HC6E816GPH-LBxxxF	HC6E816GLZ-LBxxxM	HC3E916QPH-LBxxxF	HC3E916QLZ-LBxxxM	16F Y-Harness, MTP®-16 APC (non-pinned) to two 8F MTP APC (non-pinned), 36-in (910 mm) breakout leg length, Type-B polarity, xxxF (feet) or xxxM (meters)
2	EDGE8-CP32-V1	EDGE8-CP32-V1	EDGE8-CP32-V3	EDGE8-CP32-V3	EDGE8® 32F MTP Adapter Panel, (4-port)
3	GE7E7E4GPNDUxxxF	GE7E7E4GLZDDUxxxM	GE2E2E4QPNDUxxxF	GE2E2E4QLZDDUxxxM	EDGE8 Trunk, 144F, MTP APC (pinned) to MTP APC (pinned), 33-in (840 mm) legs, Type-B polarity, pulling grip on first end only, xxxF (feet) or xxxM (meters)
4	EDGE8-xxU	EDGE8-xxU	EDGE8-xxU	EDGE8-xxU	Please refer to Annex 1 to choose the best option for your application

Notes:

- a) Corning cables in the Americas use Plenum cable, while EMEA/APJ uses LSZH™/CPR rated cable. Jumper lengths are available from 1 to 300 meters. Lengths in meters are also available for the Americas.
- b) Trunks are available in fiber counts of 8 to 288 fibers.
- c) Please review Corning's polarity drawings in Annex 2.

2.3. Scenario 3 – MPO-16 APC to MPO-12 APC Using Point-to-Point Cabling Server-to-Switch Applications

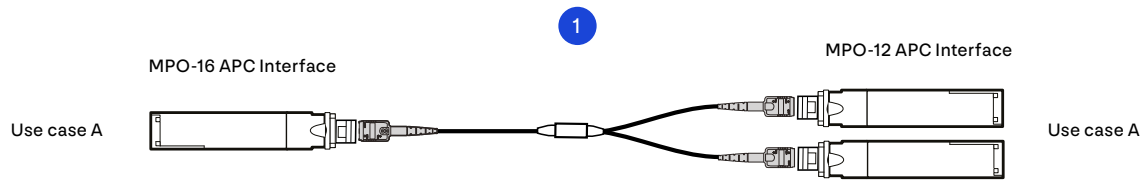

Figure 3. Use case for MPO-16 APC to MPO-12 APC using Point-to-Point Cabling.

Use case	Near End Optic (Left)		Far End Optic (Right)		Reach	Fiber Type
	Speed	Fiber/Transceiver	Speed	Fiber/Transceiver		
A	800G-O112-VR8	1x 16F	400G-Q56DD-VR4	8F	50 m	Multimode

Item	OM4 Part Number (Americas)	OM4 Part Number (EMEA and APJ)	Description
1	HC3E916QPH-LBxxxF	HC3E916QLZ-LBxxxM	16F Y-Harness, MTP®-16 APC (non-pinned) to two 8F MTP APC (non-pinned), 36-in (910 mm) breakout leg length, Type-B polarity, xxxF (feet) or xxxM (meters)

- Notes:**
- a) Corning cables in the Americas use Plenum cable, while EMEA/APJ uses LSZH™/CPR rated cable. Y-Harness lengths are available from 1 to 60 meters (measured from MTP-16 to furcation plug). Lengths in meters are also available for the Americas.
 - b) Please review Corning's polarity drawings in Annex 2.

2.4. Scenario 4 – MPO-16 APC to MPO-12 APC Using Structured Cabling Switch-to-Switch Applications

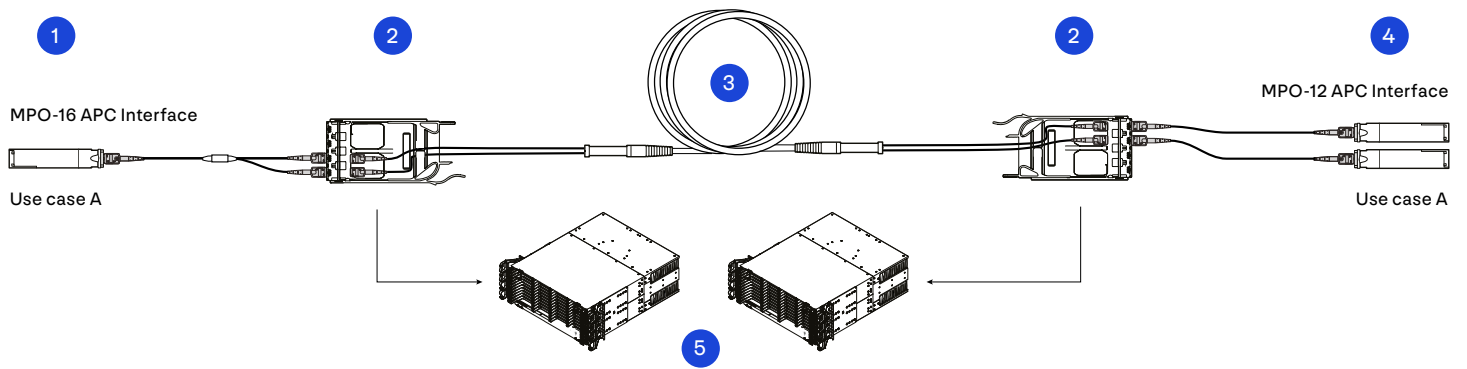

Figure 4. Use case for MPO-16 APC to MPO-12 APC using Structured Cabling.

Use case	Near End Optic (Left)		Far End Optic (Right)		Reach	Fiber Type
	Speed	Fiber/Transceiver	Speed	Fiber/Transceiver		
A	800G-O112-VR8	1x 16F	400G-Q56DD-VR4	8F	50 m	Multimode

Item	OM4 Part Number (Americas)	OM4 Part Number (EMEA and APJ)	Description
1	HC3E916QPH-LBxxxF	HC3E916QLZ-LBxxxM	16F Y-Harness, MTP [®] -16 APC (non-pinned) to two 8F MTP APC (non-pinned), 36-in (910 mm) breakout leg length, Type-B polarity, xxxF (feet) or xxxM (meters)
2	EDGE8-CP32-V3	EDGE8-CP32-V3	EDGE8 [®] 32F MTP Adapter Panel, (4-port)
3	GE2E2E4QPNDUxxxF	GE2E2E4QLZDDUxxxM	EDGE8 Trunk, 144F, MTP APC (pinned) to MTP APC (pinned), 33-in (840 mm) legs, Type-B polarity, pulling grip on first end only, xxxF (feet) or xxxM (meters)
4	JE9E908QE8-NBxxxF	JE9E908QE8-NBxxxM	EDGE8, 8F Jumper, MTP APC (unpinned) to MTP APC (unpinned), Type-B polarity, xxxF (feet) or xxxM (meters)
5	EDGE8-xxU	EDGE8-xxU	Please refer to Annex 1 to choose the best option for your application

- Notes:**
- a) Corning cables in the Americas use Plenum cable, while EMEA/APJ uses LSZH[™]/CPR rated cable. Y-Harness lengths are available from 1 to 60 meters (measured from MTP-16 to furcation plug). Jumper lengths are available from 1 to 300 meters. Lengths in meters are also available for the Americas.
 - b) Trunks are available in fiber counts of 8 to 288 fibers.
 - c) Please review Corning's polarity drawings in Annex 2.

2.5. Scenario 5 – MPO-16 APC to MPO-12 PC Using Point-to-Point Cabling Server-to-Switch Applications

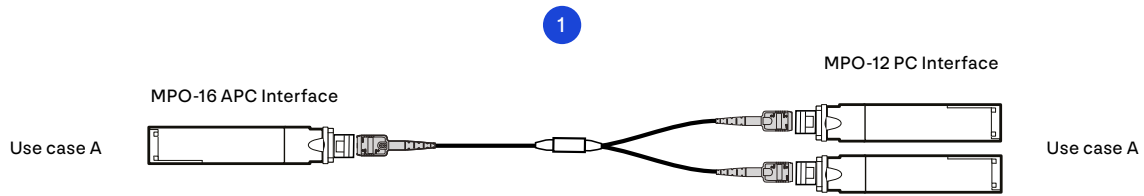

Figure 5. Use case for MPO-16 APC to MPO-12 PC using Point-to-Point Cabling.

Use case	Near End Optic (Left)		Far End Optic (Right)		Reach	Fiber Type
	Speed	Fiber/Transceiver	Speed	Fiber/Transceiver		
A	400G-Q56DD-SR8	1x 16F	200G-Q56-SR4	8F	100 m	Multimode

Item	OM4 Part Number (Americas)	OM4 Part Number (EMEA and APJ)	Description
1	HC3E616QPH-LBxxxF	HC3E616QLZ-LBxxXM	16F Y-Harness, MTP®-16 APC (non-pinned) to two 8F MTP PC (non-pinned), 36-in (910 mm) breakout leg length, Type-B polarity, xxxF (feet) or xxxM (meters)

- Notes:**
- a) Corning cables in the Americas use Plenum cable, while EMEA/APJ uses LSZH™/CPR rated cable. Y-Harness lengths are available from 1 to 60 meters (measured from MTP-16 to furcation plug). Lengths in meters are also available for the Americas.
 - b) Please review Corning's polarity drawings in Annex 2.

2.6. Scenario 6 – MPO-16 APC to MPO-12 PC Using Structured Cabling Switch-to-Switch Applications

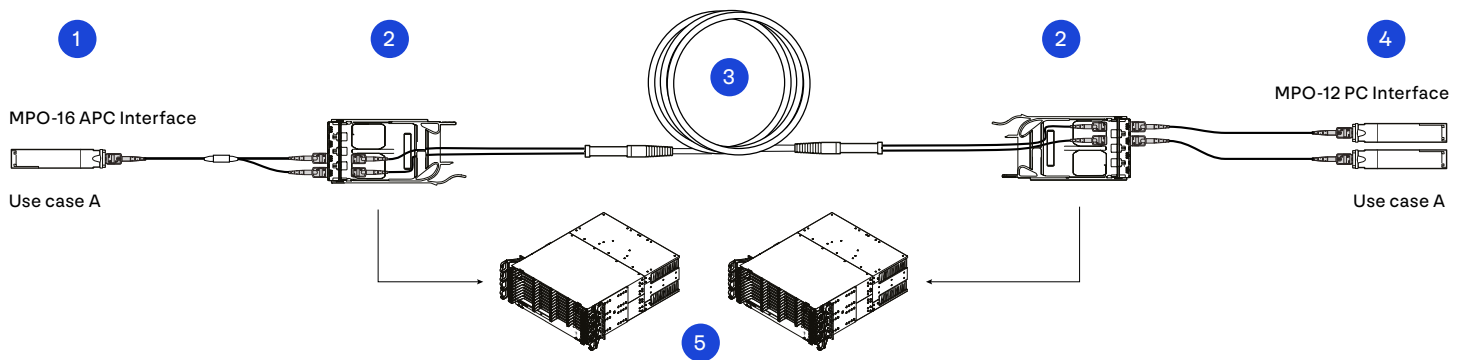

Figure 6. Use case for MPO-16 APC to MPO-12 PC using Structured Cabling.

Use case	Near End Optic (Left)		Far End Optic (Right)		Reach	Fiber Type
	Speed	Fiber/Transceiver	Speed	Fiber/Transceiver		
A	400G-Q56DD-SR8	1x 16F	200G-Q56-SR4	8F	100 m	Multimode

Item	OM4 Part Number (Americas)	OM4 Part Number (EMEA and APJ)	Description
1	HC3E616QPH-LBxxx F	HC3E616QLZ-LBxxx M	16F Y-Harness, MTP [®] -16 APC (non-pinned) to two 8F MTP PC (non-pinned), 36-in (910 mm) breakout leg length, Type-B polarity, xxx F (feet) or xxx M (meters)
2	EDGE8-CP32-V3	EDGE8-CP32-V3	EDGE8 [®] 32F MTP Adapter Panel, (4-port)
3	GE5E5E4QPNDDUxxx F	GE5E5E4QLZDDUxxx F	EDGE8 Trunk, 144F, MTP PC (pinned) to MTP PC (pinned), 33-in (840 mm) legs, Type-B polarity, pulling grip on first end only, xxx F (feet) or xxx M (meters)
4	JE6E608QE8-NBxxx F	JE6E608QE8-NBxxx M	EDGE8, MTP PC (non-pinned) to MTP PC (non-pinned) 8F Jumper, TIA-568 Type-B polarity, xxx F (feet) or xxx M (meters)
5	EDGE8-xxU	EDGE8-xxU	Please refer to Annex 1 to choose the best option for your application

- Notes:**
- a) Corning cables in the Americas use Plenum cable, while EMEA/APJ uses LSZH[™]/CPR rated cable. Y-Harness lengths are available from 1 to 60 meters (measured from MTP-16 to furcation plug). Jumper lengths are available from 1 to 300 meters. Lengths in meters are also available for the Americas.
 - b) Trunks are available in fiber counts of 8 to 288 fibers.
 - c) Please review Corning's polarity drawings in Annex 2.

2.7. Scenario 7 – MPO-12 APC to MPO-12 APC Using Point-to-Point Cabling Server-to-Switch Applications

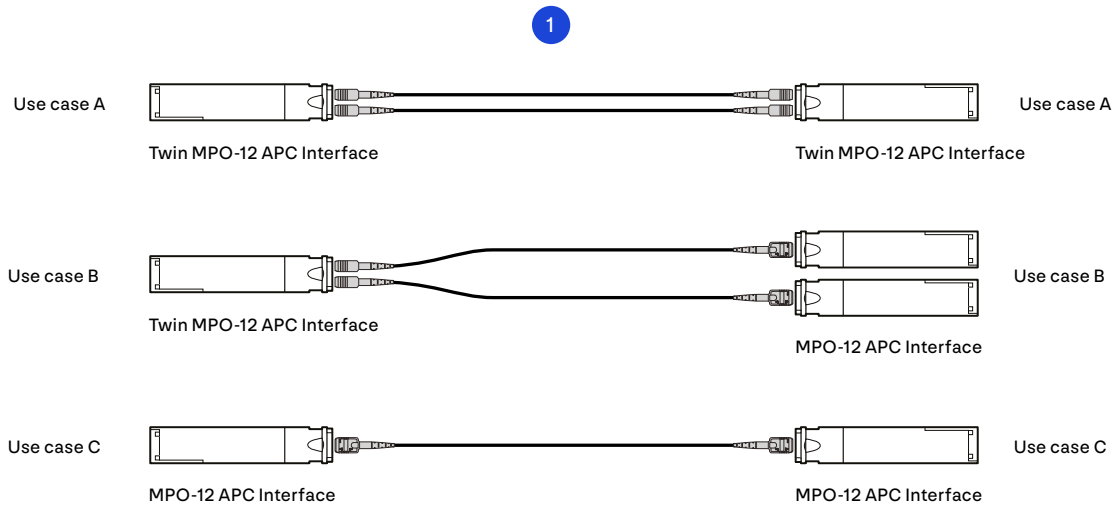

Figure 7. Use cases for MPO-12 APC to MPO-12 APC using Point-to-Point Cabling.

Use case	Near End Optic (Left)		Far End Optic (Right)		Reach	Fiber Type
	Speed	Fiber/Transceiver	Speed	Fiber/Transceiver		
A	800G-O112-2EDR4	2x 8F	800G-O112-2EDR4	2x 8F	2 km	Single-mode
B	800G-O112-2EDR4	2x 8F	400G-Q56DD-EDR4	8F	2 km	Single-mode
C	400G-Q56DD-EDR4 (Gen 3)	8F	400G-Q56DD-EDR4 (Gen 3)	8F	2 km	Single-mode
	400G-Q56DD-LDR4	8F	400G-Q56DD-LDR4	8F	10 km	Single-mode
A	800G-O112-2VR4	2x 8F	800G-O112-2VR4	2x 8F	50 m	Multimode
B	800G-O112-2VR4	2x 8F	400G-Q112-VR4	8F	50 m	Multimode
	800G-O112-2VR4	2x 8F	400G-Q56DD-VR4	8F	50 m	Multimode
C	400G-Q112-VR4	8F	400G-Q112-VR4	8F	50 m	Multimode
	400G-Q112-VR4	8F	400G-Q56DD-VR4	8F	50 m	Multimode
	400G-Q56DD-VR4	8F	400G-Q56DD-VR4	8F	50 m	Multimode
	400G-Q56DD-VR4	8F	400G-Q112-VR4	8F	50 m	Multimode

Item	OS2 Part Number (Americas)	OS2 Part Number (EMEA and APJ)	OM4 Part Number (Americas)	OM4 Part Number (EMEA and APJ)	Description
1	JE8E808GE8-NBxxxF	JE8E808GEZ-NBxxxM	JE9E908QE8-NBxxxF	JE9E908QEZ-NBxxxM	EDGE8 [®] , 8F Jumper, MTP [®] APC (non-pinned) to MTP APC (non-pinned), Type-B polarity, xxxF (feet) or xxxM (meters)
	or				
	G-BND64-E8E8G-PN000-xxxF	G-BND64-E8E8G-LZ000-xxxM	G-BND64-E9E9Q-PN000-xxxF	G-BND64-E9E9Q-LZ000-xxxM	64x 8F Mesh Bundle, MTP APC (non-pinned) to MTP APC (non-pinned), 78-in (2 m) legs, Type-B polarity, xxxF (feet) or xxxM (meters)

- Notes:**
- a) Corning cables in the Americas use Plenum cable, while EMEA/APJ uses LSZH[™]/CPR rated cable. Single jumper lengths are available from 1 to 300 meters. Bundled jumpers use a meshed sleeve. Bundled lengths are available from 10 to 300 meters (furcation-to-furcation) in increments of 5 meters. Bundles are available in 16, 32, 64 legs, and custom leg quantities with straight or staggered legs. Bundled jumpers up to 35 m long use OM3, while longer lengths utilize OM4. Lengths in meters are also available for the Americas.
- b) Please review Corning's polarity drawings in Annex 2.

2.8. Scenario 8 – MPO-12 APC to MPO-12 APC Using Structured Cabling Switch-to-Switch Applications

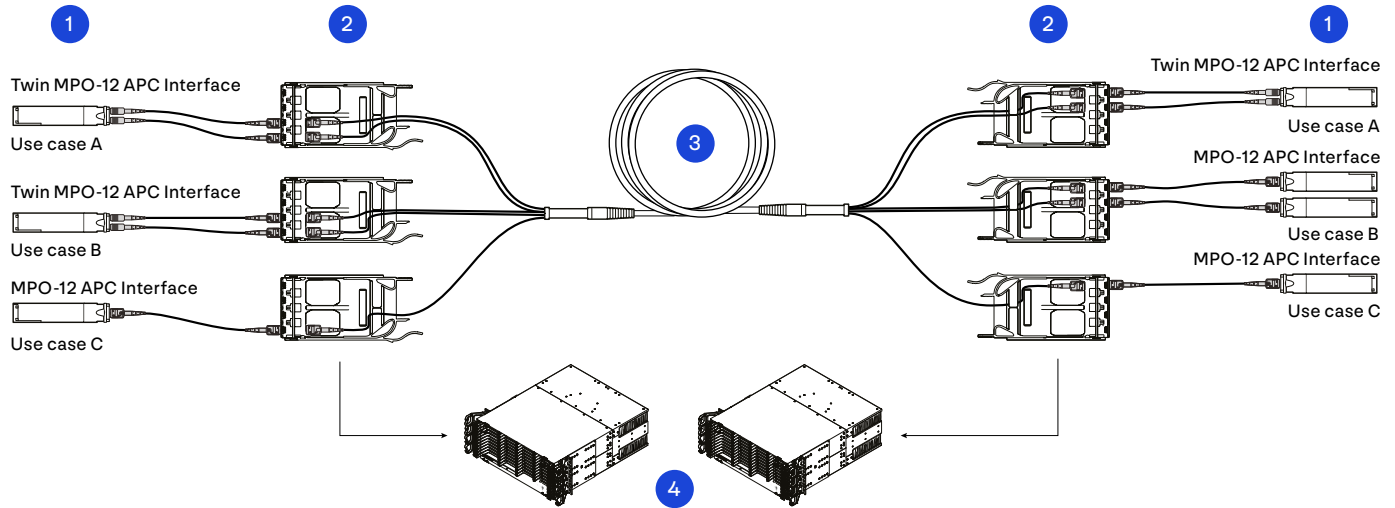

Figure 8. Use cases for MPO-12 APC to MPO-12 APC using Structured Cabling.

Use case	Near End Optic (Left)		Far End Optic (Right)		Reach	Fiber Type
	Speed	Fiber/Transceiver	Speed	Fiber/Transceiver		
A	800G-O112-2EDR4	2x 8F	800G-O112-2EDR4	2x 8F	2 km	Single-mode
B	800G-O112-2EDR4	2x 8F	400G-Q56DD-EDR4	8F	2 km	Single-mode
C	400G-Q56DD-EDR4 (Gen 3)	8F	400G-Q56DD-EDR4 (Gen 3)	8F	2 km	Single-mode
	400G-Q56DD-LDR4	8F	400G-Q56DD-LDR4	8F	10 km	Single-mode
A	800G-O112-2VR4	2x 8F	800G-O112-2VR4	2x 8F	50 m	Multimode
B	800G-O112-2VR4	2x 8F	400G-Q112-VR4	8F	50 m	Multimode
	800G-O112-2VR4	2x 8F	400G-Q56DD-VR4	8F	50 m	Multimode
C	400G-Q112-VR4	8F	400G-Q112-VR4	8F	50 m	Multimode
	400G-Q112-VR4	8F	400G-Q56DD-VR4	8F	50 m	Multimode
	400G-Q56DD-VR4	8F	400G-Q56DD-VR4	8F	50 m	Multimode
	400G-Q56DD-VR4	8F	400G-Q112-VR4	8F	50 m	Multimode

Item	OS2 Part Number (Americas)	OS2 Part Number (EMEA and APJ)	OM4 Part Number (Americas)	OM4 Part Number (EMEA and APJ)	Description
1	JE8E808GE8-NBxxxF	JE8E808GEZ-NBxxxM	JE9E908QE8-NBxxxF	JE9E908QEZ-NBxxxM	EDGE8®, 8F Jumper, MTP® APC (non-pinned) to MTP APC (non-pinned), Type-B polarity, xxxF (feet) or xxxM (meters)
	or				
	G-BND64-E8E8G-PN000-xxxF	G-BND64-E8E8G-LZ000-xxxM	G-BND64-E9E9Q-PN000-xxxF	G-BND64-E9E9Q-LZ000-xxxM	64x 8F Mesh Bundle, MTP APC (non-pinned) to MTP APC (non-pinned), 78-in (2 m) legs, Type-B polarity, xxxF (feet) or xxxM (meters)
2	EDGE8-CP32-V1	EDGE8-CP32-V1	EDGE8-CP32-V3	EDGE8-CP32-V3	EDGE8 32F MTP Adapter Panel, (4-port)
3	GE7E7E4GPNDU xxxF	GE7E7E4GLZDDU xxxM	GE2E2E4QPNDU xxxF	GE2E2E4QLZDDU xxxM	EDGE8 Trunk, 144F, MTP APC (pinned) to MTP APC (pinned), 33-in (840 mm) legs, Type-B polarity, pulling grip on first end only, xxxF (feet) or xxxM (meters)
4	EDGE8-xxU	EDGE8-xxU	EDGE8-xxU	EDGE8-xxU	Please refer to Annex 1 to choose the best option for your application

- Notes:**
- a) Corning cables in the Americas use Plenum cable, while EMEA/APJ uses LSZH™/CPR rated cable. Single jumper lengths are available from 1 to 300 meters. Bundled jumpers use a meshed sleeve. Bundled lengths are available from 10 to 300 meters (furcation-to-furcation) in increments of 5 meters. Bundles are available in 16, 32, 64 legs, and custom leg quantities with straight or staggered legs. Bundled jumpers up to 35 m long use OM3, while longer lengths utilize OM4. Lengths in meters are also available for the Americas.
 - b) Trunks are available in fiber counts of 8 to 288 fibers.
 - c) Please review Corning's polarity drawings in Annex 2.

2.9. Scenario 9 – MPO-12 APC to LC Duplex Using Point-to-Point Cabling Server-to-Switch Applications

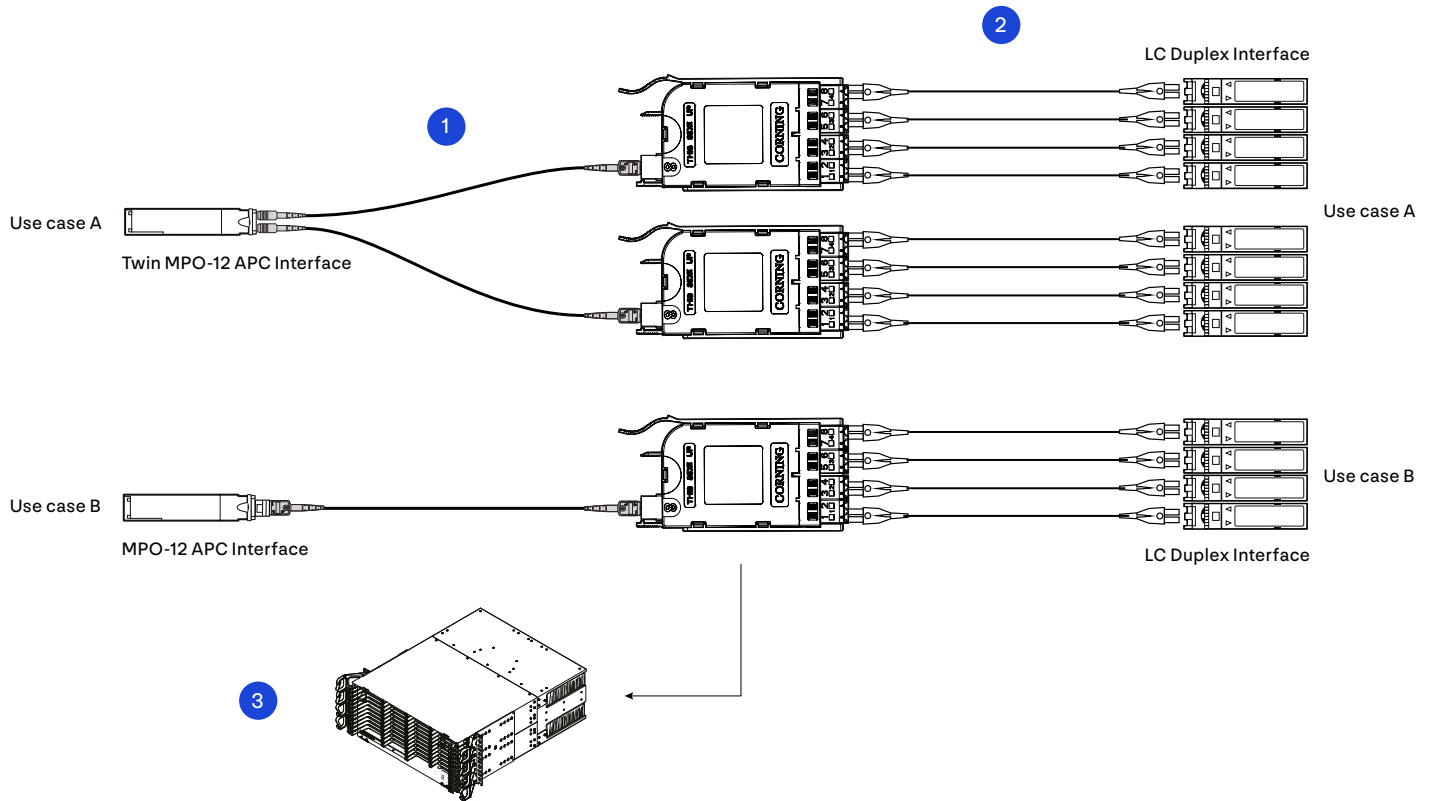

Figure 9. Use case for MPO-12 APC to LC Duplex using Point-to-Point Cabling.

Use case	Near End Optic (Left)		Far End Optic (Right)		Reach	Fiber Type
	Speed	Fiber/Transceiver	Speed	Fiber/Transceiver		
A	800G-O112-2EDR4	2x 8F	100G-Q28-FR	2F	2 km	Single-mode
B	400G-Q56DD-EDR4 (Gen 3)	8F	100G-Q28-FR	2F	2 km	Single-mode
	400G-Q56DD-EDR4 (Gen 3)	8F	100G-Q28-LR	2F	2 km	Single-mode
	400G-Q56DD-LDR4	8F	100G-Q28-LR	2F	2 km	Single-mode

Item	OS2 Part Number (Americas)	OS2 Part Number (EMEA and APJ)	Description
1	ECM8-04E8-GE8B-xxxF	ECM8-04E8-GEZB-xxxM	EDGE8® Port Breakout Module, LC Duplex UPC to MTP APC (non-pinned), 8F, Universal polarity, xxxF (feet) or xxxM (meters)
2	787802GD120xxxF	E787802GNZ20xxxM	EDGE™ LC Uniboot UPC to LC Uniboot UPC Jumper, 2.0 mm cable, xxxF (feet) or xxxM (meters)
3	EDGE8-xxU	EDGE8-xxU	Please refer to Annex 1 to choose the best option for your application

- Notes:**
- a) Corning cables in the Americas use Plenum cable, while EMEA/APJ uses LSZH™/CPR rated cable. Lengths in meters are also available for the Americas. Breakout modules have a maximum tail length of 25 meters (75 feet).
 - b) Please review Corning's polarity drawings in Annex 2.

2.10. Scenario 10 – MPO-12 APC to LC Duplex Using Structured Cabling Switch-to-Switch Applications

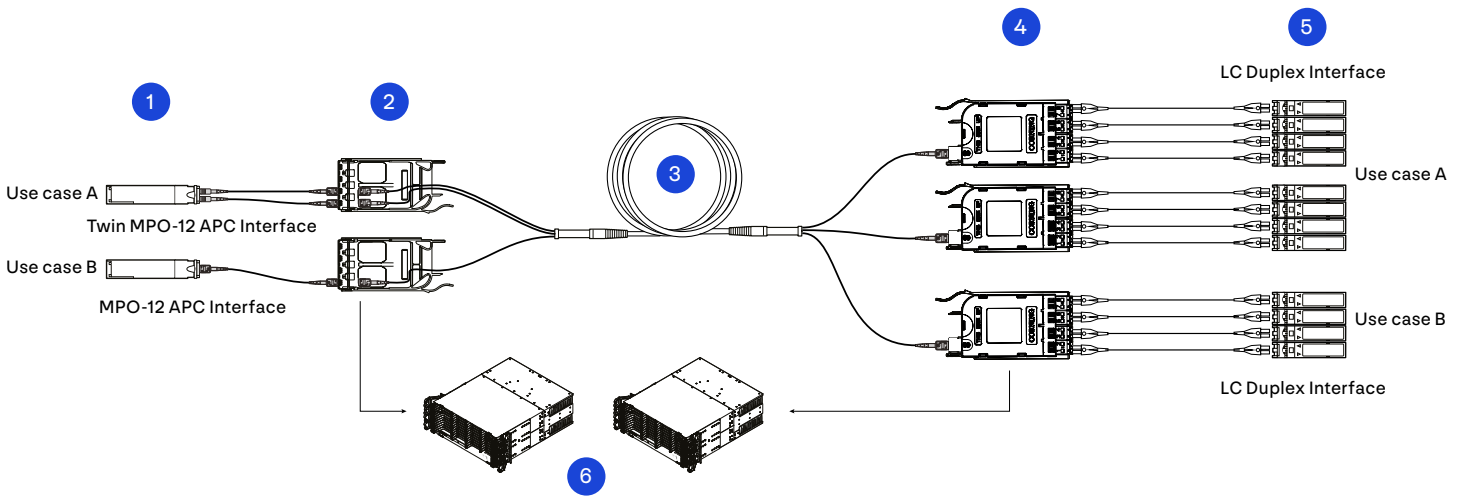

Figure 10. Use cases for MPO-12 APC to LC Duplex using Structured Cabling.

Use case	Near End Optic (Left)		Far End Optic (Right)		Reach	Fiber Type
	Speed	Fiber/Transceiver	Speed	Fiber/Transceiver		
A	800G-O112-2EDR4	2x 8F	100G-Q28-FR	2F	2 km	Single-mode
B	400G-Q56DD-EDR4 (Gen 3)	8F	100G-Q28-FR	2F	2 km	Single-mode
	400G-Q56DD-EDR4 (Gen 3)	8F	100G-Q28-LR	2F	2 km	Single-mode
	400G-Q56DD-LDR4	8F	100G-Q28-LR	2F	10 km	Single-mode

Item	OS2 Part Number (Americas)	OS2 Part Number (EMEA and APJ)	Description
1	JE8E808GE8-NAxxxF	JE8E808GEZ-NAxxxM	EDGE8®, 8F Jumper, MTP® APC (non-pinned) to MTP APC (non-pinned), Type-A polarity, xxxF (feet) or xxxM (meters)
2	EDGE8-CP32-V1	EDGE8-CP32-V1	EDGE8 32F MTP Adapter Panel, (4-port)
3	GE7E7E4GPNDUxxxF	GE7E7E4GLZDDUxxxM	EDGE8 Trunk, 144F, MTP APC (pinned) to MTP APC (pinned), 33-in (840 mm) legs, Type-B polarity, pulling grip on first end only, xxxF (feet) or xxxM (meters)
4	ECM8-UM08-04-E8G-ULL	ECM8-UM08-04-E8G-ULL	EDGE8 Ultra-Low-Loss Module, LC Duplex UPC to MTP (non-pinned), 8F, Universal polarity
5	787802GD120xxxF	E787802GNZ20xxxM	EDGE™ LC Uniboot UPC to LC Uniboot UPC Jumper, 2.0 mm cable, xxxF (feet) or xxxM (meters)
6	EDGE8-xxU	EDGE8-xxU	Please refer to Annex 1 to choose the best option for your application

Notes:

- a) Corning cables in the Americas use Plenum cable, while EMEA/APJ uses LSZH™/CPR rated cable. Single jumper lengths are available from 1 to 300 meters. Bundled jumpers use a meshed sleeve. Bundled lengths are available from 10 to 300 meters (furcation-to-furcation) in increments of 5 meters. Bundles are available in 16, 32, 64 legs, and custom leg quantities with straight or staggered legs. Lengths in meters are also available for the Americas.
- b) Trunks are available in fiber counts of 8 to 288 fibers.
- c) Please review Corning's polarity drawings in Annex 2.

2.11. Scenario 11 – MPO-12 PC to MPO-12 PC Using Point-to-Point Cabling Server-to-Switch Applications

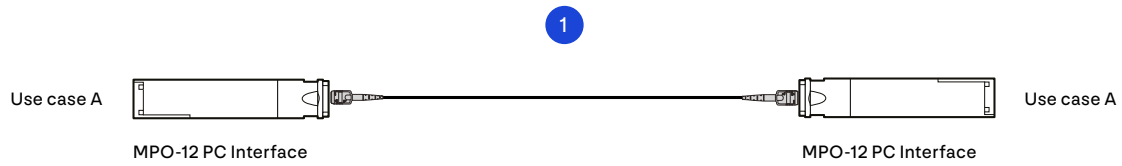

Figure 11. Use case for MPO-12 PC to MPO-12 PC using Structured Cabling.

Use case	Near End Optic (Left)		Far End Optic (Right)		Reach	Fiber Type
	Speed	Fiber/Transceiver	Speed	Fiber/Transceiver		
A	400G-Q56DD-SR4.2-ON (Gen 3)	8F	400G-Q56DD-SR4.2-ON (Gen 3)	8F	100 m	Multimode
	200G-Q56-SR4	8F	200G-Q56-SR4	8F	100 m	Multimode
	100G-Q28-SR4	8F	100G-Q28-SR4	8F	100 m	Multimode
	100G-Q28-ESR4	8F	100G-Q28-ESR4	8F	300 m	Multimode
	40G-QSFP-SR4	8F	40G-QSFP-SR4	8F	150 m	Multimode

Item	OM4 Part Number (Americas)	OM4 Part Number (EMEA and APJ)	Description
1	JE6E608QE8-NBxxxF	JE6E608QEZ-NBxxxM	EDGE8®, 8F Jumper, MTP® PC (non-pinned) to MTP PC (non-pinned), Type-B polarity, xxxF (feet) or xxxM (meters)

- Notes:**
- a) Corning cables in the Americas use Plenum cable, while EMEA/APJ uses LSZH™/CPR rated cable. Jumper lengths are available from 1 to 300 meters. Lengths in meters are also available for the Americas.
 - b) Please review Corning's polarity drawings in Annex 2.

2.12. Scenario 12 – MPO-12 PC to MPO-12 PC Using Structured Cabling Switch-to-Switch Applications

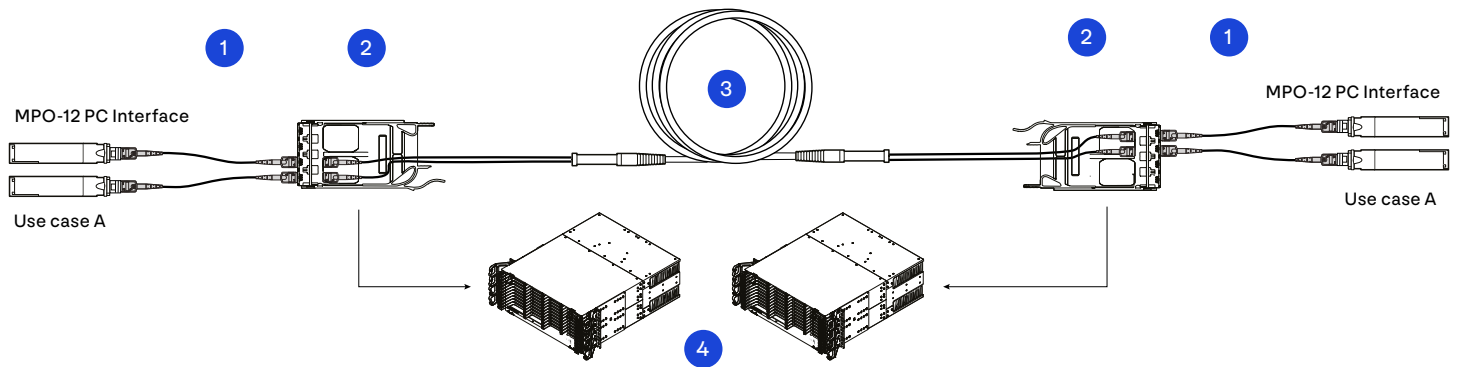

Figure 12. Use case for MPO-12 PC to MPO-12 PC using Structured Cabling.

Use case	Near End Optic (Left)		Far End Optic (Right)		Reach	Fiber Type
	Speed	Fiber/Transceiver	Speed	Fiber/Transceiver		
A	400G-Q56DD-SR4.2-ON (Gen 3)	8F	400G-Q56DD-SR4.2-ON (Gen 3)	8F	100 m	Multimode
	200G-Q56-SR4	8F	200G-Q56-SR4	8F	100 m	Multimode
	100G-Q28-SR4	8F	100G-Q28-SR4	8F	100 m	Multimode
	100G-Q28-ESR4	8F	100G-Q28-ESR4	8F	300 m	Multimode
	40G-QSFP-SR4	8F	40G-QSFP-SR4	8F	150 m	Multimode

Item	OM4 Part Number (Americas)	OM4 Part Number (EMEA and APJ)	Description
1	JE6E608QE8-NBxxxF	JE6E608QEZ-NBxxXM	EDGE8®, MTP® PC (non-pinned) to MTP PC (non-pinned) 8F Jumper, TIA-568 Type-B polarity, xxxF (feet) or xxxM (meters)
2	EDGE8-CP32-V3	EDGE8-CP32-V3	EDGE8 32F MTP Adapter Panel, (4-port)
3	GE5E5E4QPNDUxxxF	GE5E5E4QLZDDUxxXM	EDGE8 Trunk, 144F, MTP PC (pinned) to MTP PC (pinned), 33-in (840 mm) legs, Type-B polarity, pulling grip on first end only, xxxF (feet) or xxxM (meters)
4	EDGE8-xxU	EDGE8-xxU	Please refer to Annex 1 to choose the best option for your application

Notes:

- Corning cables in the Americas use Plenum cable, while EMEA/APJ uses LSZH™/CPR rated cable. Jumper lengths are available from 1 to 300 meters. Lengths in meters are also available for the Americas.
- Trunks are available in fiber counts of 8 to 288 fibers.
- Please review Corning's polarity drawings in Annex 2.

2.13. Scenario 13 – MPO-12 PC to LC Duplex Using Point-to-Point Cabling Server-to-Switch Applications

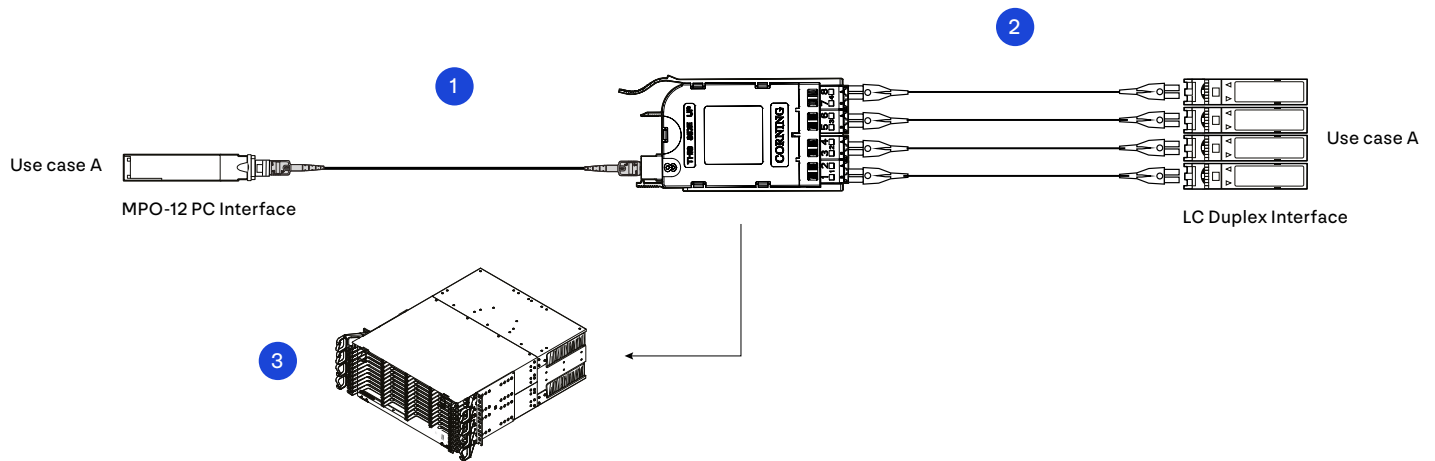

Figure 13. Use case for MPO-12 PC to LC Duplex using Point-to-Point Cabling.

Use case	Near End Optic (Left)		Far End Optic (Right)		Reach	Fiber Type
	Speed	Fiber/Transceiver	Speed	Fiber/Transceiver		
A	400G-Q56DD-SR4.2-ON (Gen 3)	8F	100G-Q28-SR1.2	2F	100 m	Multimode
	100G-Q28-SR4	8F	25G-SFP28-SR	2F	100 m	Multimode
	100G-Q28-ESR4	8F	25G-SFP28-ESR	2F	300 m	Multimode
	40G-QSFP-SR4	8F	10G-SFP-SR	2F	150 m	Multimode

Item	OM4 Part Number (Americas)	OM4 Part Number (EMEA and APJ)	Description
1	ECM8-05E6-QE8B-xxxF	ECM8-05E6-QEZB-xxxM	EDGE8® Port Breakout Module, LC Duplex UPC to MTP® PC (non-pinned), 8F, Universal polarity, xxxF (feet) or xxxM (meters)
2	787802GD120xxxF	E787802GNZ20xxxM	EDGE™ LC Uniboot UPC to LC Uniboot UPC Jumper, 2.0 mm cable, xxxF (feet) or xxxM (meters)
3	EDGE8-xxU	EDGE8-xxU	Please refer to Annex 1 to choose the best option for your application

- Notes:**
- a) Corning cables in the Americas use Plenum cable, while EMEA/APJ uses LSZH™/CPR rated cable. Lengths in meters are also available for the Americas. Breakout modules have a maximum tail length of 25 meters (75 feet).
 - b) Please review Corning's polarity drawings in Annex 2.

2.14. Scenario 14 – MPO-12 PC to LC Duplex Using Structured Cabling Switch-to-Switch Applications

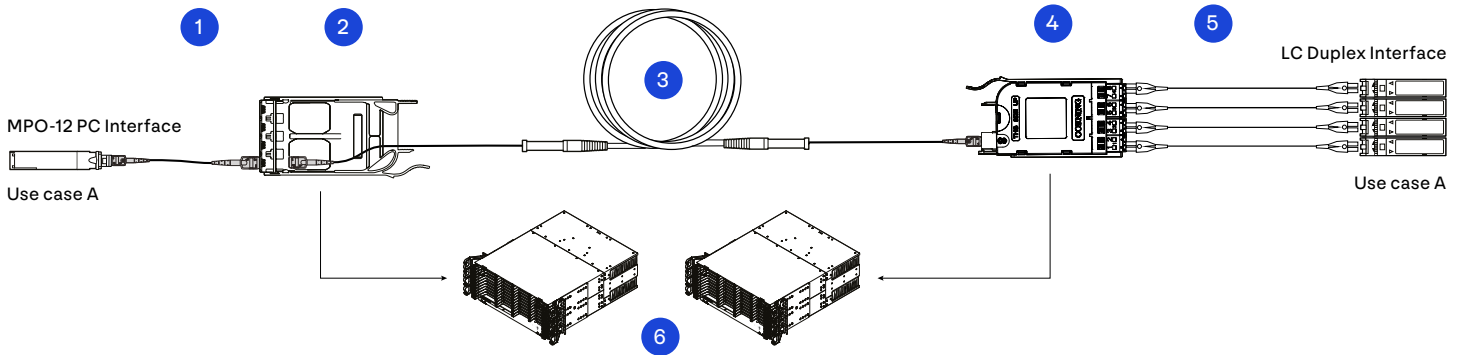

Figure 14. Use case for MPO-12 PC to LC Duplex using Structured Cabling.

Use case	Near End Optic (Left)		Far End Optic (Right)		Reach	Fiber Type
	Speed	Fiber/Transceiver	Speed	Fiber/Transceiver		
A	400G-Q56DD-SR4.2-ON (Gen 3)	8F	100G-Q28-SR1.2	2F	100 m	Multimode
	100G-Q28-SR4	8F	25G-SFP28-SR	2F	100 m	Multimode
	100G-Q28-ESR4	8F	25G-SFP28-ESR	2F	300 m	Multimode
	40G-QSFP-SR4	8F	10G-SFP-SR	2F	150 m	Multimode

Item	OM4 Part Number (Americas)	OM4 Part Number (EMEA and APJ)	Description
1	JE6E608QE8-NAxxxF	JE6E608QEZ-NAxxxM	EDGE8®, MTP® PC (non-pinned) to MTP PC (non-pinned) 8F Jumper, TIA-568 Type-A polarity, xxxF (feet) or xxxM (meters)
2	EDGE8-CP32-V3	EDGE8-CP32-V3	EDGE8 32F MTP Adapter Panel, (4-port)
3	GE5E5E4QPNDUxxxF	GE5E5E4QLZDDUxxxM	EDGE8 Trunk, 144F, MTP PC (pinned) to MTP PC (pinned), 33-in (840 mm) legs, Type-B polarity, pulling grip on first end only, xxxF (feet) or xxxM (meters)
4	ECM8-UM08-05-E6Q-ULL	ECM8-UM08-05-E6Q-ULL	EDGE8 Ultra-Low-Loss Module, LC Duplex UPC to MTP PC (non-pinned), 8F, Universal polarity
5	787802GD120xxxF	E787802GNZ20xxxM	EDGE™ LC Uniboot UPC to LC Uniboot UPC Jumper, 2.0 mm cable, xxxF (feet) or xxxM (meters)
6	EDGE8-xxU	EDGE8-xxU	Please refer to Annex 1 to choose the best option for your application

Notes:

- a) Corning cables in the Americas use Plenum cable, while EMEA/APJ uses LSZH™/CPR rated cable. Lengths in meters are also available for the Americas.
- b) Trunks are available in fiber counts of 8 to 288 fibers.
- c) Please review Corning's polarity drawings in Annex 2.

2.15. Scenario 15 – LC Duplex to LC Duplex Using Point-to-Point Cabling Server-to-Switch Applications

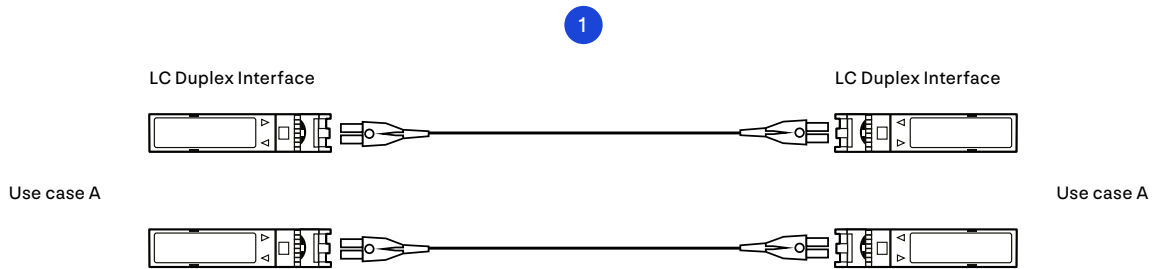

Figure 15. Use case for LC Duplex to LC Duplex using Point-to-Point Cabling.

Use case	Near End Optic (Left)		Far End Optic (Right)		Reach	Fiber Type
	Speed	Fiber/Transceiver	Speed	Fiber/Transceiver		
A	400G-Q56DD-FR4	2F	400G-Q56DD-FR4	2F	2 km	Single-mode
	400G-Q56DD-LR4	2F	400G-Q56DD-LR4	2F	10 km	Single-mode
	100G-Q28-LR4 (Gen 4)	2F	100G-Q28-LR4 (Gen 4)	2F	10 km	Single-mode
	100G-Q28-FR	2F	100G-Q28-FR	2F	2 km	Single-mode
	100G-Q28-LR	2F	100G-Q28-LR	2F	10 km	Single-mode
	40G-QSFP-LR4	2F	40G-QSFP-LR4	2F	10 km	Single-mode
	25G-SFP28-LR	2F	25G-SFP28-LR	2F	10 km	Single-mode
	10G-SFP-LR	2F	10G-SFP-LR	2F	10 km	Single-mode
A	100G-Q28-SR1.2	2F	100G-Q28-SR1.2	2F	100 m	Multimode
	100G-Q28-BIDI	2F	100G-Q28-BIDI	2F	100 m	Multimode
	100G-Q28-SWDM4	2F	100G-Q28-SWDM4	2F	100 m	Multimode
	40G-QSFP-BIDI	2F	40G-QSFP-BIDI	2F	150 m	Multimode
	40G-QSFP-SM4	2F	40G-QSFP-SM4	2F	250 m	Multimode
	25G-SFP28-ESR	2F	25G-SFP28-ESR	2F	300 m	Multimode
	25G-SFP28-SR	2F	25G-SFP28-SR	2F	100 m	Multimode
	10G-SFP-SR	2F	10G-SFP-SR	2F	400 m	Multimode

Item	OS2 Part Number (Americas)	OS2 Part Number (EMEA and APJ)	OM4 Part Number (Americas)	OM4 Part Number (EMEA and APJ)	Description
1	787802GD120xxxF	E787802GNZ20xxxM	797902QD120xxxF	E797902QNZ20xxxM	EDGE™ LC Uniboot UPC to LC Uniboot UPC Jumper, 2.0 mm cable, xxxF (feet) or xxxM (meters)

Notes:

- a) Corning cables in the Americas use Plenum cable, while EMEA/APJ uses LSZH™/CPR rated cable. Lengths in meters are also available for the Americas.
- b) Please review Corning's polarity drawings in Annex 2.

2.16. Scenario 16 – LC Duplex to LC Duplex Using Structured Cabling Switch-to-Switch Applications

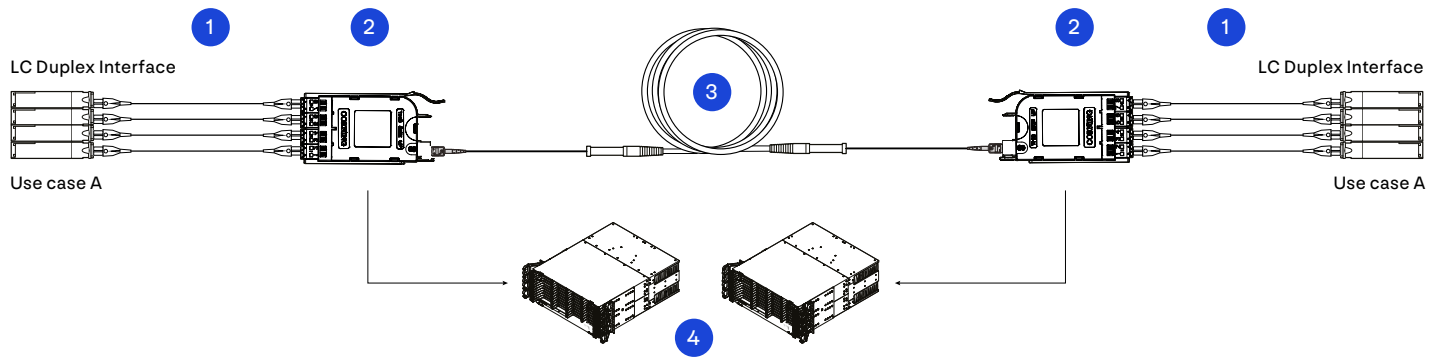

Figure 16. Use case for LC Duplex to LC Duplex using Structured Cabling.

Use case	Near End Optic (Left)		Far End Optic (Right)		Reach	Fiber Type
	Speed	Fiber/Transceiver	Speed	Fiber/Transceiver		
A	400G-Q56DD-FR4	2F	400G-Q56DD-FR4	2F	2 km	Single-mode
	400G-Q56DD-LR4	2F	400G-Q56DD-LR4	2F	10 km	Single-mode
	100G-Q28-LR4 (Gen 4)	2F	100G-Q28-LR4 (Gen 4)	2F	10 km	Single-mode
	100G-Q28-FR	2F	100G-Q28-FR	2F	2 km	Single-mode
	100G-Q28-LR	2F	100G-Q28-LR	2F	10 km	Single-mode
	40G-QSFP-LR4	2F	40G-QSFP-LR4	2F	10 km	Single-mode
	25G-SFP28-LR	2F	25G-SFP28-LR	2F	10 km	Single-mode
	10G-SFP-LR	2F	10G-SFP-LR	2F	10 km	Single-mode
A	100G-Q28-SR1.2	2F	100G-Q28-SR1.2	2F	100 m	Multimode
	100G-Q28-BIDI	2F	100G-Q28-BIDI	2F	100 m	Multimode
	100G-Q28-SWDM4	2F	100G-Q28-SWDM4	2F	100 m	Multimode
	40G-QSFP-BIDI	2F	40G-QSFP-BIDI	2F	150 m	Multimode
	40G-QSFP-SM4	2F	40G-QSFP-SM4	2F	250 m	Multimode
	25G-SFP28-ESR	2F	25G-SFP28-ESR	2F	300 m	Multimode
	25G-SFP28-SR	2F	25G-SFP28-SR	2F	100 m	Multimode
	10G-SFP-SR	2F	10G-SFP-SR	2F	400 m	Multimode

Item	OS2 Part Number (Americas)	OS2 Part Number (EMEA and APJ)	OM4 Part Number (Americas)	OM4 Part Number (EMEA and APJ)	Description
1	787802GD120xxxF	E787802GNZ20xxxM	797902QD120xxxF	E797902QNZ20xxxM	EDGE™ LC Uniboot UPC to LC Uniboot UPC Jumper, 2.0 mm cable, xxxF (feet) or xxxM (meters)
2	ECM8-UM08-04-E8G-ULL	ECM8-UM08-04-E8G-ULL	ECM8-UM08-05-E6Q-ULL	ECM8-UM08-05-E6Q-ULL	EDGE8® Ultra-Low-Loss Module, LC UPC/PC Duplex to MTP® APC/PC (non-pinned), 8F, Universal polarity
3	GE7E7E4GPNDU xxxF	GE7E7E4GLZDU xxxM	GE2E2E4QPNDU xxxF	GE2E2E4QLZDU xxxM	EDGE8 Trunk, 144F, MTP APC/PC (pinned) to MTP APC/PC (pinned), 33-in (840 mm) legs, Type-B polarity, pulling grip on first end only, xxxF (feet) or xxxM (meters)
4	EDGE8-xxU	EDGE8-xxU	EDGE8-xxU	EDGE8-xxU	Please refer to Annex 1 to choose the best option for your application



Notes:

- a) Corning cables in the Americas use Plenum cable, while EMEA/APJ uses LSZH™/CPR rated cable. Lengths in meters are also available for the Americas.
- b) Trunks in SMF use MTP-12 APC, while MMF use MTP-12 PC. Trunks are available in fiber counts of 8 to 288 fibers.
- c) Please review Corning's polarity drawings in Annex 2.

Annex 1 – High-Density Housings

EDGE8® HD housings mount in 19-inch racks or cabinets and provide industry-leading ultra-high-density connectivity when combined with EDGE8 modules, panels, harnesses, trunks, and jumpers.

As each customer and project has specific needs, please add the housing that best suits your needs to the BOM:

	Part Number (Global)	Maximum Number of Modules or Panels	Maximum Fiber Density		Height
	EDGE8-01U-SP	18	LC	144 fibers	1U
			MTP®	576 fibers	
	EDGE8-02U	36	LC	288 fibers	2U
			MTP	1,152 fibers	
	EDGE8-04U	72	LC	576 fibers	4U
			MTP	2,304 fibers	

Annex 2 – Polarity Drawings

Polarity drawings, often referred to as fiber optic polarity diagrams, are essential when designing and implementing data center links using fiber optic cabling. They play a crucial role in ensuring proper connectivity, signal integrity, and compatibility between different network components.

This section will cover the specific polarity drawings applicable to each one of the scenarios previously described.

Scenario 1 – MPO-16 APC to MPO-16 APC Using Point-to-Point Cabling

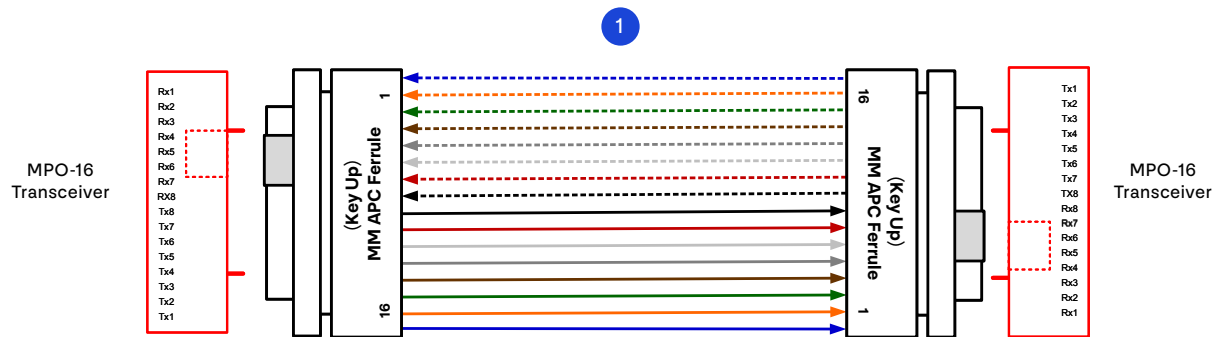

Scenario 2 – MPO-16 APC to MPO-16 APC Using Structured Cabling

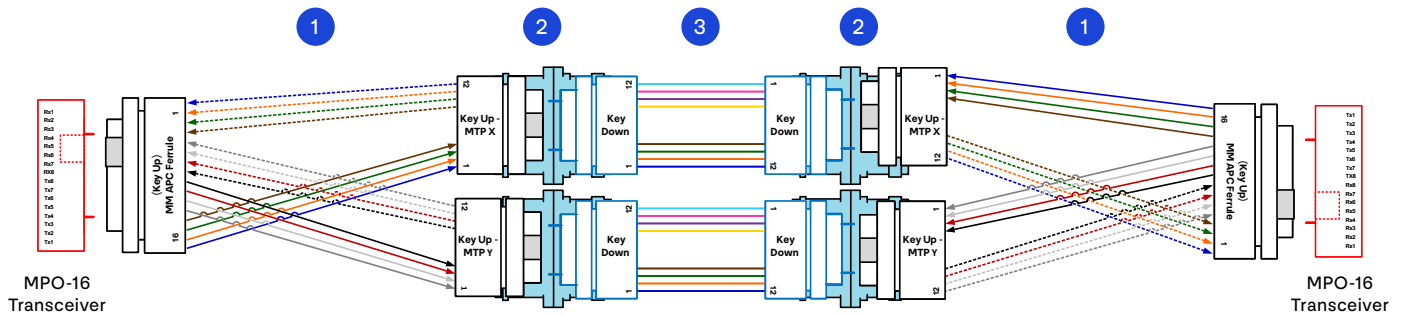

Scenario 3 – MPO-16 APC to MPO-12 APC Using Point-to-Point Cabling

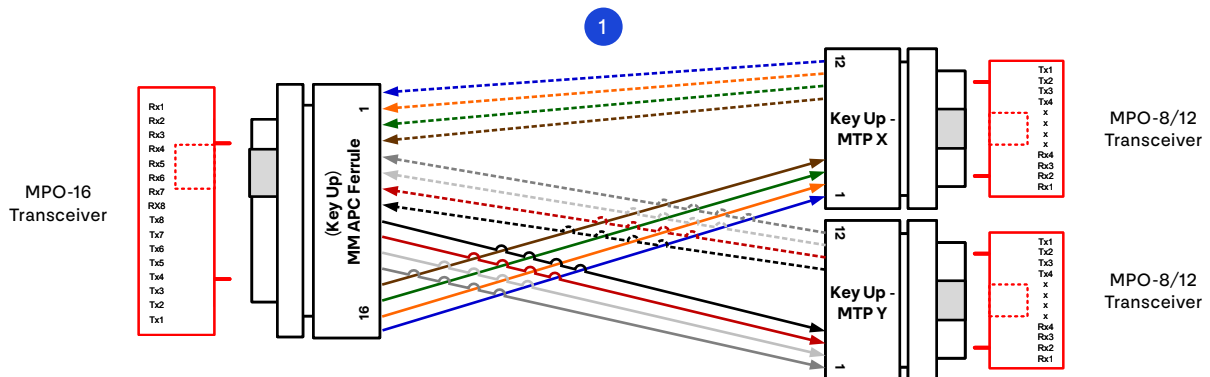

Scenario 4 – MPO-16 APC to MPO-12 APC Using Structured Cabling

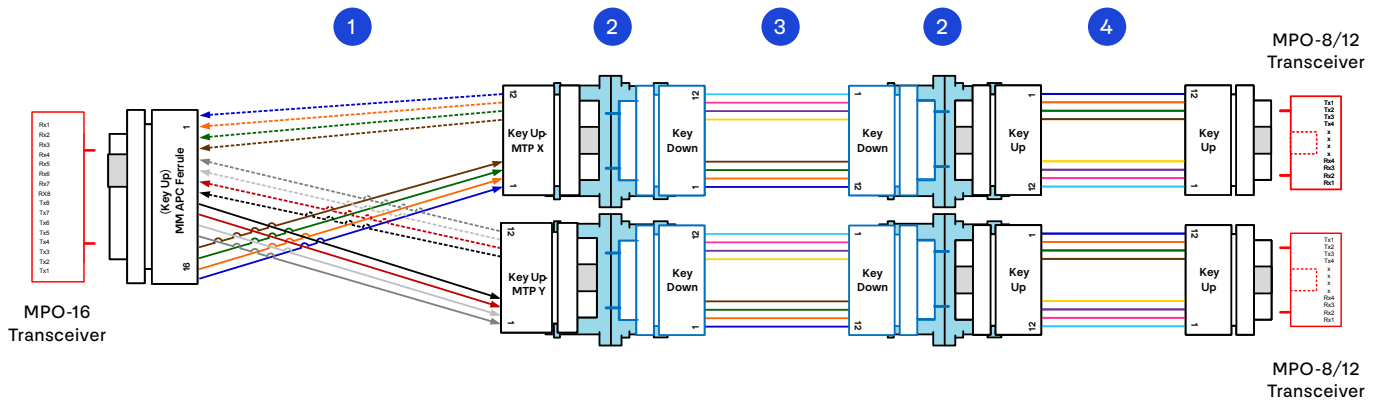

Scenario 5 – MPO-16 APC to MPO-12 PC Using Point-to-Point Cabling

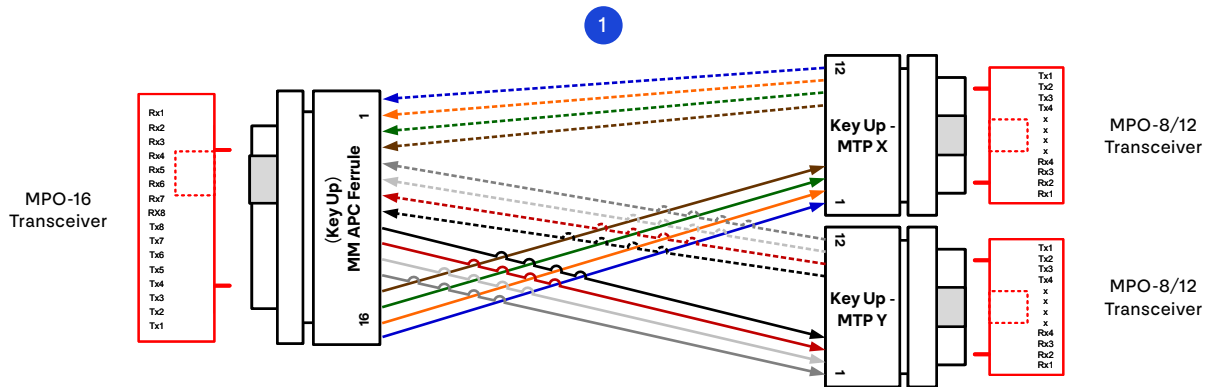

Scenario 6 – MPO-16 APC to MPO-12 PC Using Structured Cabling

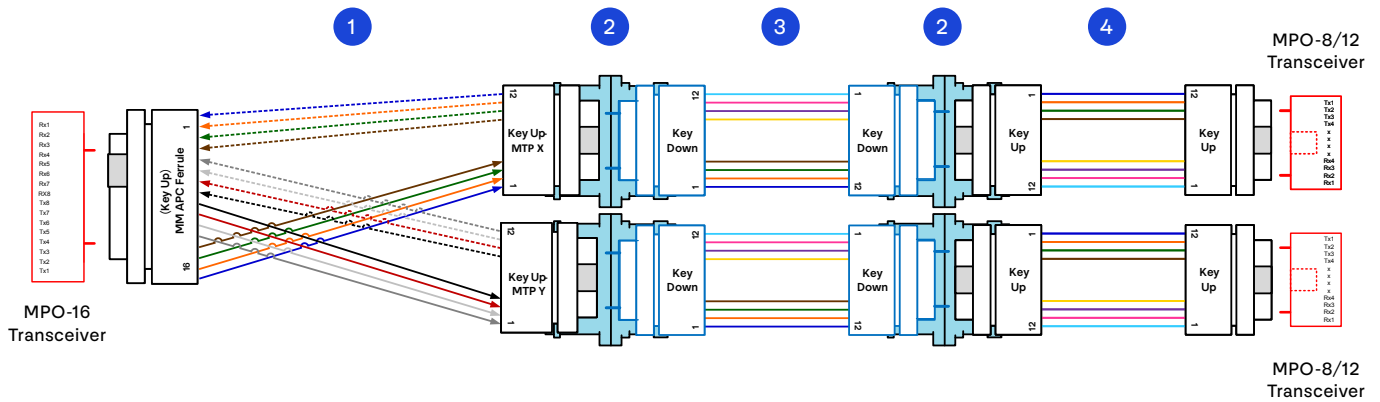

Scenario 7 – MPO-12 APC to MPO-12 APC Using Point-to-Point Cabling

Use Case A

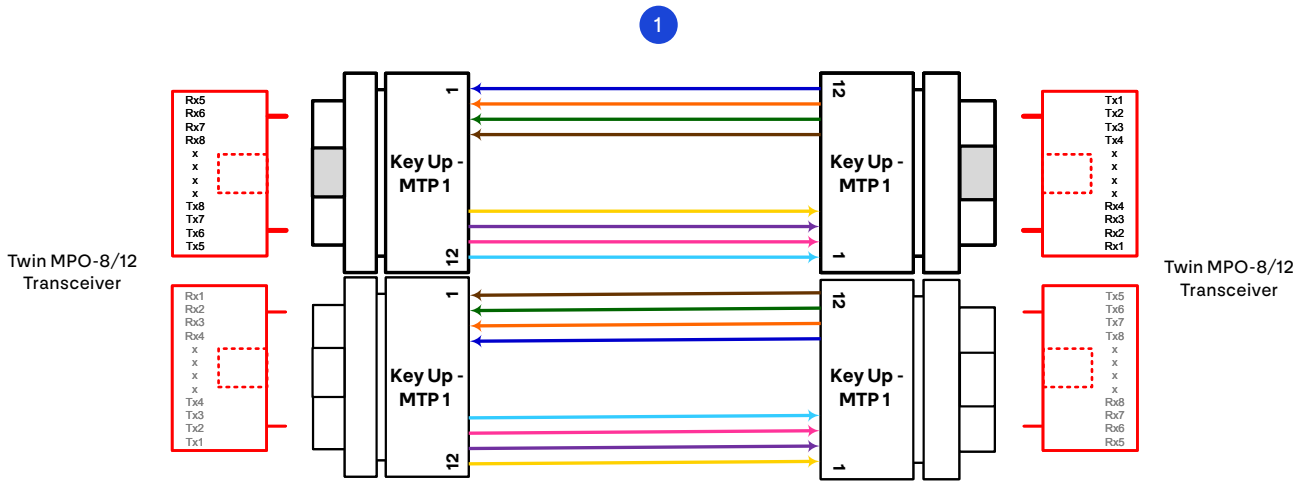

Use Case B

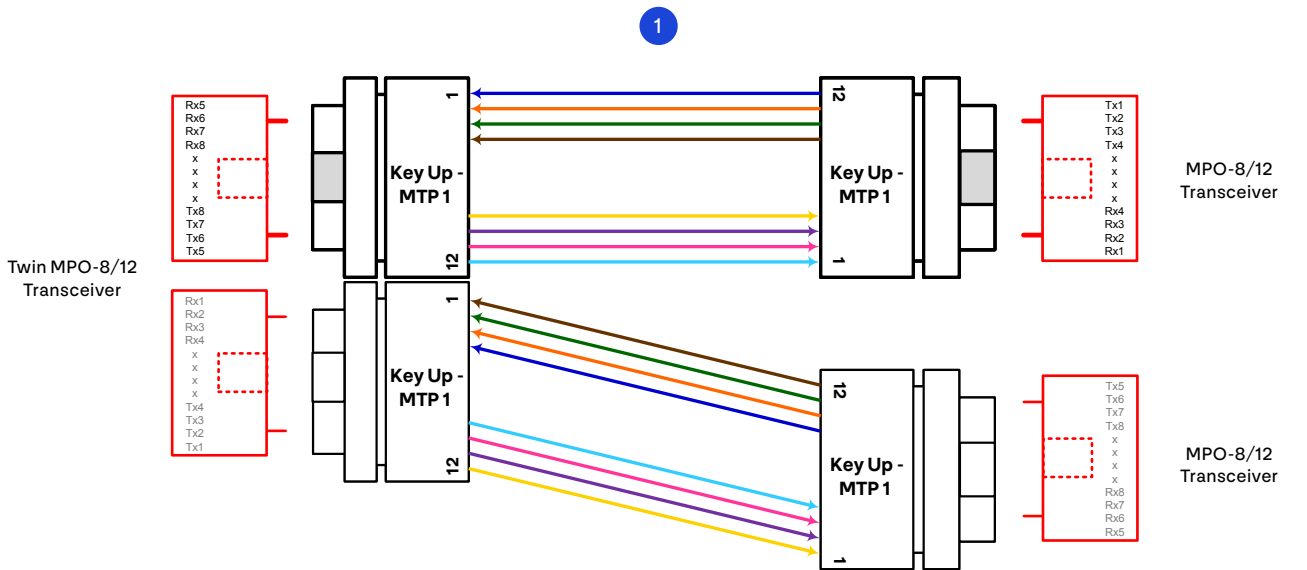

Use Case C

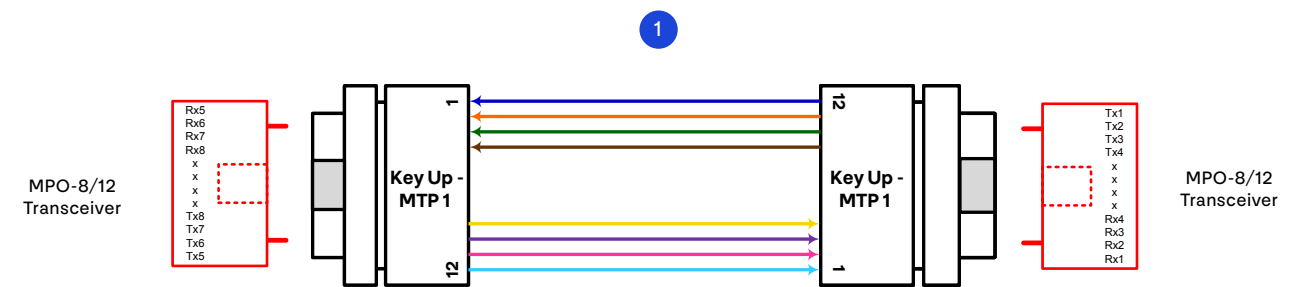

Scenario 8 – MPO-12 APC to MPO-12 APC Using Structured Cabling

Use Case A

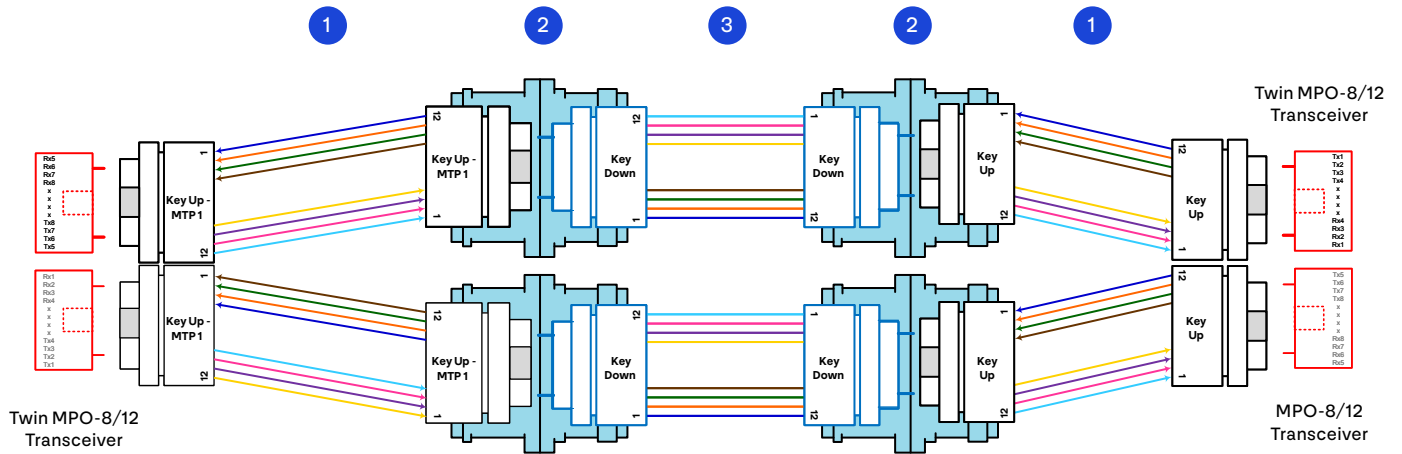

Use Case B

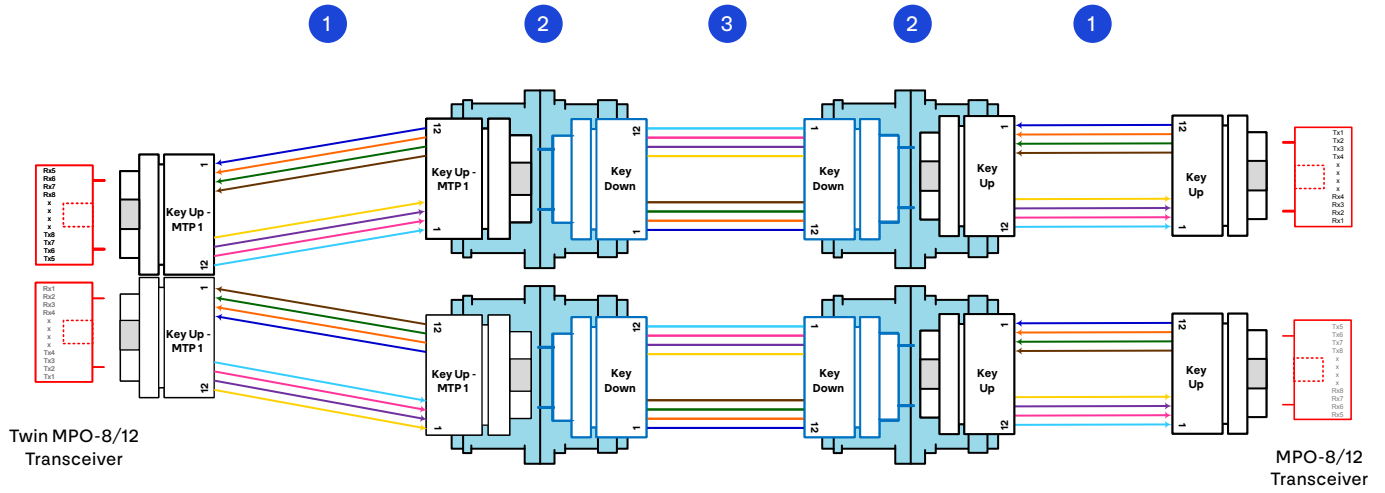

Use Case C

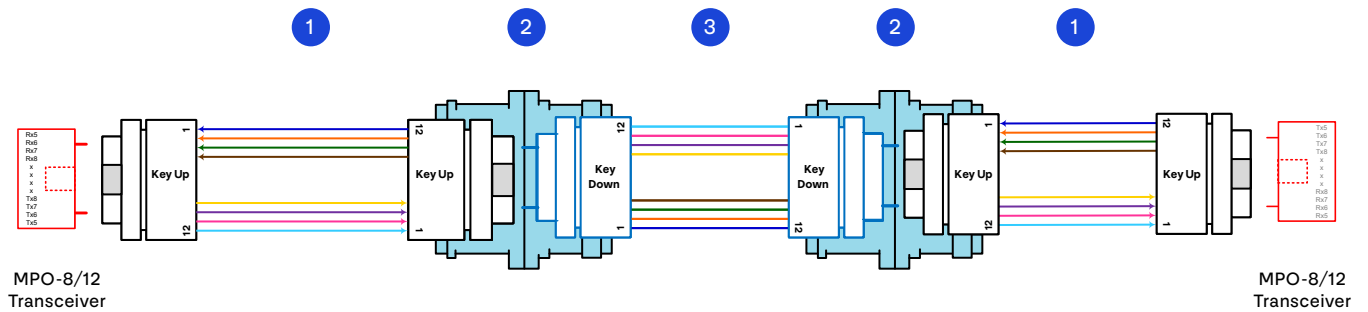

Scenario 9 – MPO-12 APC to LC Duplex Using Point-to-Point Cabling

Use Case A

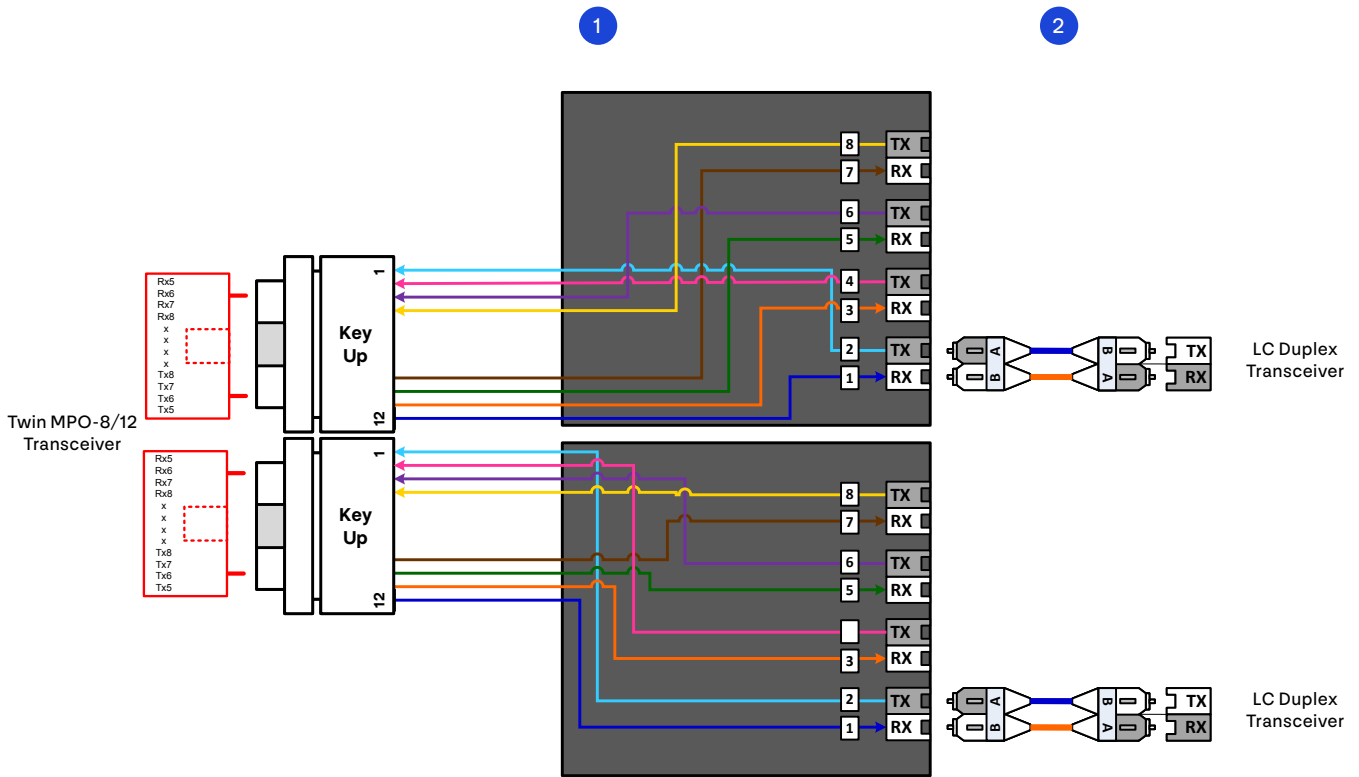

Use Case B

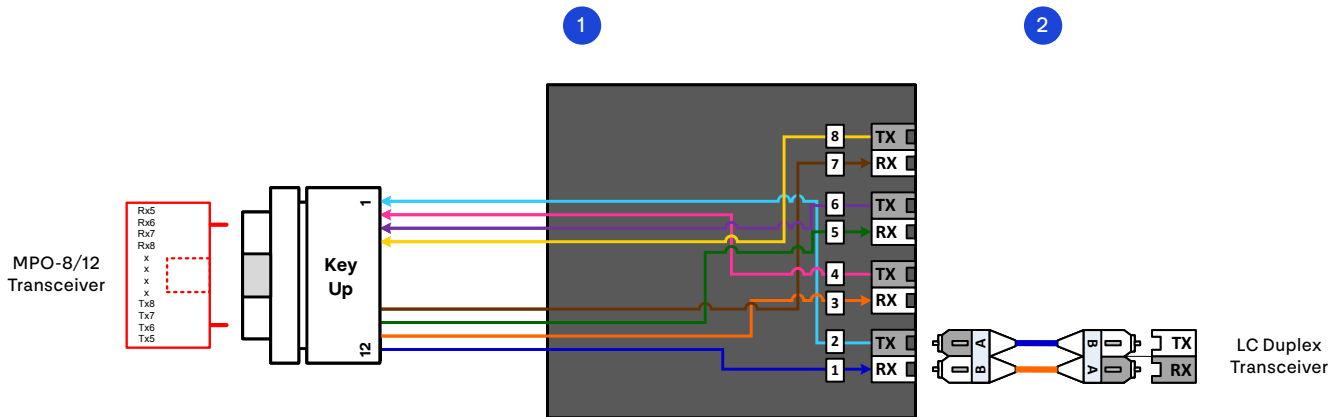

Scenario 10 – MPO-12 APC to LC Duplex Using Structured Cabling

Use Case A

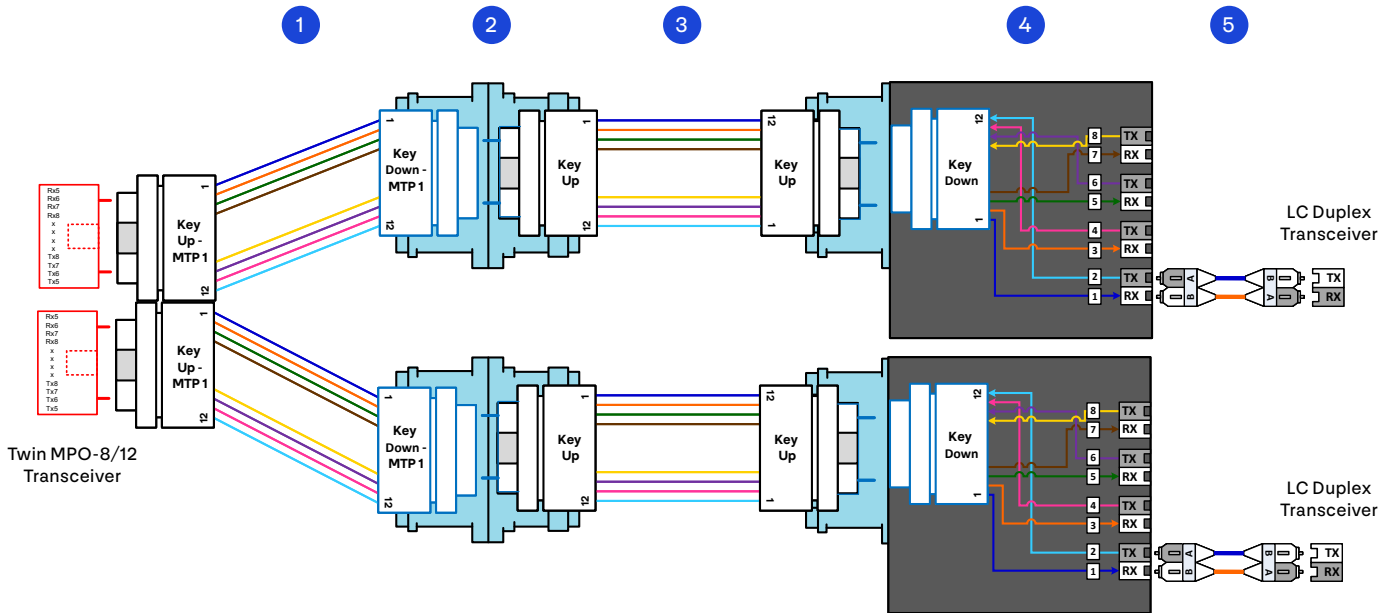

Use Case B

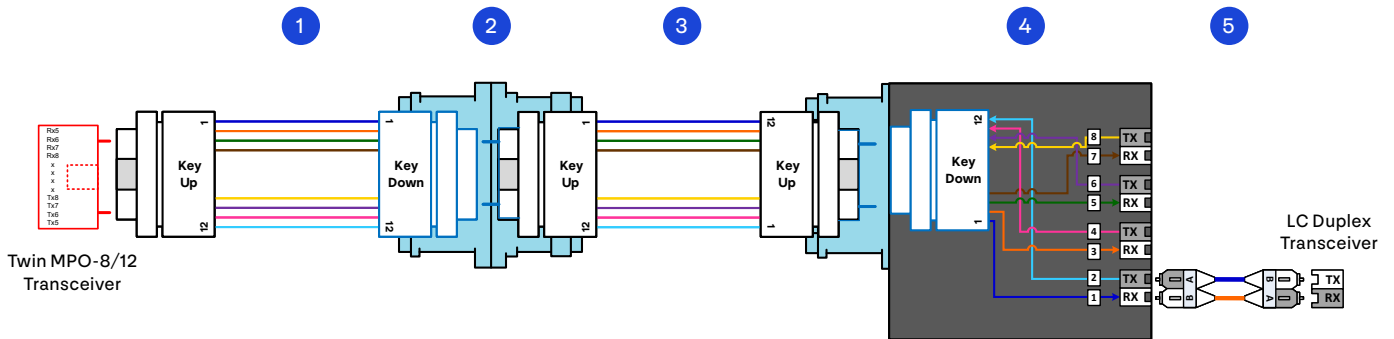

Scenario 11 – MPO-12 PC to MPO-12 PC Using Point-to-Point Cabling

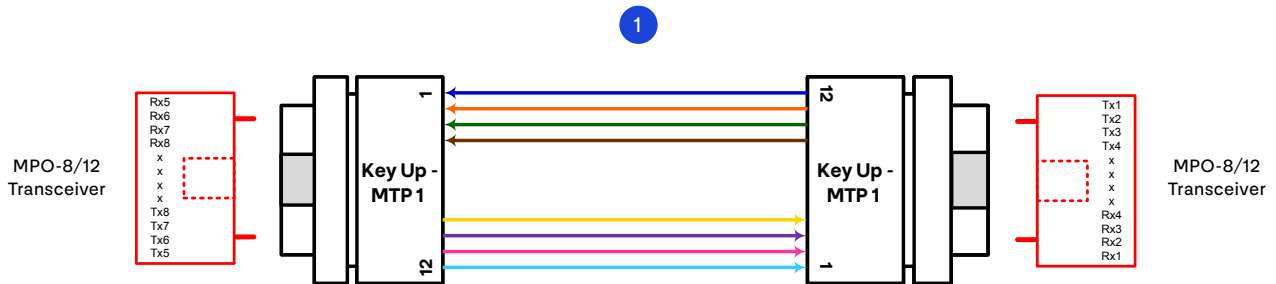

Scenario 12 – MPO-12 PC to MPO-12 PC Using Structured Cabling

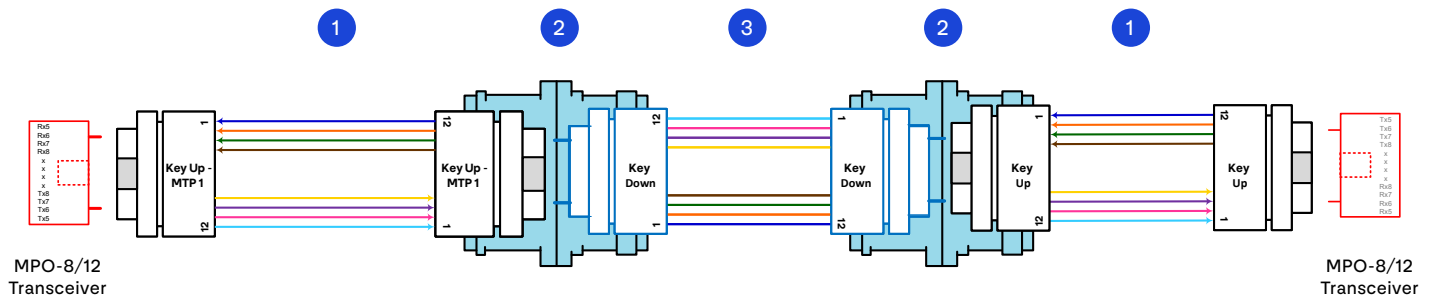

Scenario 13 – MPO-12 PC to LC Duplex Using Point-to-Point Cabling

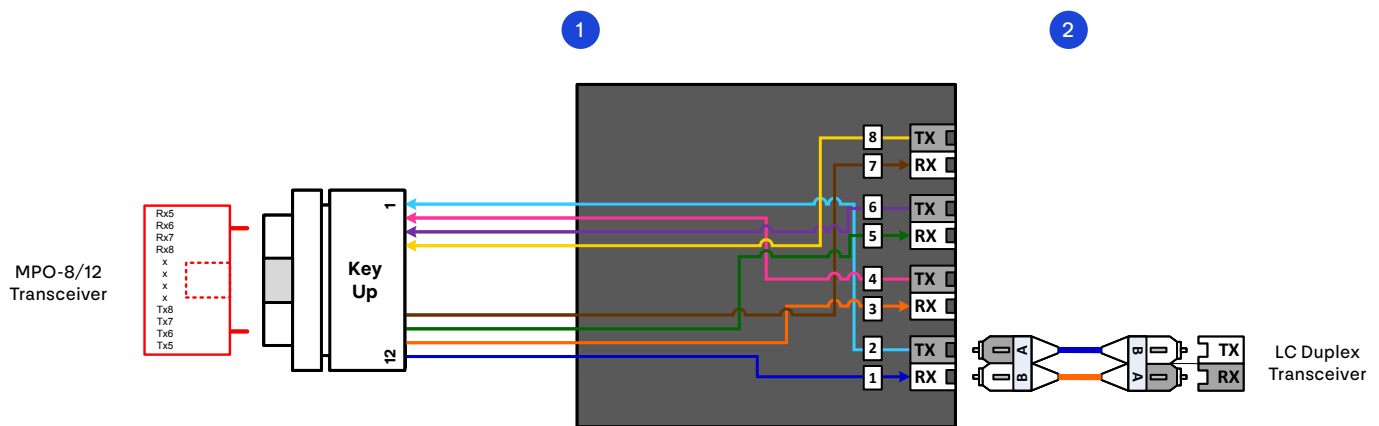

Scenario 14 – MPO-12 PC to LC Duplex Using Structured Cabling

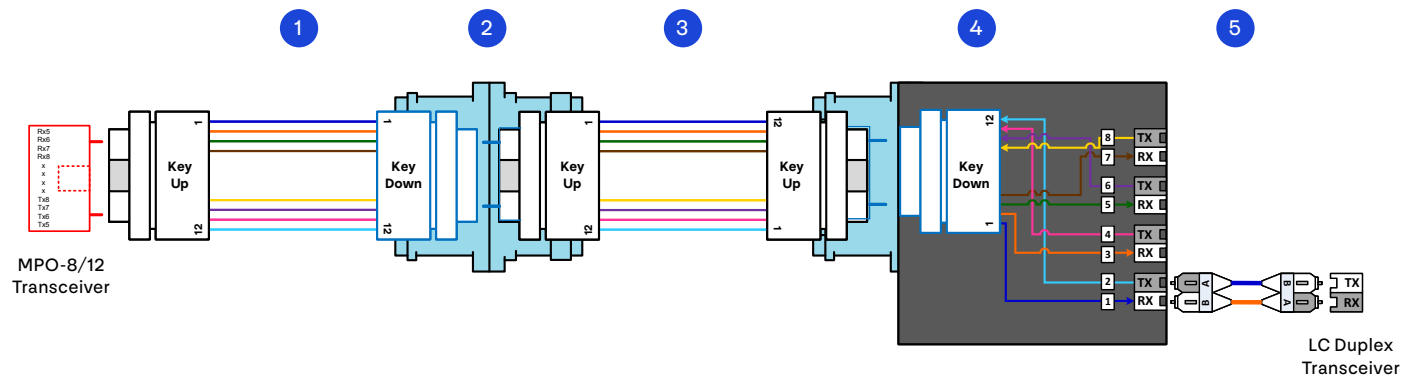

Scenario 15 – LC Duplex to LC Duplex Using Point-to-Point Cabling

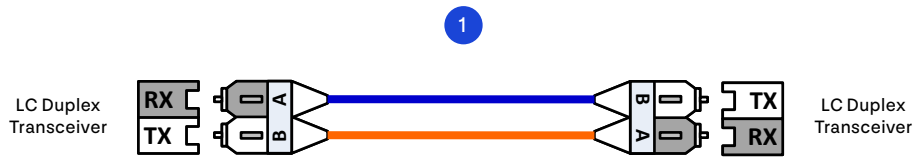

Scenario 16 – LC Duplex to LC Duplex Using Structured Cabling

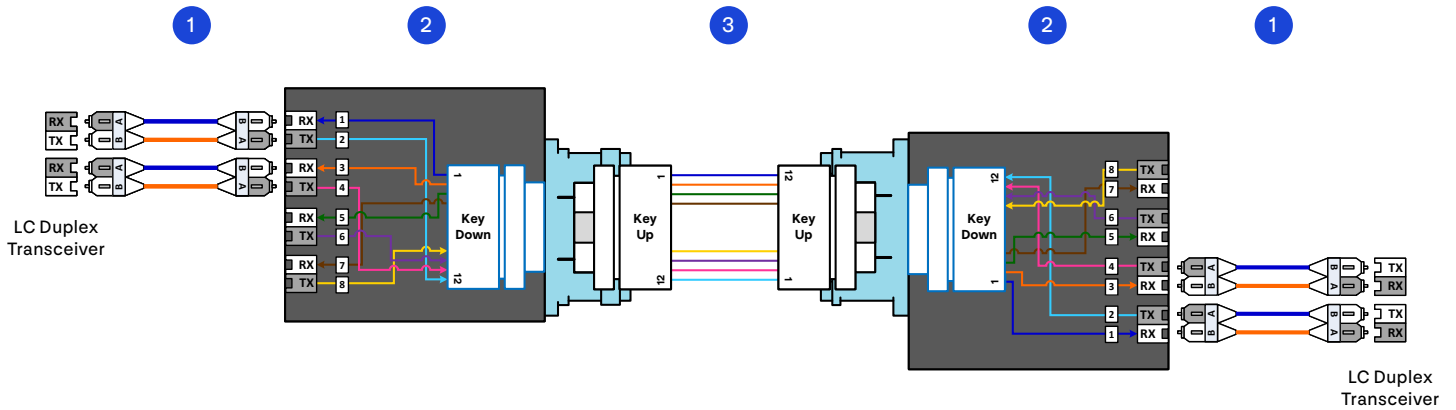

CORNING

For questions, please contact Corning's Technical Support Line:

Americas

Phone: 800-743-2671

Email: dutyeng@corning.com

EMEA and APJ

Phone: +49 305 303 2134

Email: engineer.en.emea@corning.com

Corning Optical Communications LLC • 4200 Corning Place • Charlotte, NC 28216 USA
800-743-2675 • FAX: 828-325-5060 • International: +1-828-901-5000 • www.corning.com/opcomm

Corning Optical Communications reserves the right to improve, enhance, and modify the features and specifications of Corning Optical Communications products without prior notification. A complete listing of the trademarks of Corning Optical Communications is available at www.corning.com/opcomm/trademarks. All other trademarks are the properties of their respective owners. Corning Optical Communications is ISO 9001 certified. © 2020, 2025 Corning Optical Communications. All rights reserved. LAN-2495-AEN / January 2025