

# CORNING

## SLiC<sup>®</sup> Fiber Aerial Terminal Closure with External Adapter SLFT 530-D

P/N 78-8135-4264-0

Issue 6

[related literature](#) | [Search corning.com/opcomm](#). Click on “Resources/Standard Recommended Procedures.”

### INSTRUCTIONS

## 1.0 KIT CONTENTS

- A. Closure Body and Terminal Box Assembly
  - Tray Strap (1)
  - Cable Management Tray Frame (1)
  - Strength member retainers (2)
- B. Hose Clamps (2)
- C. End Seals (2)

The Corning® SLiC® Fiber Aerial Terminal Closure 530 is now equipped with the standard bracket and (a.) below.



## OPTIONAL ACCESSORIES

- A. Offset Hanger Bracket (AC-HB4)
- B. 2 in. tall Aerial Hanger Bracket (AC-HB2)

**Note: Visually inspect all components. If any component is missing or appears damaged, do not install. Call Corning Customer Care at 800-743-2675 for a replacement product.**

Splice Tray Kit 2527 (select units only)

- A. Tray
- B. Cover
- C. Log Label
- D. 6" (150 mm) Ribbon Retention Grommet
- E. Cable Ties (12)
- F. Corning Single Fusion Splice Holder\*
- G. Corning Mass Fusion/Fibrlok® Splice Holder\*
- H. 6" (150 mm) Transition Tube Retainer
- I. Fiber Saddle Clips (3)
- J. Reclosable Fasteners (4)

\* Tray kit will contain either Single or Mass Fusion/Fibrlok sleeve holders, depending on configuration ordered.

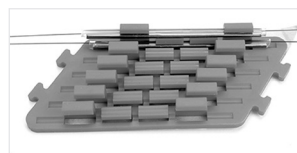
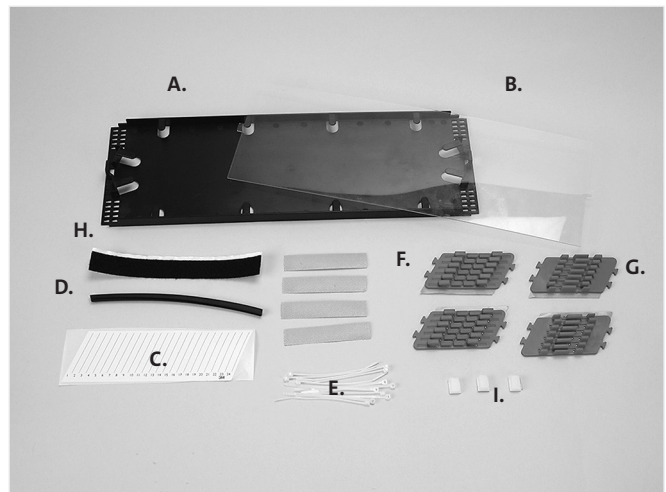

Single Fusion Splice Holder (12)



Mass Fusion/Fibrlok Splice

MILLIMETERS	10	15	20
RANGES	A	B	C
INCHES	.4	.6	.8

## 2.0 GROUND BRAID INSTALLATION FOR SHIELDED CABLES

**2.1** Remove existing hanger bracket bolts and attach Corning Grounding Braid 25T-BBE3 with eyelets spaced at three inches between each hanger bracket behind terminal frame. Leave two eyelets per end to attach to shielded cables.

**2.2** Route braid behind frame and away from splice trays as shown. Tighten hanger bolts to 40 to 45 in.-lbs. with terminal wrench.

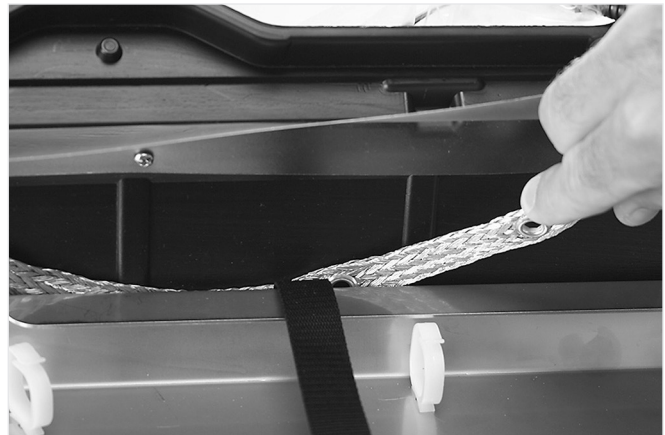

## 3.0 HANGING TERMINAL

**3.1** The aerial hanger bracket is designed to fit on different size strands.



For small strand diameters



For large strand diameters

**3.2** Loosen bolt and hang closure on strand by placing bolt on top of the strand.

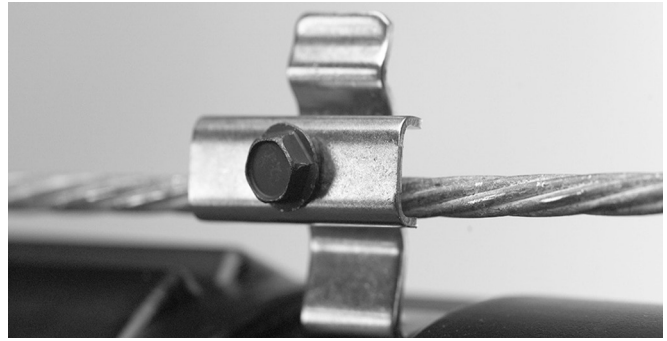

**3.3** Rotate clamp until correct clamp groove is over the strand and tighten bolt to 40 to 45 in.-lbs. with terminal wrench.



### **3.4 Offset Hanger Bracket Installation**

**3.4a** Remove installed hanger bracket with terminal wrench.

**3.4b** Install the offset hanger brackets onto terminal as shown. Tighten mounting screw to 40 to 45 in.-lbs. with terminal wrench.

**3.4c** Remove the notched caps and cap bolts from the original hanger brackets and secure in place on the offset brackets.

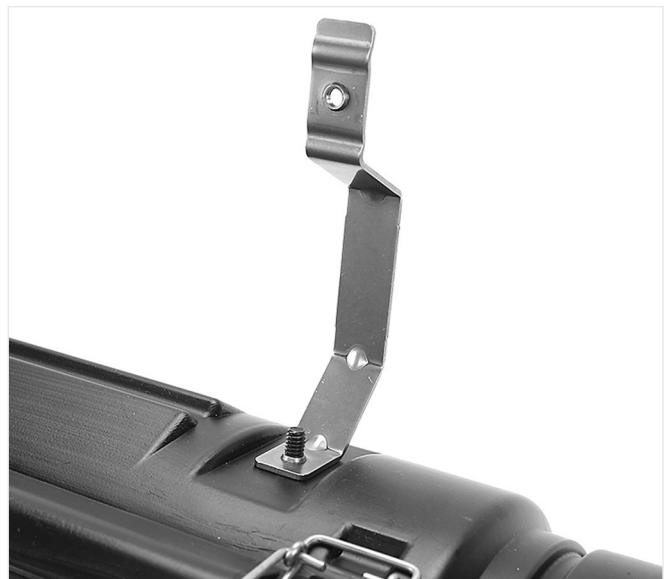

## 4.0 CABLE INSTALLATION - LOOSE BUFFER

(for Taut Sheath Applications see Section 8)

\* Baffles not shown for clarity

**4.1** Open closure by opening latches and unlocking them from plastic catches.

**Tip: Grip latches on their sides as shown rather than trying to pry them from the ends.**

**4.2** Remove 5' to 9' of cable sheath, per company practice.

**4.3** Clean cable if grease is present. Corning® Filled Cable Cleaning Kit 4414 or Corning Service Wire Cleaning Kit 4415 is recommended.

**Note: Carefully follow safety, health, and environmental information given on product label or the Safety Data Sheet (SDS).**

**4.4** Unwind buffer tubes down to central strength member of the cable.

**4.5** Cable Preparation

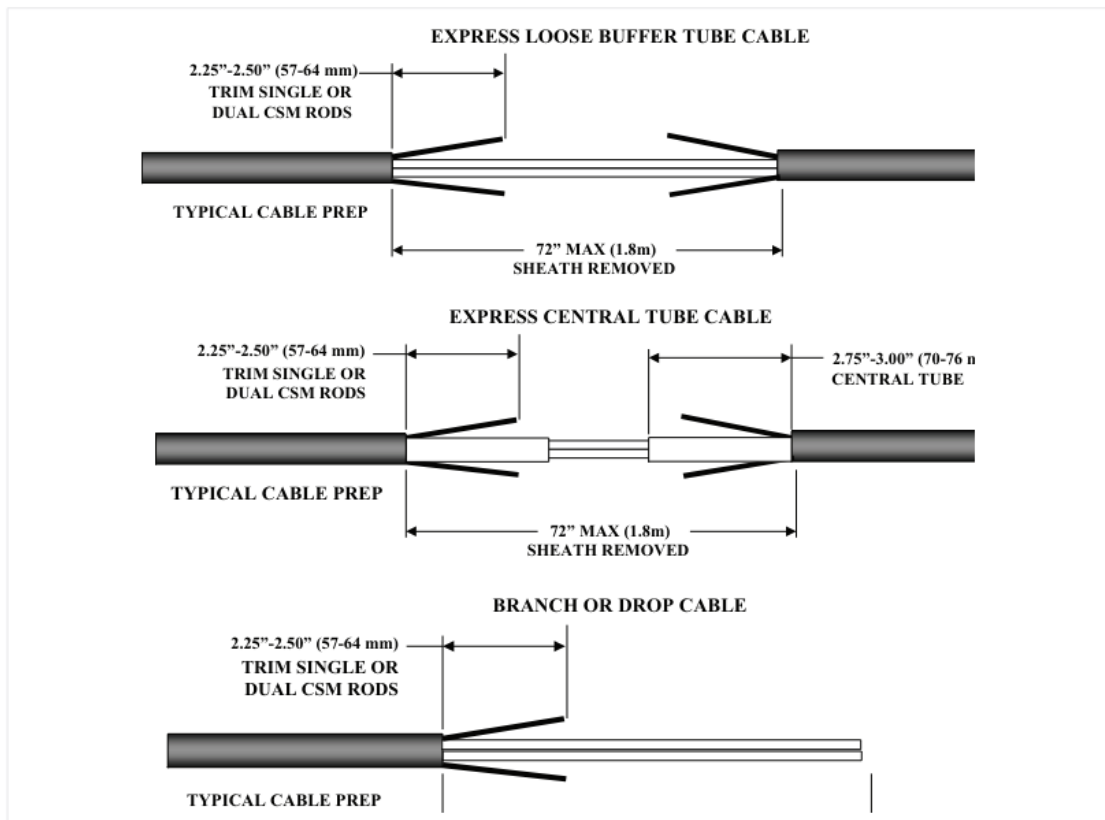

**4.6** For All-Dielectric cables, attach cable(s) to cable management tray frame using hose clamp(s) provided. Using terminal wrench, tighten hose clamp to approximately 25 to 30 in.-lbs.

**Note:** *When attaching cable(s) to tray frame, insure that a min. .25" of cable jacket is left exposed past the hose clamp.*

**Note:** *Frame is designed for either butt or inline configuration.*

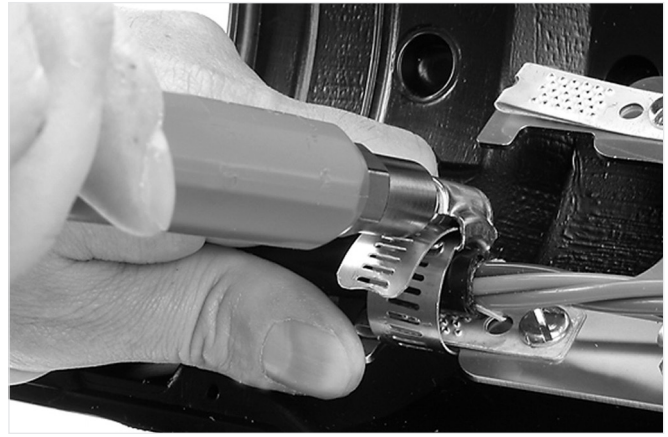

**4.6a** Position central strength member(s) under CSM retainer(s) and tighten screws to approximately 25 to 30 in.-lbs. with a #2 Phillips drive screwdriver.

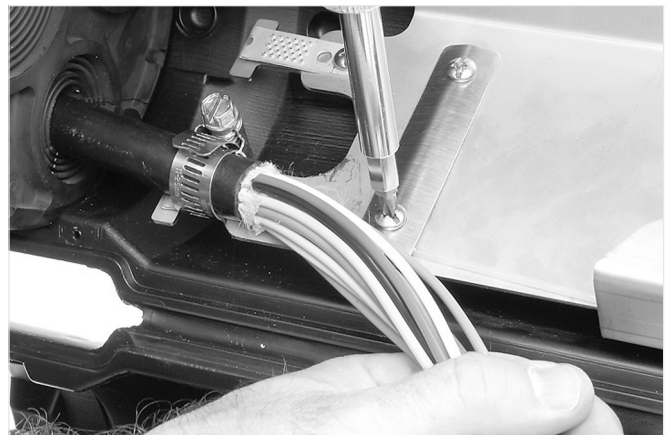
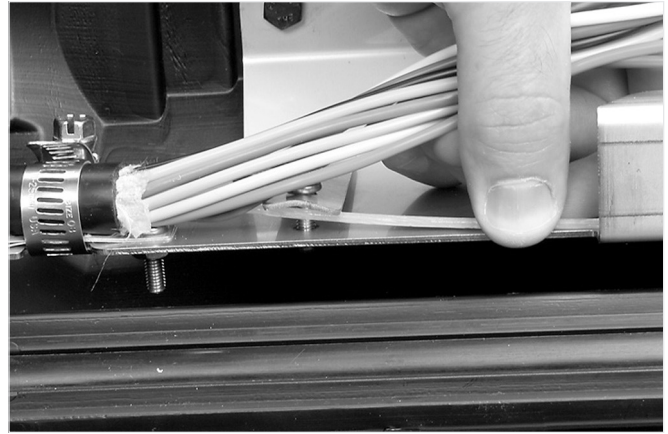

**4.6b** Arrange slack coil and slide inside cable management tray frame.

**Note:** *Do not exceed minimum cable bend radius as prescribed by cable manufacturer.*

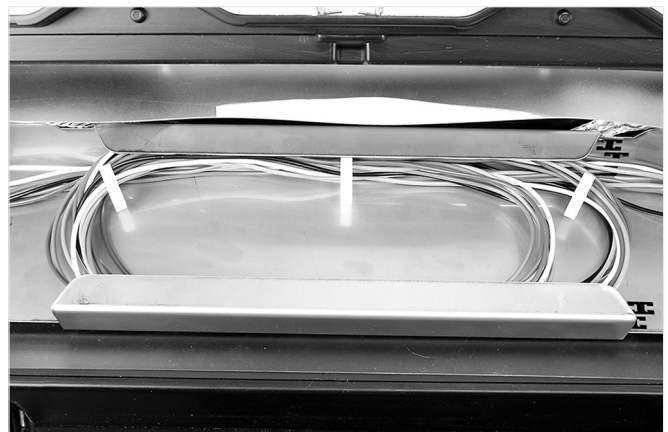

**4.6d** When deploying an express cable configuration, cut off buffer tube or ribbon to be spliced as close to the field side of the cable loop as possible.

**4.6e** Carefully remove buffer tube or ribbon to be spliced.

**4.6f** Cable tie remaining buffer tubes or ribbon together for added strength and ease of management.

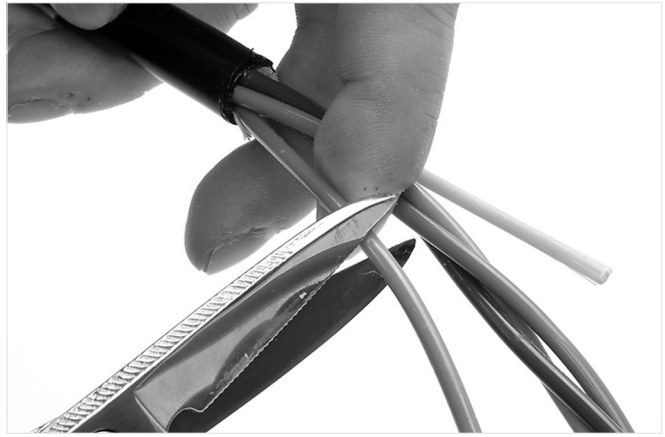

**4.7** For armored or shielded cables, attach cable(s) to cable management tray frame using hose clamp(s) provided. Using terminal wrench, tighten hose clamp to approximately 25 to 30 in.-lbs. When installing shielded cable, you must install Shield Bond Connectors 4460-D or 4460-D/FO per installation instructions.

**For 4460-D**

**4.7a** Install central strength member under CSM retainer and tighten screws to approximately 25 to 30 in.-lbs. with a #2 Phillips drive screwdriver. See Fig. 1.

**For 4460-D/FO**

**4.7b** Install connector as shown. Remove central strength member clamp.



Shield Bond Connector 4460-D Installation



Shield Bond Connector 4460-D/FO Installation

## 5.0 CABLE INSTALLATION - RIBBON

(for Taut Sheath Applications, see Section 8)

\*Baffles not shown for clarity

**5.1** Follow steps 3.1 to 3.5

**5.2** Carefully remove ribbon from central tubes to be spliced.

**5.3** For All-Dielectric cables, attach cable(s) to cable management tray frame using hose clamp(s) provided. Use terminal wrench to tighten hose clamps to approximately 25 to 30 in.-lbs.

**Note: When attaching cable(s) to tray frame, insure that a minimum of 0.25" (6 mm) of cable jacket is left exposed past the hose clamp.**

**5.4** If cable is shielded, follow instructions in 3.7 above.

**5.5** Position dual strength member(s) under CSM retainer and tighten screws to approximately 25 to 30 in.-lbs.

**Note: Do not exceed minimum cable bend radius as prescribed by cable manufacturer.**

**5.6** Cut 0.75" to 1.00" (19-25 mm) transition tube retainer for each transition tubing. Prepare transition tubing by positioning Scotchmate approximately 0.25" (6 mm) from end of transition tubing as shown in Fig. 3.

**Note: Only wrap transition tube retainer around the top portion of the tube, allowing tubing to make contact with splice tray. See Fig. 3. Trim if needed.**

**5.7** Install cable tie as shown for either one or two transition tubes. Assure you are leaving the locking end of the cable tie in a position that will have it end up on top of the transition tube when tie is cinched.

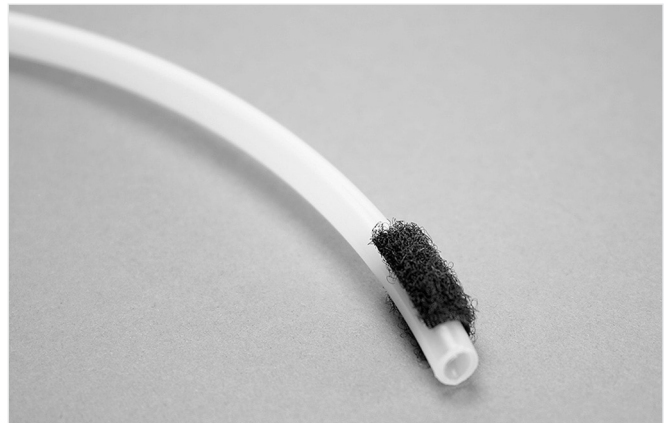

**5.8** Install transition tubing and cinch up cable ties.

**5.9** Installation complete with one transition tube and cable ties trimmed.

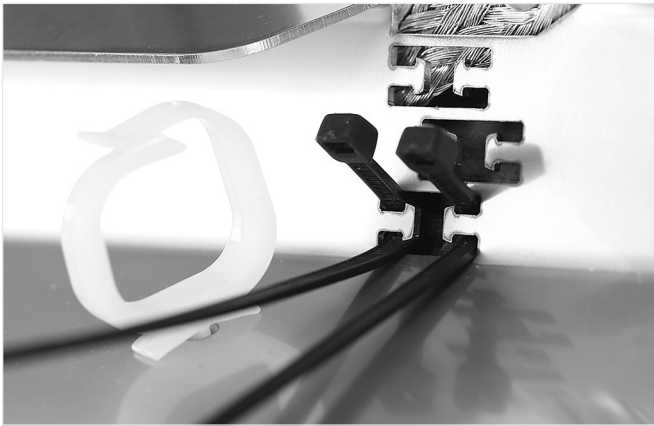

One transition tube installation

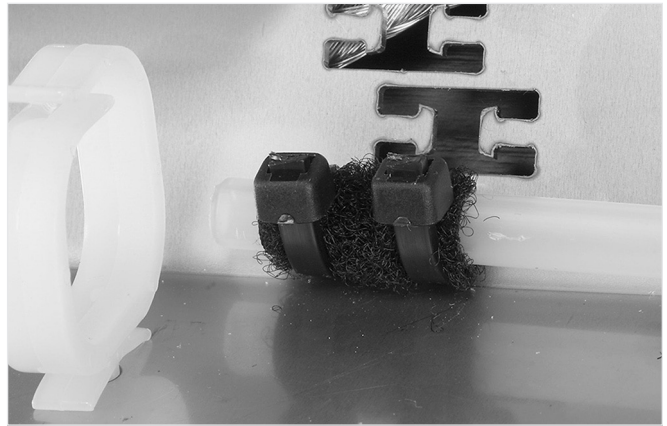

**5.10** Installation complete with two transition tubes and cable ties trimmed.

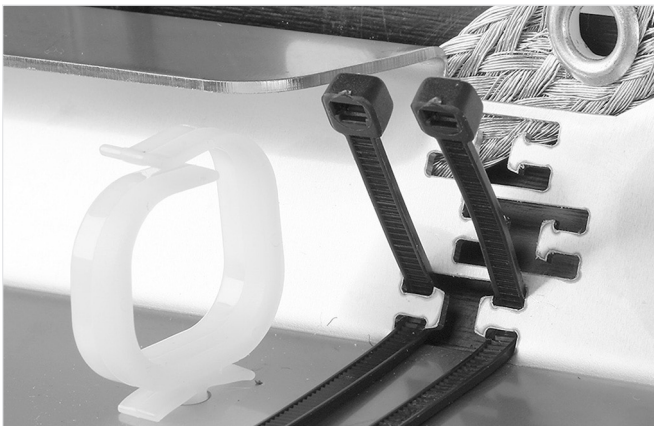

Two transition tube installation



**5.11** Route ribbon fiber as needed to complete installation.



## 6.0 END SEAL INSTALLATION

**6.1** With cable(s) securely clamped in place, install end seals, routing cable(s) through small ports.

**6.2** Use the guide provided on the bottom of page 2 to select range to cut end seal.

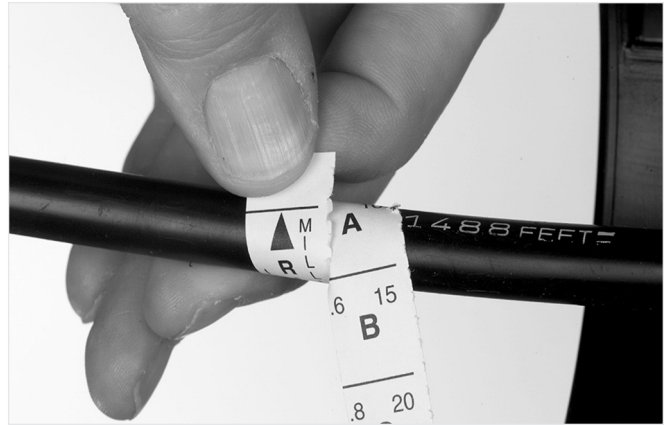

**6.3** Unfold end seal halves.

**6.4** On selected end seal port, puncture and cut through range letter on logo side of each seal half.

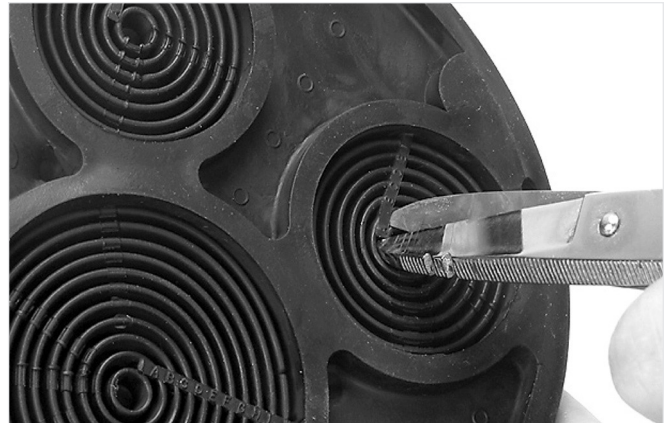

**6.5** Cut end seal from outside edge to install on existing cable.



**6.6** Tear out the selected ring.

**Note:** Check fit prior to cutting other half of end seal.



**6.7** Install end seal on cable(s), just outside the closure end and lock alignment pins in place.

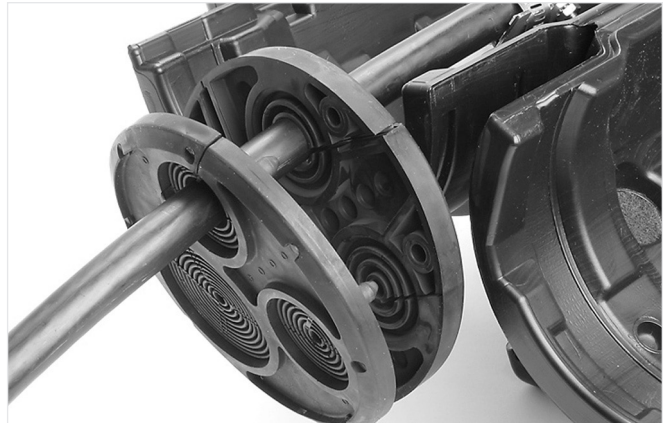
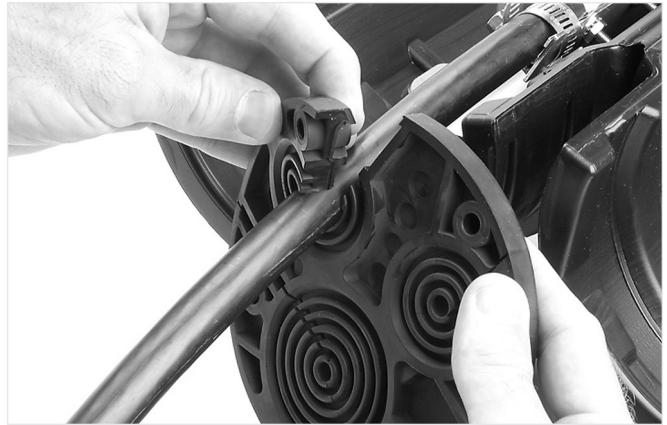

**6.8** Slide end seal into place and seat into molded pocket.

**Note:** End seal can be assembled with thin side on left or right side.

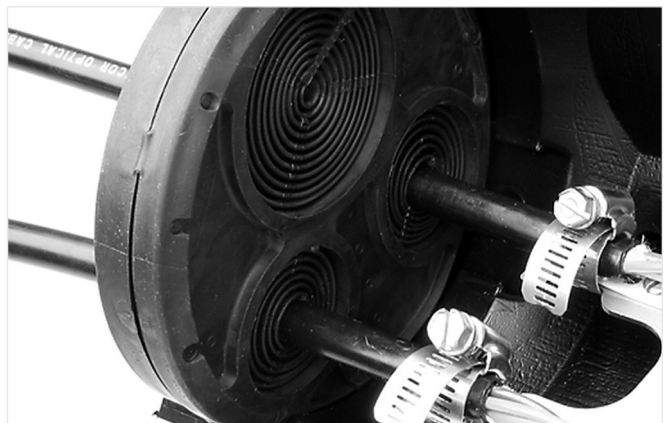

## 7.0 TRAY INSTALLATION

**7.1** Place the pieces of reclosable fasteners material face to face and snap together.

**7.2** Remove backing from one side and center on the upper and lower lips of the cable management tray frame. The material edge should be aligned with edge of frame as shown.

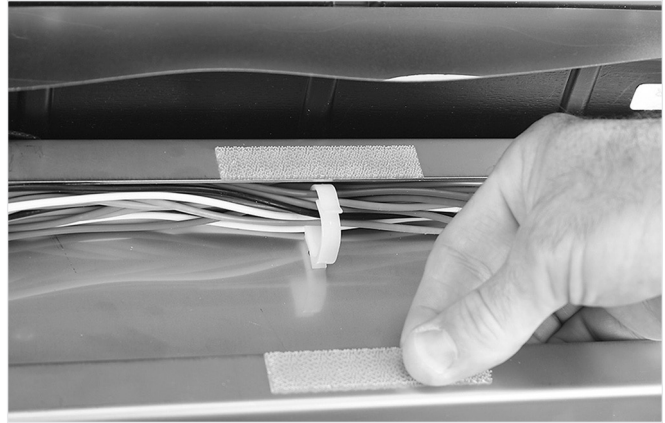

**7.3** Remove the backing from the top of the material, position fiber tray over adhesive and press down firmly. For non-taut sheath applications tray should be centered on cable management tray frame. (For taut sheath application location see section 8).

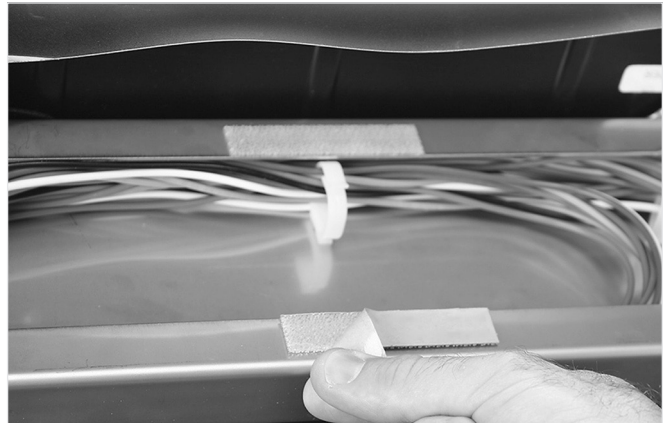

## 8.0 FIBER MANAGEMENT INSIDE TRAY

**8.1** Select appropriate Splice Holder based on type of splicing to be performed.

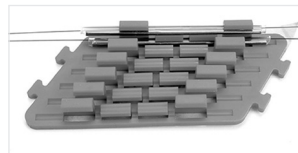

Single Fusion Splice Holder (12)



Mass Fusion/Fibrlok Splice

**8.2** Remove adhesive backing and position splice holders on tray.

**Note: Positioning of splice holders should be such that a minimum of 1.5" bend radius is maintained for each fiber to be spliced.**

**Note: In a contaminated environment, use your company-approved cleaner (i.e. isopropyl alcohol) to clean tray surface for better adhesion.**

### 8.3 Ribbon Not in Transition Tube

**8.3a** Route ribbon to desired tray corner. Place ribbon fiber into 1 to 1.5 in. of ribbon retention strip (cut segments as needed from supplied length) and secure assembly into tray using supplied cable tied. (A maximum of 6 ribbons can be loaded into each retention grommet segment).

**Note: Do NOT use pliers to tighten cable ties to tray. Cable ties should be hand tightened such that ribbon or buffer tube are immobilized. Over tightening can cause microbends, damage to buffer tubes, or ribbon fibers.**

### 8.4 Ribbon in Transition Tube

**8.4a** Route ribbon within transition tube to desired corner. Adhere 0.75" - 1.00" strip of transition tube retainer to transition tubing (cut segments as needed from supplied length) and secure assembly into tray using supplied cable ties.

### 8.5 Loose Buffer Tube

**8.5a** Route buffer tube to desired tray corner. Secure loose buffer tube to tray using the supplied cable ties (as shown).

**Note: Do not exceed minimum 1.5" bend radius during routing process.**

### 8.6 Ribbon Fanout

**8.6a** Place ribbon fanout into 1" to 1.5" of ribbon retention strip (cut segments as needed from supplied length) and secure assembly into tray using supplied cable ties. The ribbon fanout can only be routed to the bottom corner of the tray on the side of the terminal where the ribbon fanout exits/enters the terminal box.

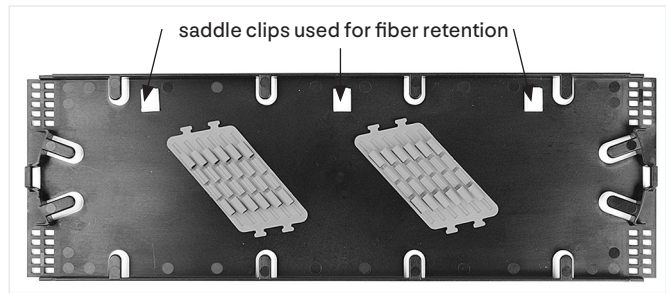

Ribbon retention

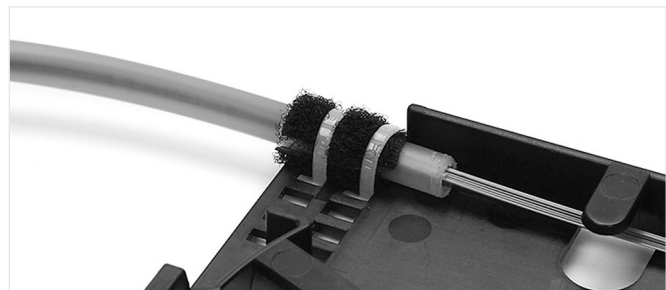

Ribbon with transition tubing

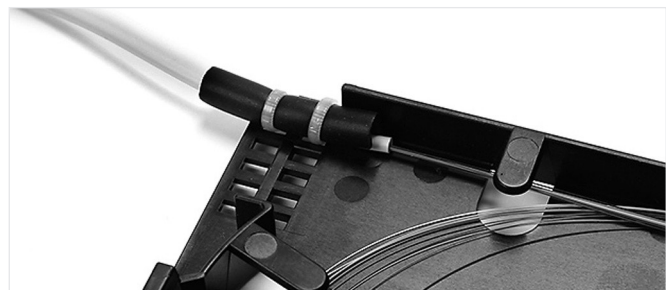

Discrete LBT

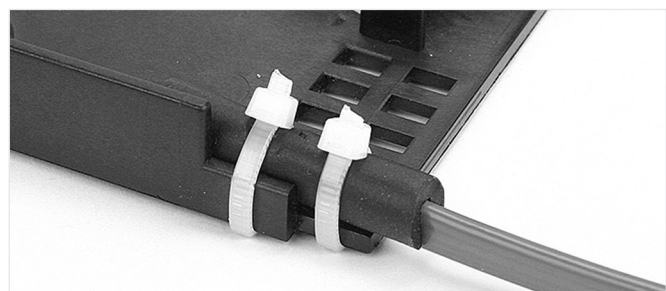

Ribbon fanout

## 8.7 Pigtailed In Corrugated Tubing

**8.7a** Route tubing with pigtailed into top right corner of splice tray only. Extend tubing 1" to 1.5" into tray and secure using supplied cable ties.

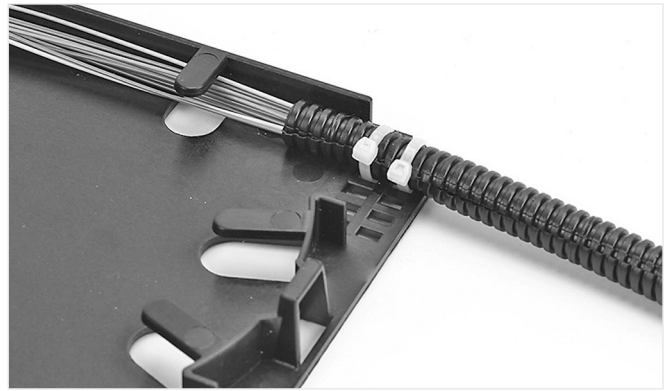

Pigtailed In Corrugated Tubing

**8.8** Splice fiber and place sleeves into splice holders.

**8.9** Place label on tray cover where desired.

**8.10** Tie trays together as shown, if needed.

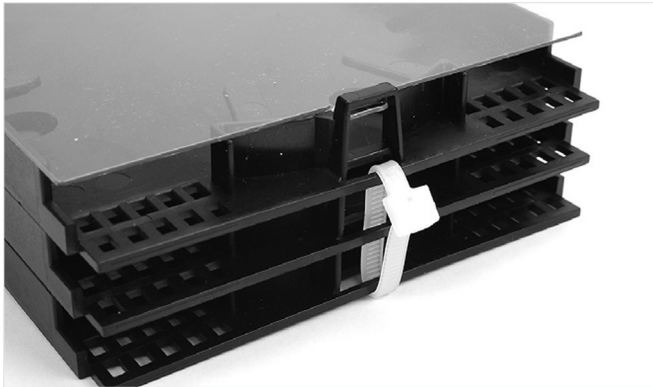

Securing at tabs

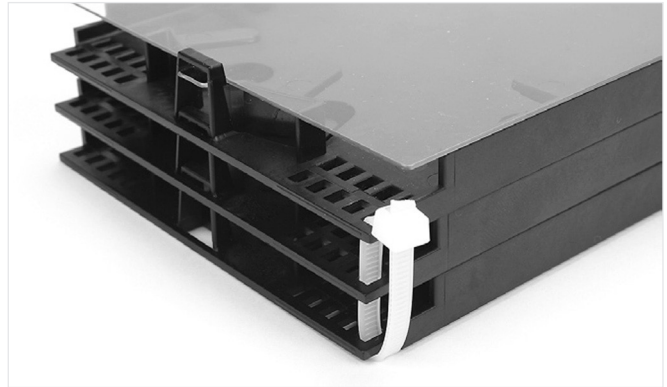

Securing at corners

## 9.0 TAUT SHEATH APPLICATION

**9.1** Remove a maximum of 26" of sheath and subsequent layers from the cable to access the buffer tubes or ribbon.

**9.2** Cut the buffer tube or ribbon to be spliced as close to the field side of the sheath opening as possible.

**9.3** Carefully unwind the cut buffer tube or ribbon from remaining bundle and clean grease, if present.

**9.4** Mount the closure so that sheath opening is centered on cable management tray frame.

**9.5** Mount tray to cable management tray frame biased to the Central Office side of closure as shown. (See previous section for tray mounting procedure.)

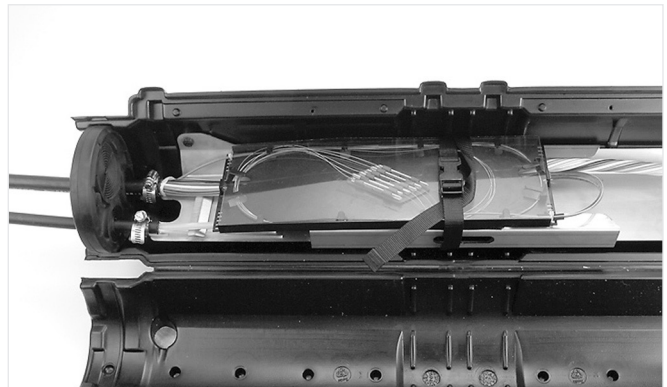

**9.6** Route buffer tube into tray, leaving 0.5" to 1" of buffer tube inside the tray entrance point.

**9.7** Remove the remaining length of buffer tube and clean grease from fibers.

**9.8** Follow instructions in previous sections for tray mounting, splicing and end seal preparation.

**Note:** Do not cut central strength members. Leave intact and skip Section 3.5 and Section 3.10.

## 10.0 DROP INSTALLATION

**10.1** Remove dust cap from external adaptor.

**Note:** It is recommended that the connector inside the terminal be thoroughly cleaned and reconnected. Connector cleaner is recommended.

**Note:** Carefully follow safety, health, and environmental information given on product label or the Safety Data Sheet (SDS).



**10.2** Remove dust cap from drop cable assembly.



**10.3** Align keyed features, insert connector into external adaptor and screw collar on drop connector into adaptor until secured.



**10.4** Screw external adapter dust cap into cable assembly dust cap for added security.

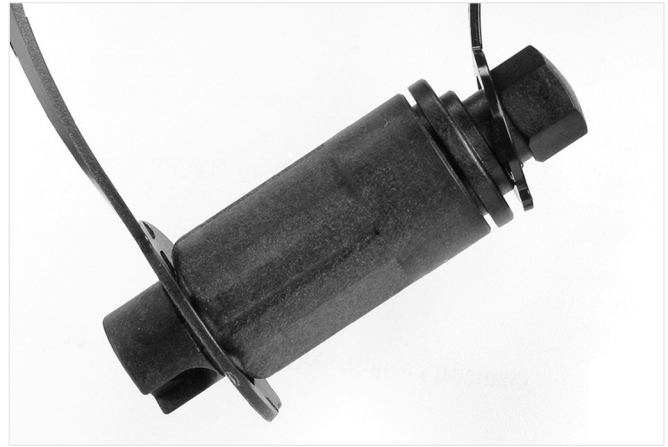

## 11.0 ACCESSORIES

Item	Part Number
4460-D	80-6104-1486-6
4460-D/FO	80-6108-4444-3
25T-BBE3	80-6100-9614-3
AC-HB2	80-6108-4677-8
AC-HB4	80-6113-1470-1
2527 Tray Kit	80-6111-7558-1
Connector Cleaner	90-0212-3293-3