

# CORNING

## EDGE™ Solutions Fiber Optic Cable Assembly

P/N 004-133-AEN, Issue 5

related literature | Search [www.corning.com/opcomm](http://www.corning.com/opcomm). Click on “Resources.”

003-794

EDGE™ Solution

### 1. Jumper and Harness Handling Procedures

Fiber optic cables are sensitive to excessive pulling, bending, and crushing forces. Consult the specification sheet for the cables you are installing. Replacement of the cable may be necessary if any of these conditions occur.

 **CAUTION:** The illustrations depict correct and incorrect cabling handling. Never move or pull the cable by pulling on its connector legs.



TPA-7117

### 2. Connector Cleaning and Care

Corning recommends using the CLEANER-PORT-LC when cleaning LC connector end-faces when installed in an adapter and when in jumper format. Likewise, when cleaning MTP® connector end-faces in jumper and adapters, Corning suggests using 2104466-01. One additional cleaning tool (CLEANER-UNIV-CASS) can be used to clean any single-fiber or multifiber connector not installed in an adapter.

**NOTE:** Always keep a clean dust cap on unused connectors.

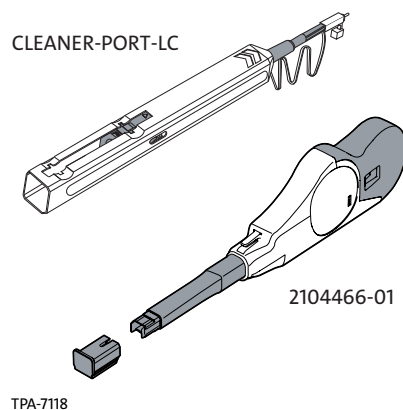

TPA-7118

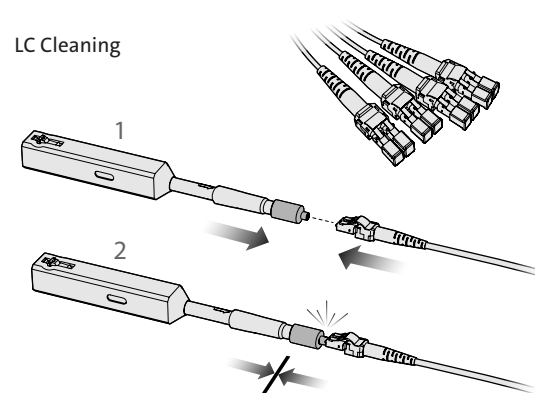

### 3. Changing the Polarity of an LC Uniboot Connector (Standard Version)

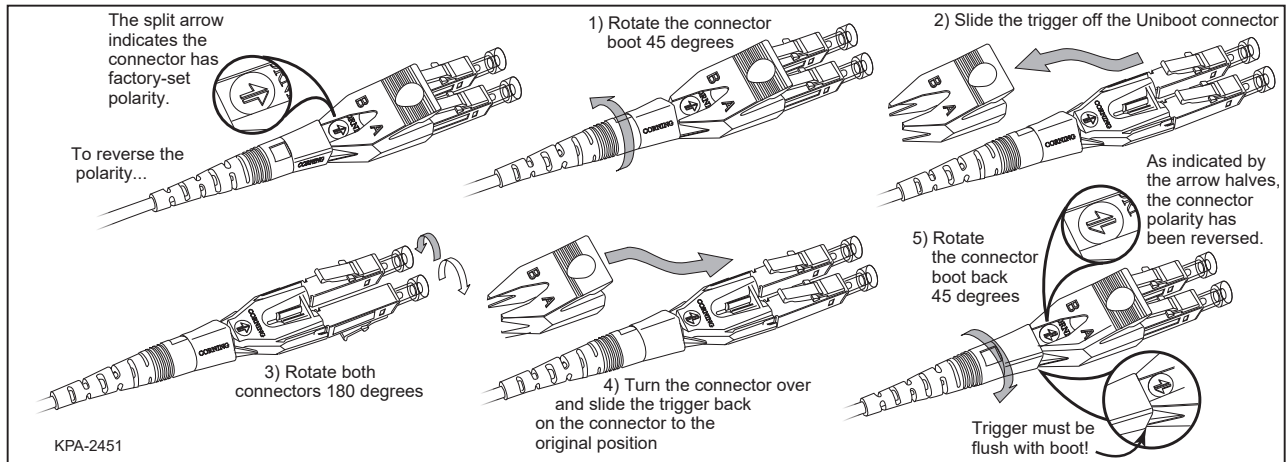

### 4. Changing the Polarity of a Lockable LC Uniboot Connector (Lockable Version)

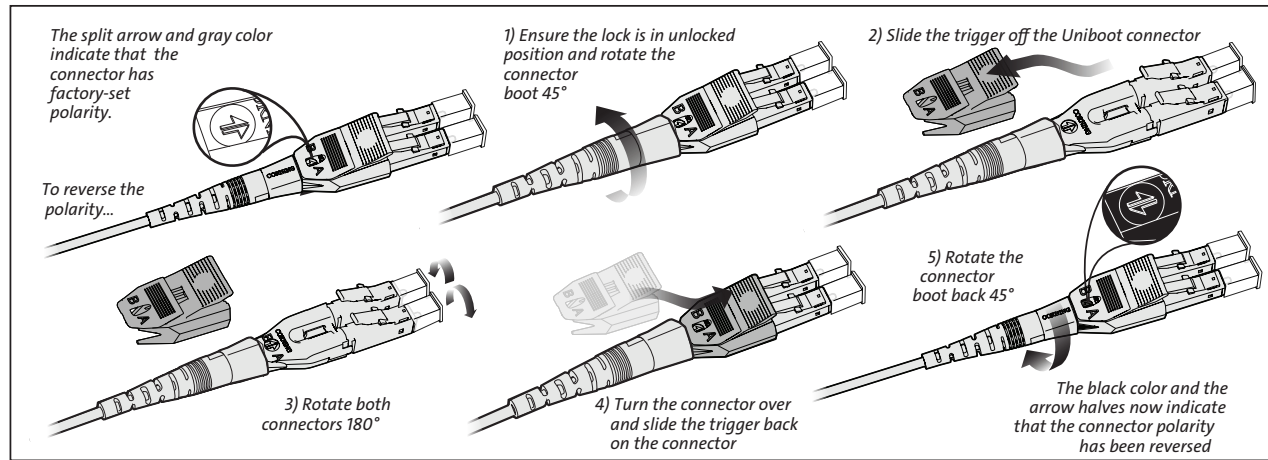

### 5. Locking and Unlocking a Lockable LC Uniboot Connector

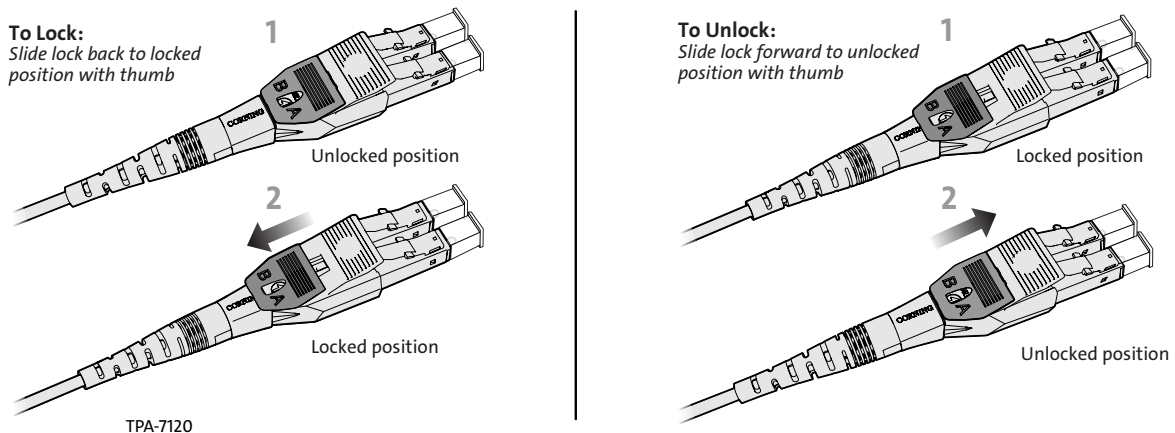

Corning Optical Communications LLC • 4200 Corning Place • Charlotte, NC 28216 USA  
800-743-2675 • FAX: 828-325-5060 • International: +1-828-901-5000 • [www.corning.com/opcomm](http://www.corning.com/opcomm)

Corning Optical Communications reserves the right to improve, enhance, and modify the features and specifications of Corning Optical Communications products without prior notification. A complete listing of the trademarks of Corning Optical Communications is available at [www.corning.com/opcomm/trademarks](http://www.corning.com/opcomm/trademarks). All other trademarks are the properties of their respective owners. Corning Optical Communications is ISO 9001 certified. © 2009, 2011, 2015, 2021 Corning Optical Communications. All rights reserved.