

related literature | visit <http://www.corning.com/opcomm/>

003-1002-AEN Instruction, EDGE8™ Solution

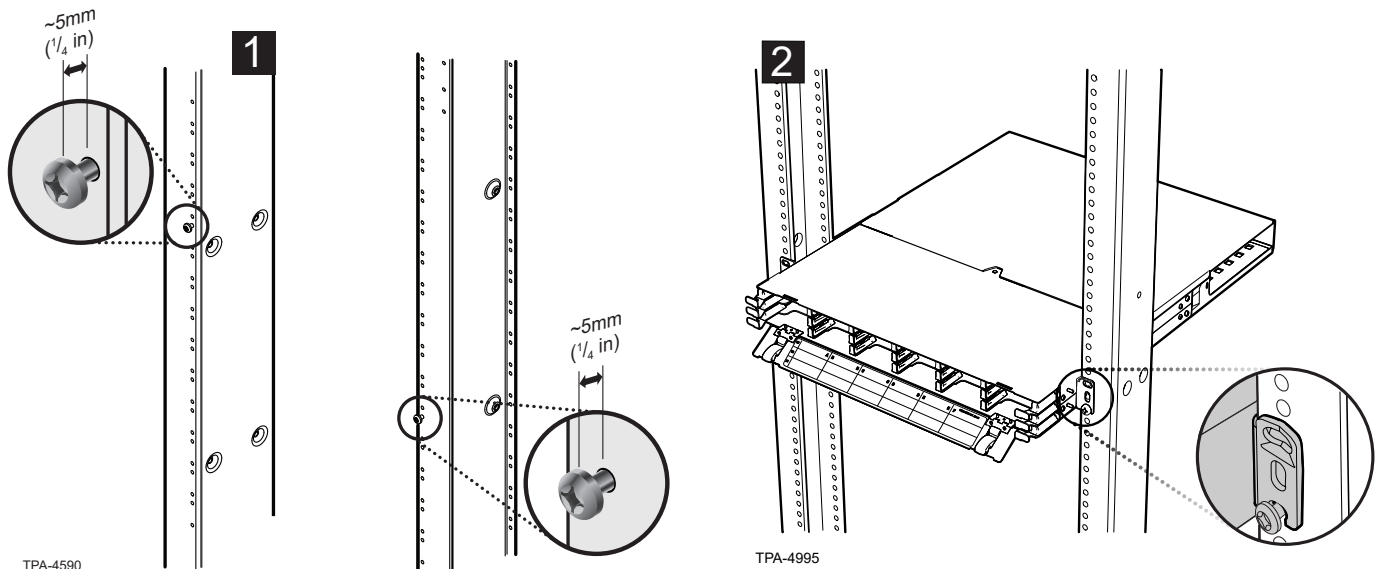

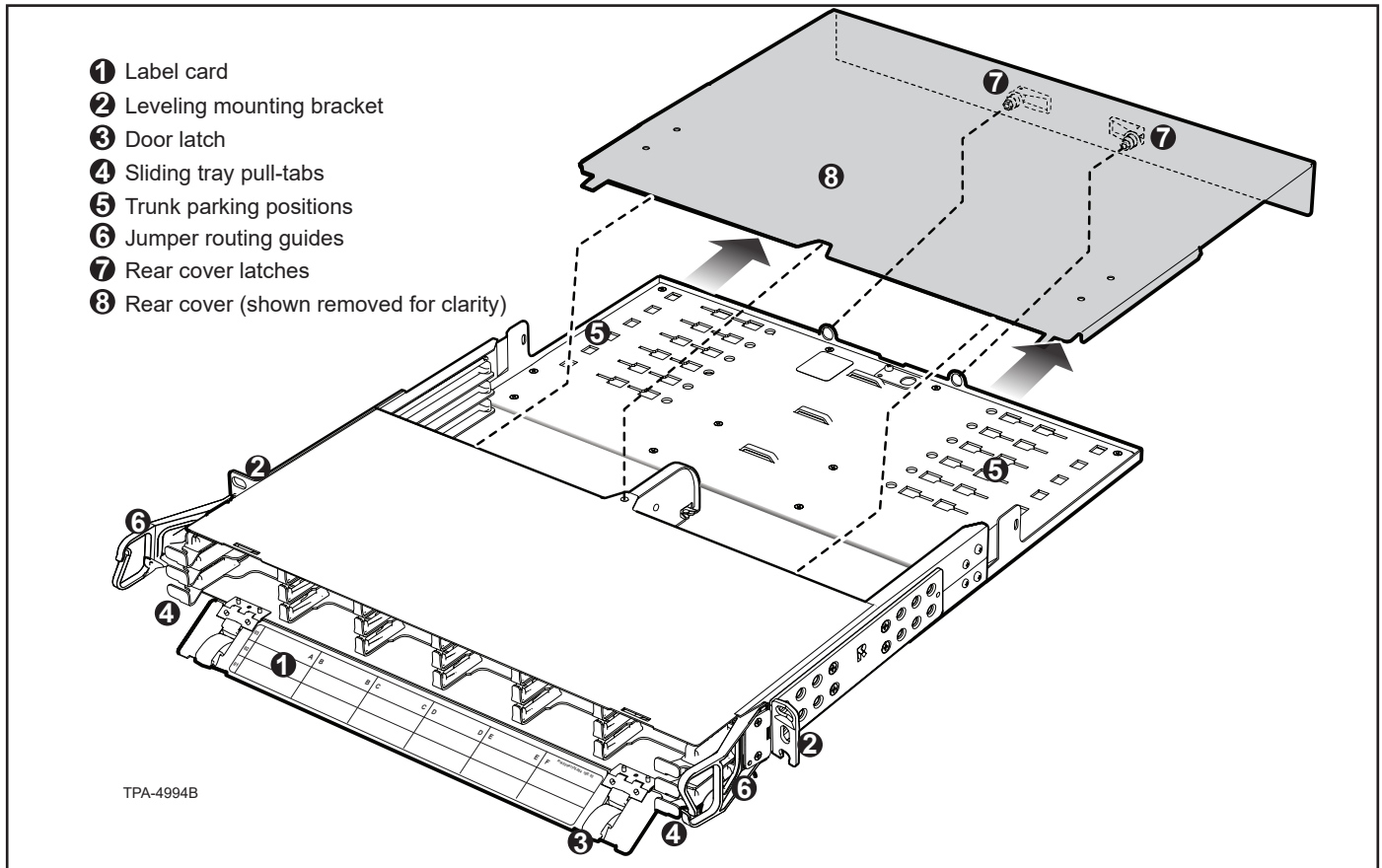
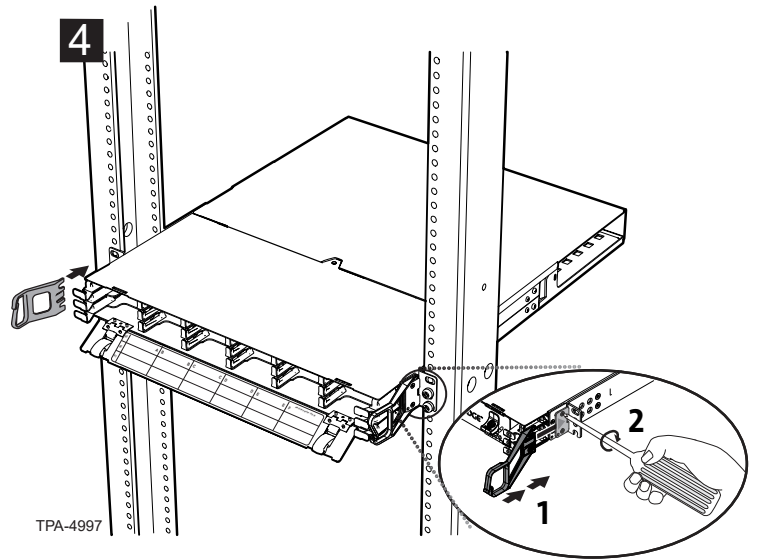
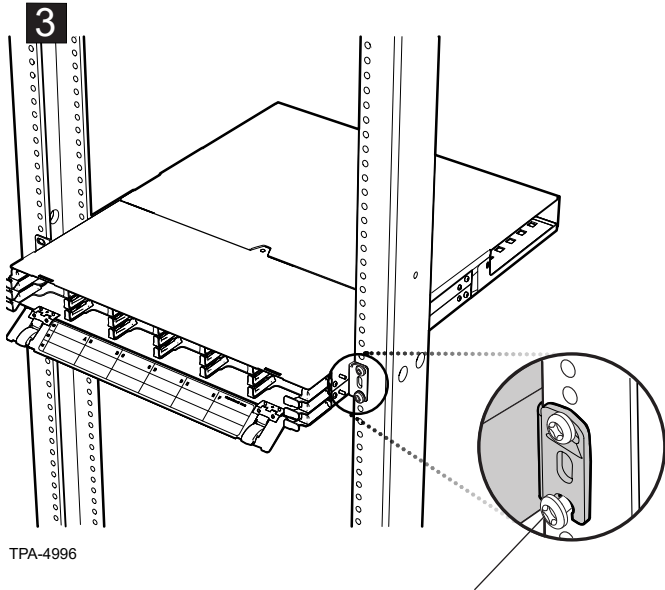

NOTE: Use this screw to optimize housing's level.

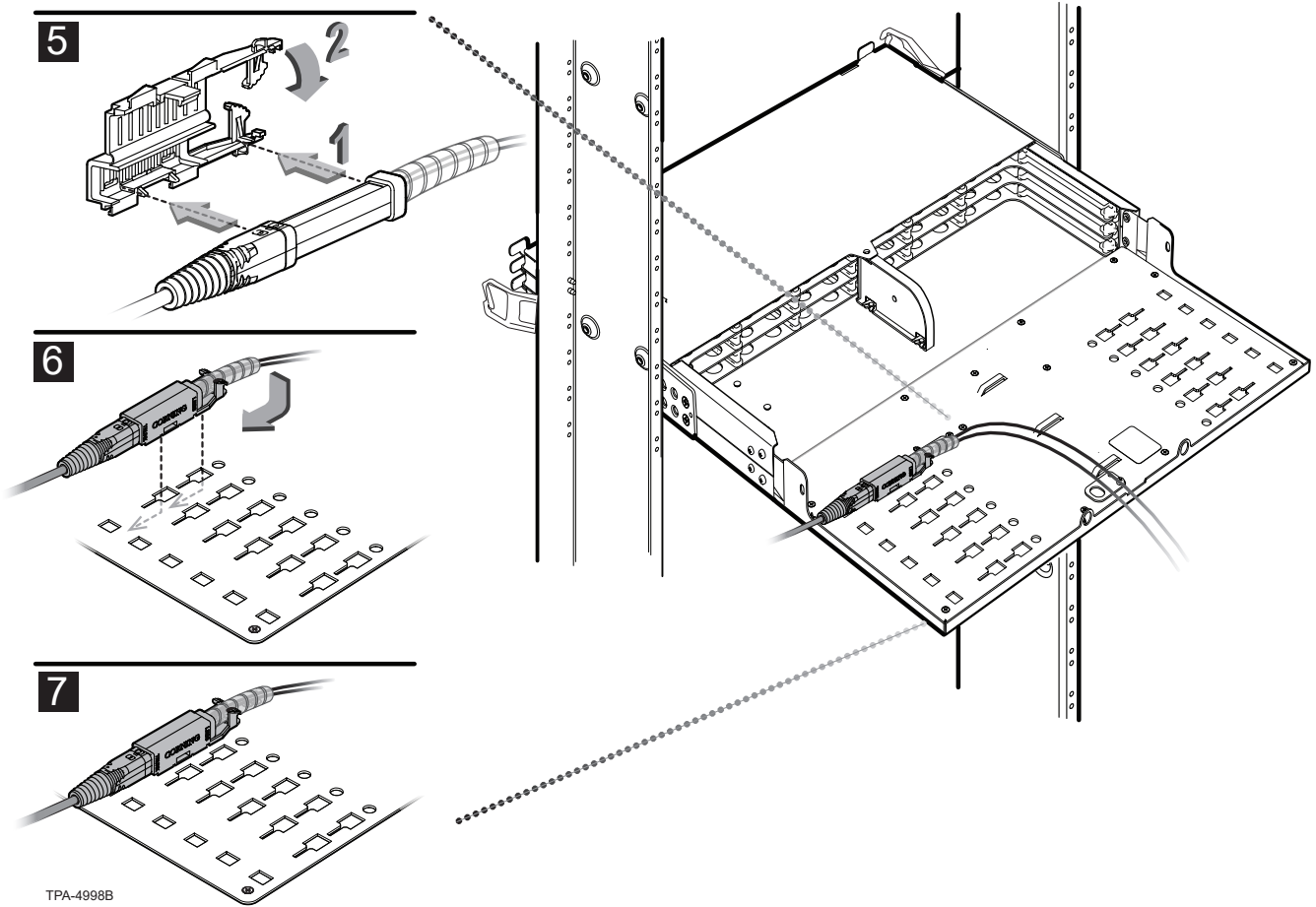

8

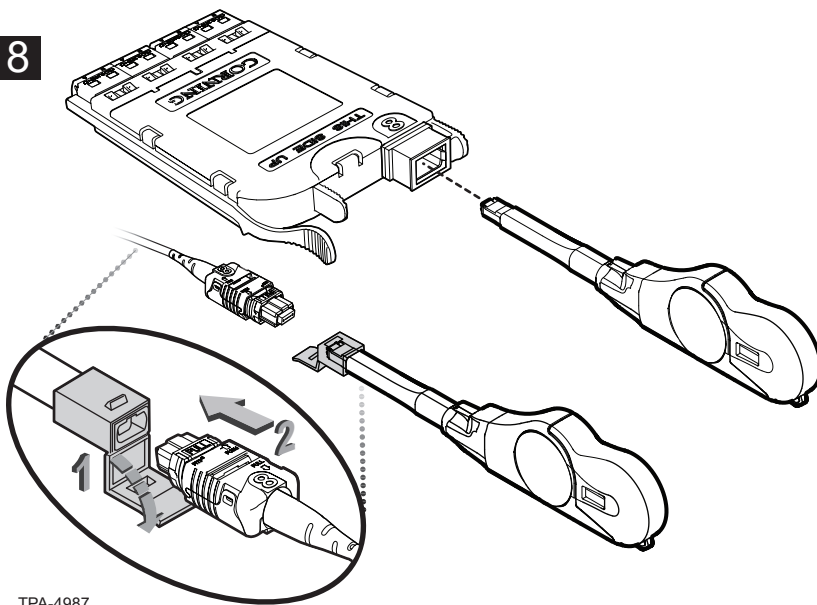

TPA-4987

9

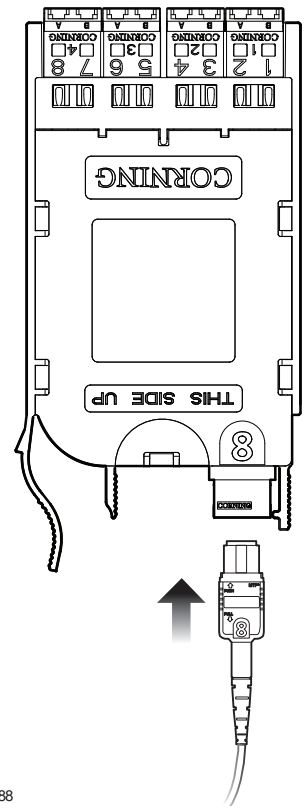

TPA-4988

10

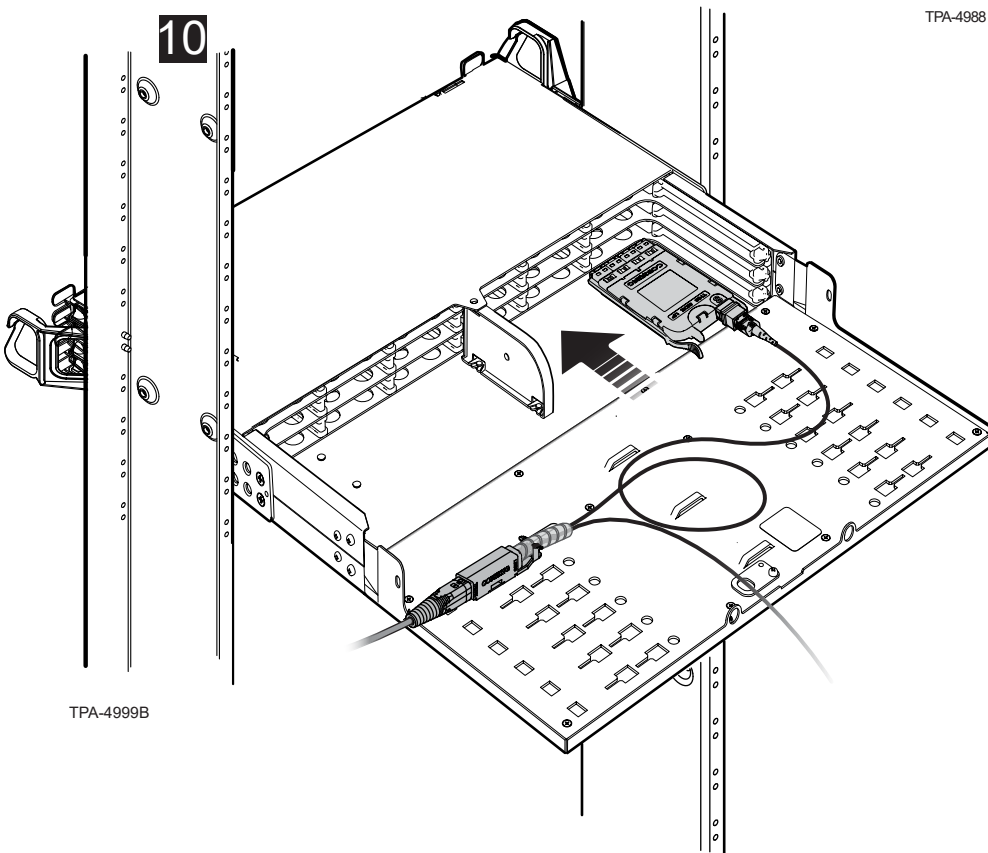

TPA-4999B

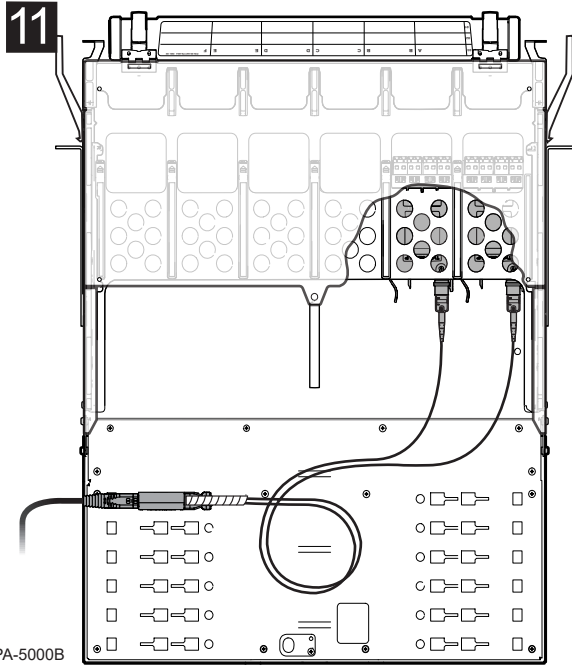

TPA-5000B

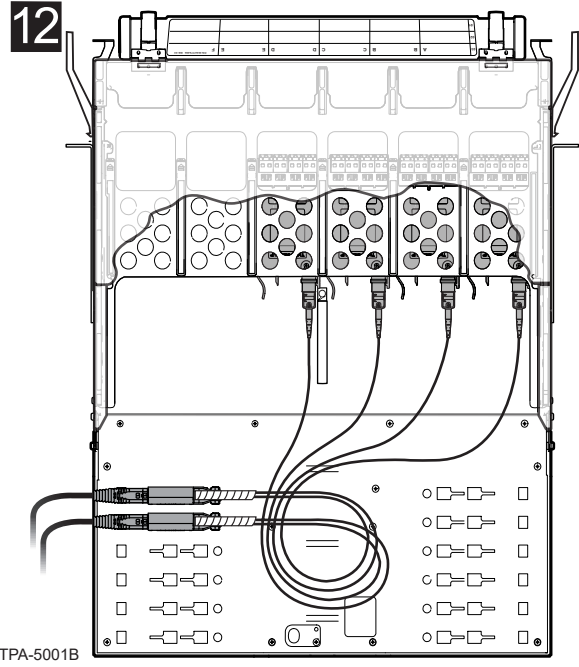

TPA-5001B

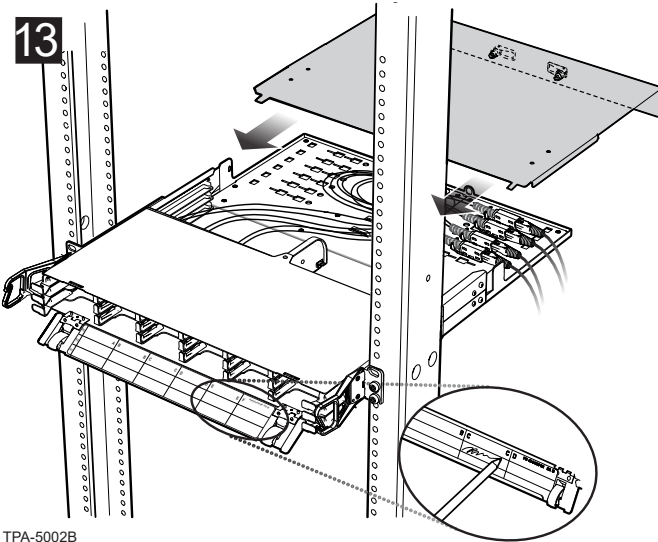

TPA-5002B

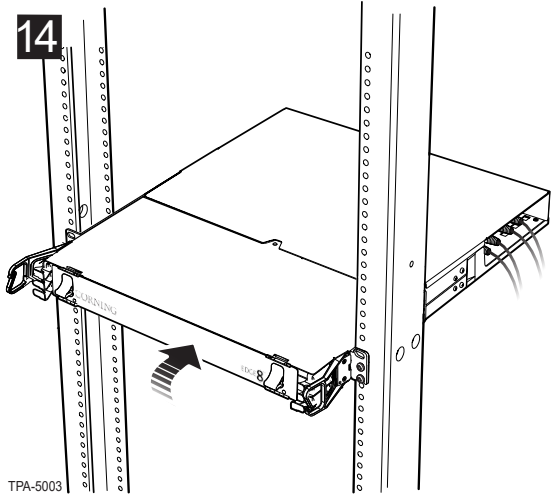

TPA-5003

Corning Optical Communications LLC • 4200 Corning Place • Charlotte, NC 28216 USA
 800-743-2675 • FAX: 828-325-5060 • International: +1-828-901-5000 • corning.com/opcomm

Corning Optical Communications reserves the right to improve, enhance, and modify the features and specifications of Corning Optical Communications products without prior notification. A complete listing of the trademarks of Corning Optical Communications is available at www.corning.com/opcomm/trademarks. All other trademarks are the properties of their respective owners. Corning Optical Communications is ISO 9001 certified. © 2015, 2018, 2020, 2022, 2024 Corning Optical Communications. All rights reserved.