

Optical Tap Module Connectivity Solutions for Network Monitoring

AEN164, Revision 3

This Application Engineering Note discusses the different Corning Optical Communications Optical Tap module offerings and how to integrate them in the different infrastructure networks for effective passive network monitoring solutions. Optical taps are used to extract data from optical networks for network performance and optimization, security threats and for troubleshooting purposes. This is accomplished by inserting the optical tap within the cable infrastructure system either as a standalone optical split inside an LC/LC module, or the optical split is integrated in a MTP®/LC or an all MTP module as part of the infrastructure component. Corning tap modules use high performance, thin-film splitter technology which does not induce any BER penalties in Multimode applications. This splitter technology allows for the flexibility of installing them anywhere in the system without BER effect. The tap module infrastructure connectivity systems discussed in this application note are based on Corning's Base-8 (eight fiber) and Base-12 (12 fiber) cabling product solutions found in the EDGE8®, EDGE™ and Plug and Play™ pre-terminated solutions. For examples of fiber optic systems utilizing Base-12 pre-terminated connectivity solutions, please refer to AEN151 "Four-Channel Parallel Optic Connectivity Solutions Utilizing Base-12 Structured Cabling" and AEN152 "Four-channel Parallel to Duplex Optical Connectivity Solutions Utilizing Base-12 Structured Cabling". For Base-8 solutions, please refer to AEN156 "Connectivity Solutions Utilizing Base-8 Structured Cabling". The different Tap module offerings and connectivity within the infrastructure will be illustrated.

A Bill of Materials (BOMs) to implement the different scenarios, with product part numbers, will be provided with OM4 Laser-Optimized 50µm multimode and OS2 single-mode fiber in both the EDGE8 and EDGE product families. The tap modules in the BOMs will have 50/50 split ratios, but additional split ratios are available depending on fiber type and application requirements. The phrase, remote monitoring, will be used to represent optical links where the tapping equipment is not located in the rack or adjacent racks to the location of the tap modules, hence it will be cabled across the data center through trunk cables. The polarity drawing for the scenarios are presented in appendix A.

Corning Tap Module Configurations

An optical tap could either be integrated or non-integrated into infrastructure cabling. The different tap module configurations are optimized for use in different cable infrastructure systems for monitoring different protocol data rate transmissions. These different configurations come in different split ratio e.g. 50/50, 70/30 in Multimode and 50/50, 70/30, 80/20, 90/10 in Single mode. For considerations and guidance in establishing the maximum supportable link distances for the different protocol data rate transmissions based on the tap

splitter ratio and the number of loss connectivity component in the system please refer AEN162 –“Maximum Distance Capabilities for Corning Optical Communications’ Pre-Terminated Solutions”. Tap modules are characterized with three types of ports – Two LIVE ports for live traffic in/out of the module and TAP port for the tapped/filtered signals. These ports are in either LC or MTP representation, with the LIVE port connector in the color code of the fiber type and the TAP Port connector in the red color. Corning tap modules come in both Non-Integrated and Integrated and are grouped into three configurations based on the connector type representation of the signal port sequence – LIVE/TAP/LIVE.

Configuration A Tap Module

The first tap module configuration that will be discussed is the LC/LC/LC non-integrated tap module configuration, see Figure 1. The input live LC port fibers are split inside the module and routed to the output live port and two receive monitor LC ports in front of the module. Configuration A tap modules are deployed as standalone modules requiring an additional housing to tap an already existing duplex infrastructure system. Connections are made to both the live and monitor devices via LC duplex jumpers. Specific non-integrated tap modules are capable of splitting WDM/CWDM data rate transmissions at the different applicable wavelength lanes for tapping, e.g. 40G BiDi and 40G LR4. Non-integrated taps are available in the EDGE and EDGE8 module footprint.

Figure 1: Configuration A EDGE Tap Modules



Configuration B Tap Module

The next configuration is the MTP/MTP/LC Integrated tap module configuration, see Figure 2. The LIVE MTP port is located at the rear of the module. The fibers from the MTP are split inside the module and routed to LIVE LC ports in front of the module and TAP MTP port in the rear of the module. Configuration B Tap module is wired in accordance with the Corning Universal polarity making them compatible with all Corning Universal polarity system components. Tapped signals are routed to the monitor device via a tap MTP to LC simplex harness breakout. Configuration B tap modules can be used to support and monitor serial duplex transmissions and Parallel transmission breakout applications, e.g. 10G and 40G to 4 X 10G port breakout respectively. Within the infrastructure system, a Configuration B tap module functions like a normal Universal wired module, while also sending the split signal to the MTP TAP port. This allows for the flexibility to monitor via the TAP port at any time without disrupting the live network. Configuration B tap modules can also be used as a standalone item to port replicate duplex equipment ports using MTP/LC harness and cross-connect to a duplex infrastructure system with LC jumpers.

CORNING

Figure 2: Configuration B EDGE Tap Modules

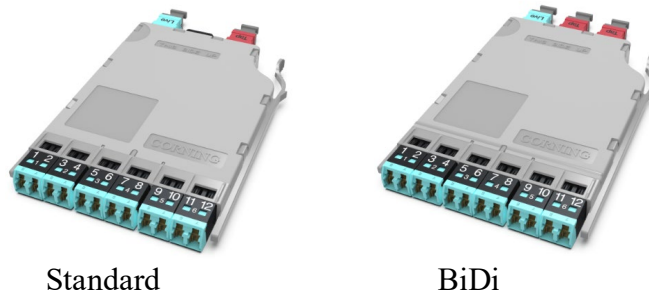

Configuration C Tap Module

The last configuration is the MTP/MTP/MTP integrated tap module configuration, see Figure 3. The two MTP LIVE ports are located in the front and rear of the module. Input signals from the LIVE Port are filtered and routed to the TAP MTP port that can be front or rear facing. Configuration C Tap modules are wired as a TIA 568 Type B component on the LIVE link and either TIA 568 Type A or B to the TAP port. The integrated MTP TAP port allows for the flexibility to monitor at any time without disrupting the live network. Configuration C tap modules can be used to support and monitor duplex transmissions and Parallel transmission protocols using MTP to LC harness breakouts or MTP jumpers respectively. The modules can be used to future proof the infrastructure components when planning to migrate from serial 10G to higher data rate using parallel transmission protocol.

Figure 3: Configuration C EDGE Tap Modules

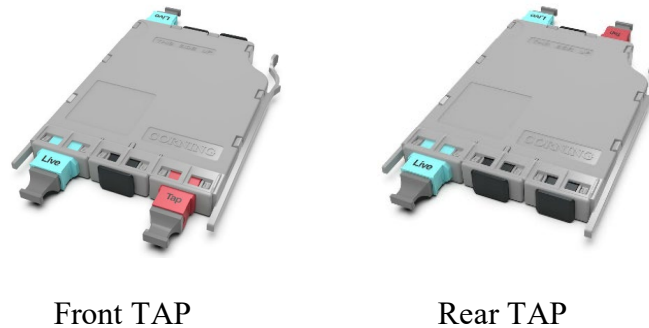

Tap Module System Design Configurations

There are different possible ways to design and integrate tap in a cable infrastructure system. When designing or implementing a cabling system that will support tap monitoring the following should be taken into consideration which are also basic considerations for Infrastructure designs.

Manageability – The ability to manage the monitoring of an infrastructure without disrupting the network to ensure improved troubleshooting and reconfiguration of ports during Moves, Adds and Changes (MACs). This is achieved by using the Integrated tap module component as part of the structured cabling system. The use of the Non-integrated tap will often require network disruption during network reconfiguration and MACs.

Scalability – A structured cabling solution based on a MTP cabling solution will enable the infrastructure to support both serial duplex transmission and high data rate parallel transmission speeds. The Configuration B and C tap modules enable scalability with the MTP LIVE and MTP TAP port capability. The Tap split ratio and placement of the Tap in the network will affect the distance reach of the network. The reach of the network decreases with increasing data rate speeds. The tap module can be placed anywhere in the different spaces of the network – MDA, HDA and EDA. However, placing the tap at the central point of the network, e.g. MDA, will ensure optimal distance reach while also enabling equipment interconnection and cross-connection to the different equipment spaces.

Flexibility - The modular nature of the tap module enables flexibility in design. Configuration A tap modules can be used to tap both structured and non-structure systems. With the MTP ports on the Configuration B and C tap modules, they can be integrated into a structured cabling system or integrated into a non-structured cable system via equipment port replication using MTP/LC harness.

Tap Module Cabling Scenarios

Configuration A – Non-integrated LC/LC/LC

This is deployed to monitor an existing cabling system, structured or unstructured, in support of serial duplex transmission protocol. It can be used when only a few ports are being tapped or for temporary monitoring purposes. The tap module sits outside of the cabling system in a separate housing if no module space is available, or a disparate product solution housing is being used. The near end equipment is interconnected to the input LIVE port of the tap module and the output LIVE port is then cross-connected to the far end equipment via the cabling system with the appropriate duplex jumpers. The TAP port is interconnected to the monitor equipment via duplex jumpers with the monitor end in simplex connector style, connected to two receive ports on the monitor device. Refer to the cabling solution shown in Figure 4.

Figure 4: Non-Integrated LC/LC/LC Tap Module Deployment

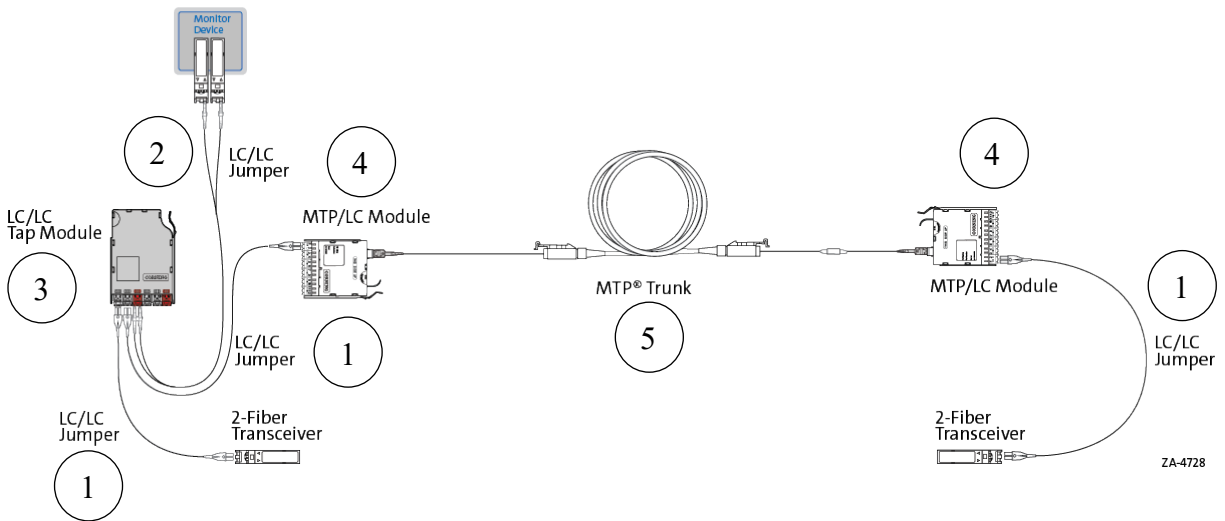

Bill of Materials for Figure 4 – EDGE (Base 12)

| Item | OM4 Part Number | OS2 Part Number | Description |
|------|------------------|------------------|--|
| 1 | 797902QD120xxxF | 787802GD120xxxF | 2F LC Uniboot Jumper; xxx feet |
| 2 | 030502Q5120xxxF | 020402G5120xxxF | Fiber Optic Patch Cord, 2 Fibers, LC Simplex to LC Duplex, Zipcord Tight-Buffered Cable, Riser, with 2.0 mm legs, xxx feet |
| 3 | ETM-5A-Q | ETM-5A-G | EDGE™ Tap Module, 50/50 split ratio (live/tap), 12F, four standard LC duplex adapters and two red LC duplex adapters at the front of the module, enables monitoring of two ports |
| 4 | ECM-UM12-05-93Q | ECM-UM12-04-89G | EDGE 12F MTP/LC Connector Module |
| 5 | G757548QPNDUxxxF | G909048GPNDUxxxF | 48-fiber MTP (non-pinned) to MTP (non-pinned) Trunk; xxx feet (Note: Trunks available in fiber counts up to 576F) |

| Bill of Materials for Figure 4 – EDGE8 (Base 8) | | | |
|---|----------------------|----------------------|---|
| Item | OM4 Part Number | OS2 Part Number | Description |
| 1 | 797902QD120xxxF | 787802GD120xxxF | 2F LC Uniboot Jumper; xxx feet |
| 2 | 030502Q5120xxxF | 020402G5120xxxF | Fiber Optic Patch Cord, 2 Fibers, LC Simplex to LC Duplex, Zipcord Tight-Buffered Cable, Riser, with 2.0 mm legs, xxx feet |
| 3 | ETM8-50A-Q | ETM8-50A-G | EDGE8® Tap Module, 50/50 split ratio (live/tap), 6F, two LC duplex adapters and one red LC duplex adapters at the front of the module, enables monitoring of one port |
| 4 | ECM8-UM08-05-E6Q-ULL | ECM8-UM08-04-E8G-ULL | EDGE8® Solutions Module, LC Duplex to MTP (non-pinned), 8 Fiber, Universal Polarity |
| 5 | GE5E548QPNDUxxxF | GE7E748GPNDUxxxF | EDGE8® MTP® Trunk, 48 Fibers, MTP 8F (Pinned) to MTP 8F(Pinned), TIA-568 Standard Universal Type-B Polarity, Pulling grip on first end only, xxx F, Non-Armored |

Configuration A – Non-integrated LC/LC/LC – BiDi

This is deployed to monitor an existing cabling system, structured or unstructured, in support of 40G BiDi transmission protocol. BiDi tap module splits each of the Bi-Directional (BiDi) wavelength signal lanes into two, at the different wavelengths, and are routed to the respective wavelength LIVE and TAP ports. Just like the non-integrated tap module, the BiDi tap modules sit outside of the cabling system in a separate housing if no module space is available, or a disparate product solution housing is being used. The near end equipment is interconnected to the input LIVE port of the Tap module and the output LIVE port cross-connected to the far end equipment via the cabling system with the appropriate duplex jumpers. The four splits receive wavelength TAP ports are interconnected to the monitor equipment via two duplex jumpers with the monitor ends in simplex connector style, connected to four receive ports on the monitor device. Refer to the cabling diagram shown in Figure 5.

Figure 5: Non-integrated LC/LC/LC BiDiTap Module Deployment

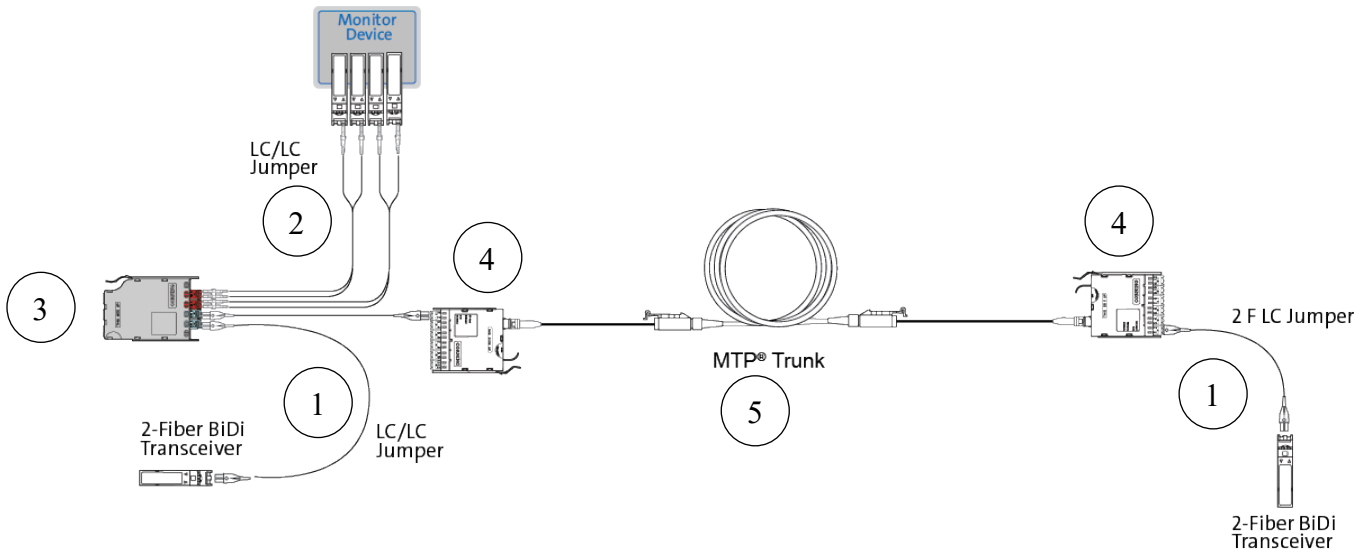

ZA-4736

| Bill of Materials for Figure 5 – EDGE (Base 12) | | | |
|---|-------------------|-----------------|---|
| Item | OM4 Part Number | OS2 Part Number | Description |
| 1 | 797902QD120xxxF | NA | 2F LC Uniboot Jumper; xxx feet |
| 2 | 030502Q5120xxxF | NA | Fiber Optic Patch Cord, 2 Fibers, LC Simplex to LC Duplex, Zipcord Tight-Buffered Cable, Riser, with 2.0 mm legs, xxx feet |
| 3 | ETM-5A-Q-BD | NA | EDGE™ Bidirectional Tap Module, 50 μm MM (OM4), 50/50 split ratio (live/tap), two red LC duplex adapters labeled TAP, two aqua LC duplex adapters labeled LIVE, supports Cisco's Bi-directional transceivers only |
| 4 | ECM-UM12-05-93Q | NA | EDGE 12F MTP/LC Connector Module |
| 5 | G757548QPNDDUxxxF | NA | 48-fiber MTP (non-pinned) to MTP (non-pinned) Trunk; xxx feet (Note: Trunks available in fiber counts up to 576F) |

| Bill of Materials for Figure 5 - EDGE8 (Base 8) | | | |
|---|----------------------|-----------------|--|
| Item | OM4 Part Number | OS2 Part Number | Description |
| 1 | 797902QD120xxxF | NA | 2F LC Uniboot Jumper; xxx feet |
| 2 | 030502Q5120xxxF | NA | Fiber Optic Patch Cord, 2 Fibers, LC Simplex to LC Duplex, Zipcord Tight-Buffered Cable, Riser, with 2.0 mm legs, xxx feet |
| 3 | ETM8-50A-Q-BD | NA | EDGE8® Bidirectional Tap Module, 50 µm MM (OM4), 50/50 split ratio (live/tap), two red LC duplex adapters labeled TAP, two aqua LC duplex adapters labeled LIVE, supports Cisco's Bi-directional transceivers only |
| 4 | ECM8-UM08-05-E6Q-ULL | NA | EDGE8® Solutions Module, LC Duplex to MTP (non-pinned), 8 Fiber, Universal Polarity |
| 5 | GE5E548QPNDUxxxF | NA | EDGE8® MTP® Trunk, 48 Fibers, MTP 8F (Pinned) to MTP 8F(Pinned), TIA-568 Standard Universal Type-B Polarity, Pulling grip on first end only, xxx F, Non-Armored |

Configuration A – Non-integrated LC/LC/LC – DeMux Tap

This is deployed to monitor an existing cabling system, structured or unstructured, in support of Wave Division Multiplexing (WDM) signals such as 40G LR4 where the monitoring device is 10G. DeMux tap is deployed when there is no WDM capable monitor device, necessitating the need to breakout and monitor the different multiplexed signals on different monitor receive ports. In the DeMux Tap module, the four different wavelength signal channels on the transmit fibers are each filtered out and routed to the receive TAP ports on the module in four LC duplex port representation. Like non-integrated tap, the DeMux tap modules sit outside of the cabling system in a separate housing if no module space is available, or a disparate product solution housing is being used. The near end equipment is interconnected to the input LIVE port on the Tap module and the output LIVE port is then cross-connected to the far end equipment via the cabling system with the appropriate duplex jumpers. The four receive Tap ports are interconnected to the monitor equipment via four duplex jumpers with the monitor ends of the jumper in simplex connector style, connecting eight receive ports on the monitor equipment. Refer to the cabling diagram shown in Figure 6.

Figure 6: Non-integrated LC/LC/LC – DeMux Tap

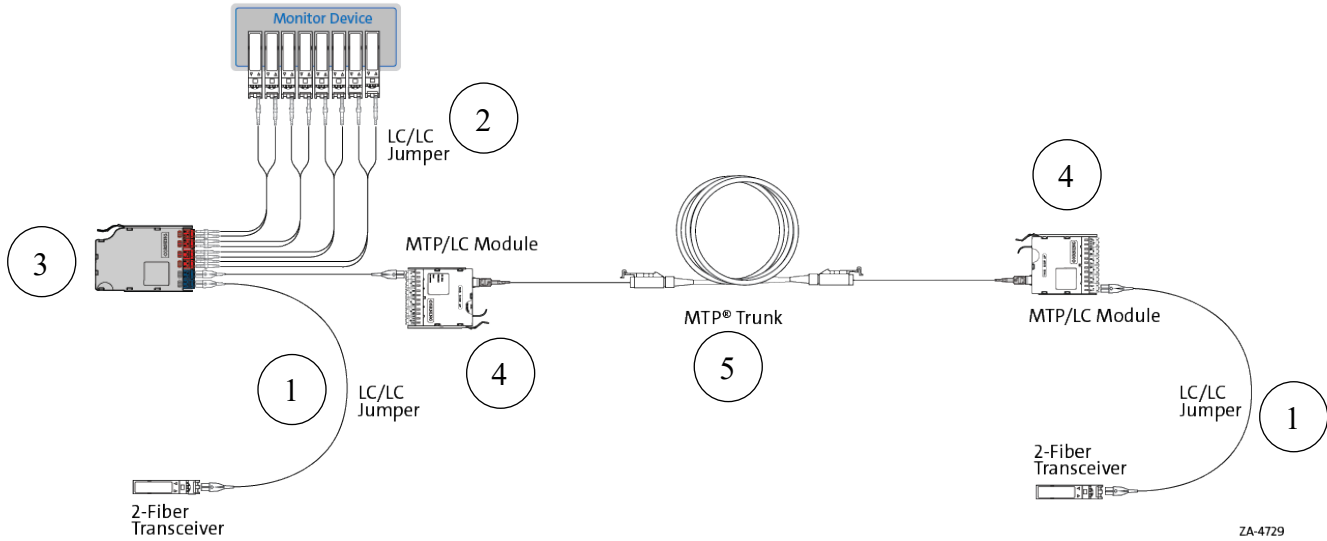

ZA-4729

| Bill of Materials for Figure 6 – EDGE (Base 12) | | | |
|---|-----------------|------------------|---|
| Item | OM4 Part Number | OS2 Part Number | Description |
| 1 | NA | 787802GD120xxxF | 2F LC Uniboot Jumper; xxx feet |
| 2 | NA | 020402G5120xxxF | Fiber Optic Patch Cord, 2 Fibers, LC Simplex to LC Duplex, Zipcord Tight-Buffered Cable, Riser, with 2.0 mm legs, xxx feet |
| 3 | NA | ETM-5A-G-DMX | EDGE™ LR4 Tap Module, 50/50 split ratio (live/tap), four red LC duplex adapters for TAP, two blue LC duplex adapters for LIVE, enables monitoring of one port. Supports LR4 I transceivers only |
| 4 | NA | ECM-UM12-04-89G | EDGE 12f MTP/LC Connector Module |
| 5 | NA | G909048GPNDUxxxF | 48-fiber MTP (non-pinned) to MTP (non-pinned) Trunk; xxx feet (Note: Trunks available in fiber counts up to 576F) |

Configuration B – Integrated MTP/MTP/LC

In this scenario, the MTP/MTP/LC tap module is deployed as a component part of the structured cabling to support serial duplex transmission. This deployment eliminates the use of extra rack space and maximizes the channel reach by reducing the number of loss components in the system. Within the infrastructure, the integrated tap module operates as a regular Corning Universal module with the addition of the MTP TAP port for monitoring. This allows the flexibility to monitor anytime without disrupting the network. Near-end equipment is connected to the module LIVE LC port via duplex jumpers and the far end equipment are connected through the rear LIVE MTP port across the structured cabling infrastructure. The MTP Tap port on the rear is interconnected to the monitor device via tap MTP/LC harness with the LC breakout in a simplex style to connect to the receive ports on the monitor device. Refer to the cabling diagram shown in Figure 7.

Figure 7: Integrated MTP/MTP/LC Tap module

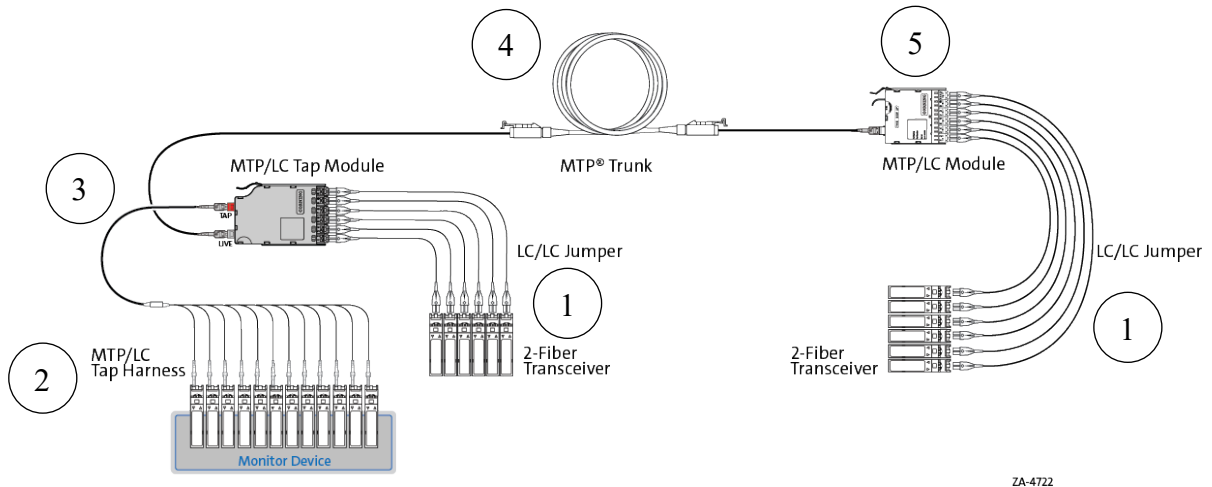

ZA-4722

Bill of Materials for Figure 7 – EDGE (Base 12)

| Item | OM4 Part Number | OS2 Part Number | Description |
|------|-------------------|-------------------|---|
| 1 | 797902QD120xxxF | 787802GD120xxxF | 2F LC Uniboot Jumper; xxx feet |
| 2 | H750312QE8-KWxxxF | H900212GE8-KWxxxF | EDGE™ Tap Harness, xxx F, Non-pinned MTP® PRO to LC Simplex |

CORNING

| | | | |
|---|------------------|------------------|---|
| 3 | ETM-5B-Q | ETM-5B-G | EDGE™ Tap Module, 50/50 split ratio (live/tap), 12F, 6 LC duplex ports, one pinned MTP® adapter labeled LIVE, one pinned red MTP adapter labeled TAP, enables six monitored ports, Universal Polarity |
| 4 | G757548QPNDUxxxF | G909048GPNDUxxxF | 48-fiber MTP (non-pinned) to MTP (non-pinned) Trunk; xxx feet (Note: Trunks available in fiber counts up to 576F) |
| 5 | ECM-UM12-05-93Q | ECM-UM12-04-89G | EDGE 12f MTP/LC Connector Module |

Bill of Materials for Figure 7 - EDGE8 (Base 8)

| Item | OM4 Part Number | OS2 Part Number | Description |
|------|----------------------|----------------------|--|
| 1 | 797902QD120xxxF | 787802GD120xxxF | 2F LC Uniboot Jumper; xxx feet |
| 2 | HE50308QPH-KBxxxF | HE70208GPH-KBxxxF | EDGE8® Tap Harness, xxx F, Pinned MTP® PRO to LC Simplex |
| 3 | ETM8-50B-Q | ETM8-50B-G | EDGE8® Tap Module, 50/50 split ratio (live/tap), 8F, 4 LC duplex ports, one non-pinned MTP® adapter labeled LIVE, one non-pinned red MTP adapter labeled TAP, enables four monitored ports, Universal Polarity |
| 4 | GE5E548QPNDUxxxF | GE7E748GPNDUxxxF | EDGE8® MTP® Trunk, 48 Fibers, MTP 8F (Pinned) to MTP 8F(Pinned), TIA-568 Standard Universal Type-B Polarity, Pulling grip on first end only, xxx F, Non-Armored |
| 5 | ECM8-UM08-05-E6Q-ULL | ECM8-UM08-04-E8G-ULL | EDGE8® Solutions Module, LC Duplex to MTP (non-pinned), 8 Fiber, Universal Polarity |

Configuration B – Integrated MTP/MTP/LC – Port Replication

The Integrated MTP/MTP/LC tap can also be used to port replicate a serial duplex switch. This enables the integration of tapping in an existing, or disparate structured or unstructured cabling link. The interconnection of the MTP LIVE port on the tap module and the duplex ports on the transceiver via an MTP/LC duplex harness replicates the equipment ports onto the module. Connection to far end equipment is completed with the use of cross-connect jumpers across the cabling system. The TAP port on the rear of the tap module allows for the flexibility to monitor anytime without disrupting the live network. Refer to the cabling diagram shown in Figure 8.

Figure 8: Integrated MTP/MTP/LC Tap module Port Replication

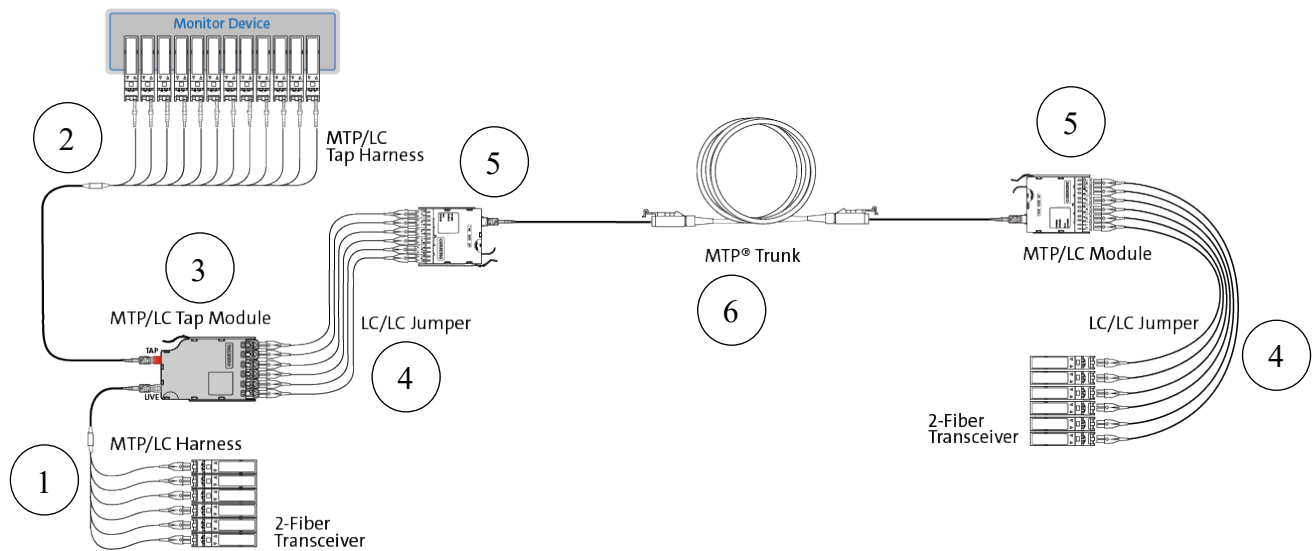

ZA-4723

Bill of Materials for Figure 8 – EDGE (Base 12)

| Item | OM4 Part Number | OS2 Part Number | Description |
|------|-------------------|-------------------|--|
| 1 | H757912QPH-KBxxxF | H907812GPH-KBxxxF | EDGE™ Non-staggered Harness, 12-fiber, MTP® PRO 12F (Non-pinned) to LC Uniboot, low-loss MM, TIA-568 Type-B Polarity, 24-inch legs (+3/-0 in), xxx F |
| 2 | H750312QE8-KWxxxF | H900212GE8-KWxxxF | EDGE™ Tap Harness, xxx F, Non-pinned MTP® PRO to LC Simplex |

CORNING

| | | | |
|---|------------------|------------------|---|
| 3 | ETM-5B-Q | ETM-5B-G | EDGE™ Tap Module, 50/50 split ratio (live/tap), 12F, 6 LC duplex ports, one pinned MTP® adapter labeled LIVE, one pinned red MTP adapter labeled TAP, enables six monitored ports, Universal Polarity |
| 4 | 797902QD120xxxF | 787802GD120xxxF | 2F LC Uniboot Jumper; xxx feet |
| 5 | ECM-UM12-05-93Q | ECM-UM12-04-89G | EDGE 12f MTP/LC Connector Module |
| 6 | G757548QPNDUxxxF | G909048GPNDUxxxF | 48-fiber MTP (non-pinned) to MTP (non-pinned) Trunk; xxx feet (Note: Trunks available in fiber counts up to 576F) |

Bill of Materials for Figure 8 - EDGE8 (Base 8)

| Item | OM4 Part Number | OS2 Part Number | Description |
|------|----------------------|----------------------|--|
| 1 | HE67908QPH-KBxxxF | HE87808GPH-KBxxxF | EDGE8® Non-staggered Harness, 8 fiber, MTP® PRO 8F (Non-pinned) to LC Uniboot SM, TIA-568 Type-B Polarity, 24-inch legs (+3/-0 in), xxx F |
| 2 | HE50308QPH-KBxxxF | HE70208GPH-KBxxxF | EDGE8® Tap Harness, xxx F, Pinned MTP® PRO to LC Simplex |
| 3 | ETM8-50B-Q | ETM8-50B-G | EDGE8® Tap Module, 50/50 split ratio (live/tap), 8F, 4 LC duplex ports, one non-pinned MTP® adapter labeled LIVE, one non-pinned red MTP adapter labeled TAP, enables four monitored ports, Universal Polarity |
| 4 | 797902QD120xxxF | 787802GD120xxxF | 2F LC Uniboot Jumper; xxx feet |
| 5 | ECM8-UM08-05-E6Q-ULL | ECM8-UM08-04-E8G-ULL | EDGE8® Solutions Module, LC Duplex to MTP (non-pinned), 8 Fiber, Universal Polarity |
| 6 | GE5E548QPNDUxxxF | GE7E748GPNDUxxxF | EDGE8® MTP® Trunk, 48 Fibers, MTP 8F (Pinned) to MTP 8F(Pinned), TIA-568 Standard Universal Type-B Polarity, Pulling grip on first end only, xxx F, Non-Armored |

Configuration B – Integrated MTP/MTP/LC – Remote Monitoring

This configuration is like the above Configuration B deployment, however the TAP port on the tap module is extended via structure cabling to a different location where the monitoring equipment resides. This can be deployed for security, compliance, access control or as part of a design requirement. At the the monitor equipment location, the structured cabling is terminated onto an MTP/LC module which is then interconnected to the monitor port via duplex jumper with the monitor port in simplex connector style. This configuration can only be deployed for Ethernet protocols. Fiber Channel protocols are limited by the amount of connector loss introduced by the structured cabling component. Refer to the cabling diagram shown in Figure 9

Figure 9: Integrated MTP/MTP/LC – Remote Monitoring

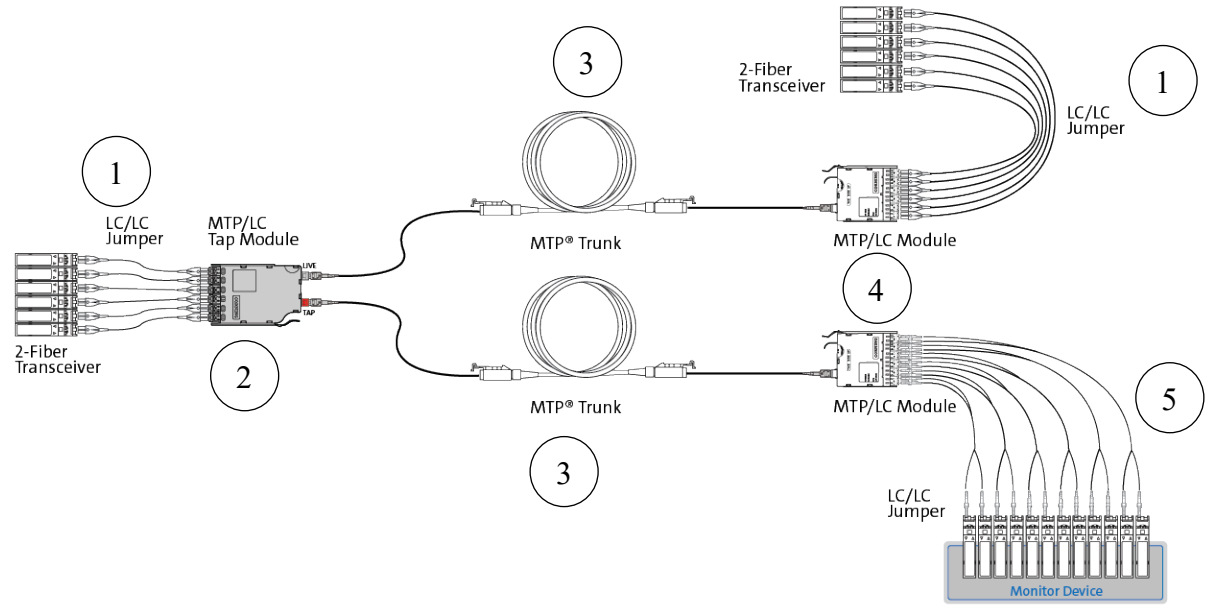

ZA-4724

| Bill of Materials for Figure 9 – EDGE (Base 12) | | | |
|---|-----------------|-----------------|---|
| Item | OM4 Part Number | OS2 Part Number | Description |
| 1 | 797902QD120xxxF | 787802GD120xxxF | 2F LC Uniboot Jumper; xxx feet |
| 2 | ETM-5B-Q | ETM-5B-G | EDGE™ Tap Module, 50/50 split ratio (live/tap), 12F, 6 LC duplex ports, one pinned MTP® adapter labeled LIVE, one pinned red MTP adapter labeled TAP, enables six monitored ports, Universal Polarity |



| | | | |
|---|------------------|------------------|--|
| 3 | G757548QPNDUxxxF | G909048GPNDUxxxF | 48-fiber MTP (non-pinned) to MTP (non-pinned) Trunk; xxx feet (Note: Trunks available in fiber counts up to 576F) |
| 4 | ECM-UM12-05-93Q | ECM-UM12-04-89G | EDGE 12F MTP/LC Connector Module |
| 5 | 030502Q5120xxxF | 020402G5120xxxF | Fiber Optic Patch Cord, 2 Fibers, LC Simplex to LC Duplex, Zipcord Tight-Buffered Cable, Riser, with 2.0 mm legs, xxx feet |

Bill of Materials for Figure 9 - EDGE8 (Base 8)

| Item | OM4 Part Number | OS2 Part Number | Description |
|------|----------------------|----------------------|---|
| 1 | 797902QD120xxxF | 787802GD120xxxF | 2F LC Uniboot Jumper; xxx feet |
| 2 | ETM8-50B-Q | ETM8-50B-G | EDGE8® Tap Module, 50/50 split ratio (live/tap), 8F LC duplex ports, one non-pinned MTP® adapter labeled LIVE, one non-pinned red MTP adapter labeled TAP, enables four monitored ports, Universal Polarity |
| 3 | GE5E548QPNDUxxxF | GE7E748GPNDUxxxF | EDGE8® MTP® Trunk, 48 Fibers, MTP 8F (Pinned) to MTP 8F(Pinned), TIA-568 Standard Universal Type-B Polarity, Pulling grip on first end only, xxx F, Non-Armored |
| 4 | ECM8-UM08-05-E6Q-ULL | ECM8-UM08-04-E8G-ULL | EDGE8® Solutions Module, LC Duplex to MTP (non-pinned), 8 Fiber, Universal Polarity |
| 5 | 030502Q5120xxxF | 020402G5120xxxF | Fiber Optic Patch Cord, 2 Fibers, LC Simplex to LC Duplex, Zipcord Tight-Buffered Cable, Riser, with 2.0 mm legs, xxx feet |

Configuration B – Integrated MTP/MTP/LC – BiDi

Unlike the regular integrated tap module, BiDi Integrated tap module has two MTP TAP ports. The Bi-Directional channels at the different wavelengths from each Live MTP link is filtered out and routed to the two MTP Tap ports. Within the cabling infrastructure, the integrated BiDi tap module operates as a regular Corning Universal module with the addition of the two TAP MTP ports for monitoring. This allows for the flexibility to monitor anytime without disrupting the live network. As illustrated in the diagram in Figure 10, near-end equipment is connected to the module LIVE LC port via duplex jumpers, and the far end equipment is connected through the rear LIVE MTP port across the structured cabling infrastructure. The two MTP TAP ports on the rear is interconnected to the monitor device via two tap MTP/LC harnesses with the LC breakout in a simplex configuration, to connect to the receive ports on the monitor device.

Figure 10: Integrated MTP/MTP/LC – BiDi Tap Module

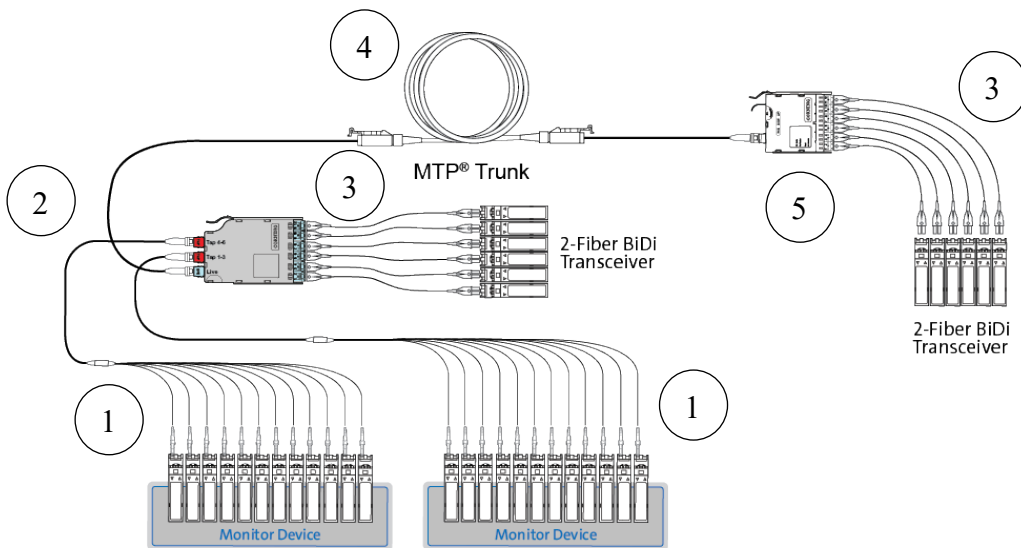

ZA-4737

Bill of Materials for Figure 10 – EDGE (Base 12)

| Item | OM4 Part Number | OS2 Part Number | Description |
|------|-------------------|-----------------|--|
| 1 | H750312QE8-KWxxxF | NA | EDGE™ Tap Harness, xxx F, Non-pinned MTP® PRO to LCUPC Simplex |

CORNING

| | | | |
|---|------------------|----|--|
| 2 | ETM-5B-Q-BD | NA | EDGE™ Bidirectional Tap Module, 50 µm MM (OM4), 50/50 split ratio (live/tap), 12F, 6 LC duplex ports, one pinned MTP® adapter labeled LIVE, one pinned red MTP adapter labeled TAP, enables six monitored ports, Universal Polarity, supports Cisco's Bi-directional |
| 3 | 797902QD120xxxF | NA | 2F LC Uniboot Jumper; xxx feet |
| 4 | G757548QPNDUxxxF | NA | 48-fiber MTP (non-pinned) to MTP (non-pinned) Trunk; xxx feet (Note: Trunks available in fiber counts up to 576F) |
| 5 | ECM-UM12-05-93Q | NA | EDGE 12F MTP/LC Connector Module |

Configuration C – Integrated MTP/MTP/MTP - Duplex Links

In this scenario, the MTP/MTP/MTP tap module is deployed as a component of the structured cabling in support of serial duplex transmission protocol. It can also, be used to future proof the infrastructure for easy migration to higher parallel transmission data rate without the need to swap out MTP/LC modules in the infrastructure. This deployment eliminates the use of extra rack space and maximizes the channel reach by reducing the number of loss components in the system. For duplex transmission, near-end equipment is connected to the LIVE MTP port in front of the module via MTP/LC harness and the far end equipment is connected through the rear LIVE MTP port across the structured cabling infrastructure. The MTP Tap port is interconnected to the monitor device via tap MTP/LC harness with the LC breakout in a simplex configuration, to connect to the receive ports on the monitor device. Refer to the cabling diagram shown in Figure 11.

Figure 11: Integrated MTP/MTP/MTP - Duplex Links

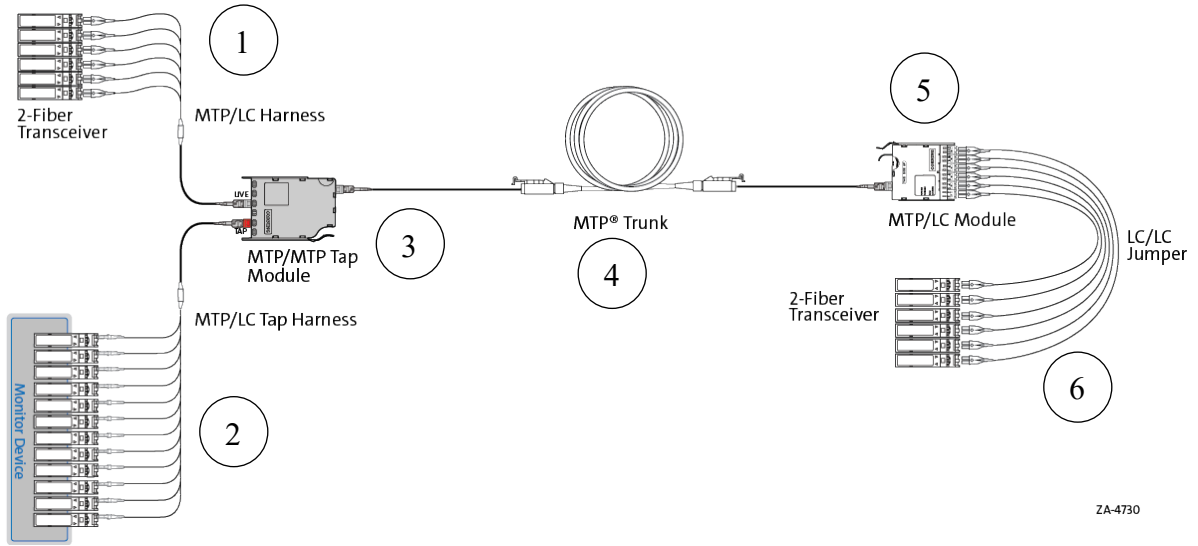

ZA-4730

Bill of Materials for Figure 11 – EDGE (Base 12)

| Item | OM4 Part Number | OS2 Part Number | Description |
|------|-------------------|-------------------|--|
| 1 | H757912QPH-KBxxxF | H907812GPH-KBxxxF | EDGE™ Non-staggered Harness, 12-fiber, MTP® PRO 12F (Non-pinned) to LC Uniboot, low-loss MM, TIA-568 Type-B Polarity, 24-inch legs (+3/-0 in), xxx F |
| 2 | H750312QE8-KWxxxF | H900212GE8-KWxxxF | EDGE™ Tap Harness, xxx F, Non-pinned MTP® PRO to LC Simplex |
| 3 | ETM-5C-Q | ETM-5C-G | EDGE™ Tap Module, 50/50 split ratio (live/tap), one front-mounted pinned red MTP® adapter labeled TAP, two pinned MTP adapters labeled LIVE, enables six monitored ports |
| 4 | G757548QPNDUxxxF | G909048GPNDUxxxF | 48-fiber MTP (non-pinned) to MTP (non-pinned) Trunk; xxx feet (Note: Trunks available in fiber counts up to 576F) |
| 5 | ECM-UM12-05-93Q | ECM-UM12-04-89G | EDGE 12F MTP/LC Connector Module |
| 6 | 797902QD120xxxF | 787802GD120xxxF | 2F LC Uniboot Jumper; xxx feet |

CORNING

| Bill of Materials for Figure 11 - EDGE8 (Base 8) | | | |
|--|----------------------|----------------------|---|
| Item | OM4 Part Number | OS2 Part Number | Description |
| 1 | HE67908QPH-KBxxxF | HE87808GPH-KBxxxF | EDGE8® Non-staggered Harness, 8 fiber, MTP® PRO 8F (Non-pinned) to LC Uniboot SM, TIA-568 Type-B Polarity, 24-inch legs (+3/-0 in), xxx F |
| 2 | HE50308QPH-KBxxxF | HE70208GPH-KBxxxF | EDGE8® Tap Harness, xxxF, Pinned MTP® PRO to LC Simplex |
| 3 | ETM8-50C-Q | ETM8-50C-G | EDGE8® Tap Module, 50/50 split ratio (live/tap), non-pinned Tap (red) and pinned Live MTP adapters on the front, non-pinned Live MTP adapter on the rear |
| 4 | GE5E548QPNDUxxxF | GE7E748GPNDUxxxF | EDGE8® MTP® Trunk, 48 Fibers, MTP 8F (Pinned) to MTP 8F(Pinned), TIA-568 Standard Universal Type-B Polarity, Pulling grip on first end only, xxx F, Non-Armored |
| 5 | ECM8-UM08-05-E6Q-Ull | ECM8-UM08-04-E8G-Ull | EDGE8® Solutions Module, LC Duplex to MTP (non-pinned), 8 Fiber, Universal Polarity |
| 6 | 797902QD120xxxF | 787802GD120xxxF | 2F LC Uniboot Jumper; xxx feet |

Configuration C – Integrated MTP/MTP/MTP – Duplex Links with Remote Monitoring

The next configuration represents a network where the monitor device is in a different location than the (MDA) location. The MTP TAP port on the rear of the Tap module is extended via structured cabling to the monitor location. At the remote location, the structured cabling is terminated onto a MTP/LC module, and the monitor devices are inter-connected via duplex jumpers with the monitor connector end in a simplex configuration. Refer to the cabling diagram shown in Figure 12.

Figure 12: Integrated MTP/MTP/MTP – Duplex Links with Remote Monitoring

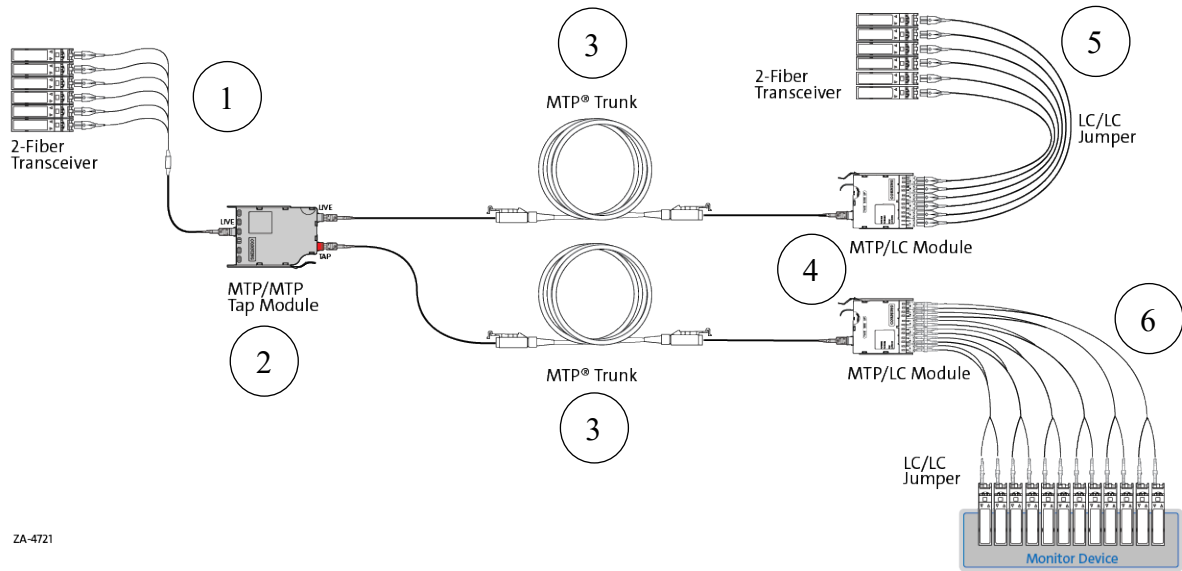

ZA-4721

| Bill of Materials for Figure 12 – EDGE (Base 12) | | | |
|--|-------------------|-------------------|---|
| Item | OM4 Part Number | OS2 Part Number | Description |
| 1 | H757912QPH-KBxxxF | H907812GPH-KBxxxF | EDGE™ Non-staggered Harness, 12-fiber, MTP® PRO 12F (Non-pinned) to LC Uniboot, low-loss MM, TIA-568 Type-B Polarity, 24-inch legs (+3/-0 in), xxx F |
| 2 | ETM-5C-Q-R | ETM-5C-G-R | EDGE™ Tap Module, 50/50 split ratio (live/tap), one rear-mounted pinned red MTP® adapter labeled TAP, two pinned MTP adapters labeled LIVE, enables six monitored ports |
| 3 | G757548QPNDUxxxF | G909048GPNDUxxxF | 48-fiber MTP (non-pinned) to MTP (non-pinned) Trunk; xxx feet (Note: Trunks available in fiber counts up to 576F) |
| 4 | ECM-UM12-05-93Q | ECM-UM12-04-89G | EDGE 12F MTP/LC Connector Module |
| 5 | 797902QD120xxxF | 787802GD120xxxF | 2F LC Uniboot Jumper; xxx feet |

| | | | |
|---|-----------------|-----------------|--|
| 6 | 030502Q5120xxxF | 020402G5120xxxF | Fiber Optic Patch Cord, 2 Fibers, LC Simplex to LC Duplex, Zipcord Tight-Buffered Cable, Riser, with 2.0 mm legs, xxx feet |
|---|-----------------|-----------------|--|

| Bill of Materials for Figure 12 - EDGE8 (Base 8) | | | |
|--|----------------------|----------------------|---|
| Item | OM4 Part Number | OS2 Part Number | Description |
| 1 | HE67908QPH-KBxxxF | HE87808GPH-KBxxxF | EDGE8® Non-staggered Harness, 8 fiber, MTP® PRO 8F (Non-pinned) to LC Uniboot SM, TIA-568 Type-B Polarity, 24-inch legs (+3/-0 in), xxx F |
| 2 | ETM8-50C-Q-R | ETM8-50C-G-R | EDGE8® Tap Module, 50/50 split ratio (live/tap), pinned Live MTP adapter on the front of the module and non-pinned Live and Tap (red) MTP adapters on the rear |
| 3 | GE5E548QPNDDUxxxF | GE7E748GPNDDUxxxF | EDGE8® MTP® Trunk, 48 Fibers, MTP 8F (Pinned) to MTP 8F(Pinned), TIA-568 Standard Universal Type-B Polarity, Pulling grip on first end only, xxx F, Non-Armored |
| 4 | ECM8-UM08-05-E6Q-ULL | ECM8-UM08-04-E8G-ULL | EDGE8® Solutions Module, LC Duplex to MTP (non-pinned), 8 Fiber, Universal Polarity |
| 5 | 797902QD120xxxF | 787802GD120xxxF | 2F LC Uniboot Jumper; xxx feet |
| 6 | 030502Q5120xxxF | 020402G5120xxxF | Fiber Optic Patch Cord, 2 Fibers, LC Simplex to LC Duplex, Zipcord Tight-Buffered Cable, Riser, with 2.0 mm legs, xxx feet |

Configuration C – Integrated MTP/MTP/MTP Tap Module – Parallel Links

When migrating from duplex transmission to higher data rate via parallel transmission such as 40G, MTP equipment connectivity is required. A MTP jumper is used to interconnect the MTP parallel link equipment port to the MTP LIVE port in front of the tap module. When the monitoring equipment is capable of receiving a parallel input, the front facing TAP port module is used to interconnect the monitor via MTP/MTP tap harness as shown in Figure 13.

CORNING

Figure 13: Integrated MTP/MTP/MTP – Parallel Links with Parallel Tapping

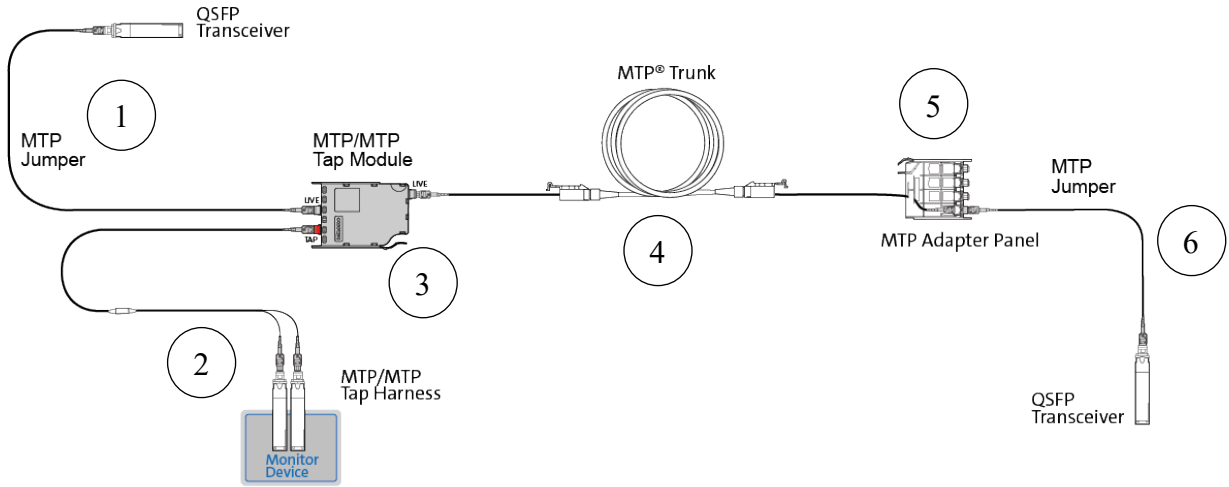

ZA-4738

| Bill of Materials for Figure 13 – EDGE (Base 12) | | | |
|--|-------------------|-------------------|---|
| Item | OM4 Part Number | OS2 Part Number | Description |
| 1 | J757512QE8-NBxxxF | J909012GE8-NBxxxF | 12-fiber MTP® Jumper, MTP® PRO (non-pinned) to MTP® PRO (non-pinned), TIA-568 Type-B polarity, no pulling grip, xxx F |
| 2 | HE6E608QPH-KHxxxF | HE8E808GPH-KHxxxF | EDGE8® Tap MTP® to MTP® Harness, xxx Feet, one 8-fiber non-pinned MTP to two 4 fiber non-pinned MTPs, Type-H polarity |
| 3 | ETM-5C-Q | ETM-5C-G | EDGE™ Tap Module, 50/50 split ratio (live/tap), one front-mounted pinned red MTP® adapter labeled TAP, two pinned MTP adapters labeled LIVE |
| 4 | G757548QPNDUxxxF | G909048GPNDUxxxF | 48-fiber MTP (non-pinned) to MTP (non-pinned) Trunk; xxx feet (Note: Trunks available in fiber counts up to 576F) |
| 5 | EDGE-CP48-E3 | EDGE-CP48-90 | EDGE™ 48-fiber MTP Connector Panel |

| | | | |
|---|-------------------|-------------------|---|
| 6 | J759312QE8-NAxxxF | J899012GE8-NAxxxF | 12-fiber MTP® Jumper, MTP® PRO (pinned) to MTP® PRO (non-pinned), TIA-568 Type-A polarity, no pulling grip, xxx F |
|---|-------------------|-------------------|---|

| Bill of Materials for Figure 13 - EDGE8 (Base 8) | | | |
|--|-------------------|-------------------|---|
| Item | OM4 Part Number | OS2 Part Number | Description |
| 1 | JE6E608QE8-NBxxxF | JE8E808GE8-NBxxxF | 8-fiber MTP® PRO Jumper, MTP® PRO 8F (non-pinned) to MTP® PRO 8F (non-pinned), TIA-568 Type-B Polarity, no pulling grip, xxx F |
| 2 | HE5E608QPH-KHxxxF | HE7E808GPH-KHxxxF | EDGE8® Tap MTP® PRO to MTP® PRO Harness, xxx Feet, one 8-fiber pinned MTP to two 4-fiber non-pinned MTPs, Type-H polarity |
| 3 | ETM8-50C-Q | ETM8-50C-G | EDGE8® Tap Module, 50/50 split ratio (live/tap), non-pinned Tap (red) and pinned Live MTP adapters on the front, non-pinned Live MTP adapter on the rear |
| 4 | GE5E548QPNDDUxxxF | GE7E748GPNDDUxxxF | EDGE8® MTP® Trunk, 48 Fibers, MTP 8F (Pinned) to MTP 8F(Pinned), TIA-568 Standard Universal Type-B Polarity, Pulling grip on first end only, xxx F, Non-Armored |
| 5 | EDGE8-CP32-V3 | EDGE8-CP32-V1 | EDGE8® 32-fiber MTP Connector Panel |
| 6 | JE6E608QE8-NAxxxF | JE8E808GE8-NAxxxF | 8-fiber MTP® PRO Jumper, MTP® PRO 8F (non-pinned) to MTP® PRO 8F (non-pinned), TIA-568 Type-A Polarity, no pulling grip, xxx F |

For situations where the monitoring equipment does not have parallel monitoring capability, a MTP/LC harness is utilized for the TAP connection. Refer to the cabling diagram shown in Figure 14.

Figure 14: Integrated MTP/MTP/MTP Tap Module – Parallel Links

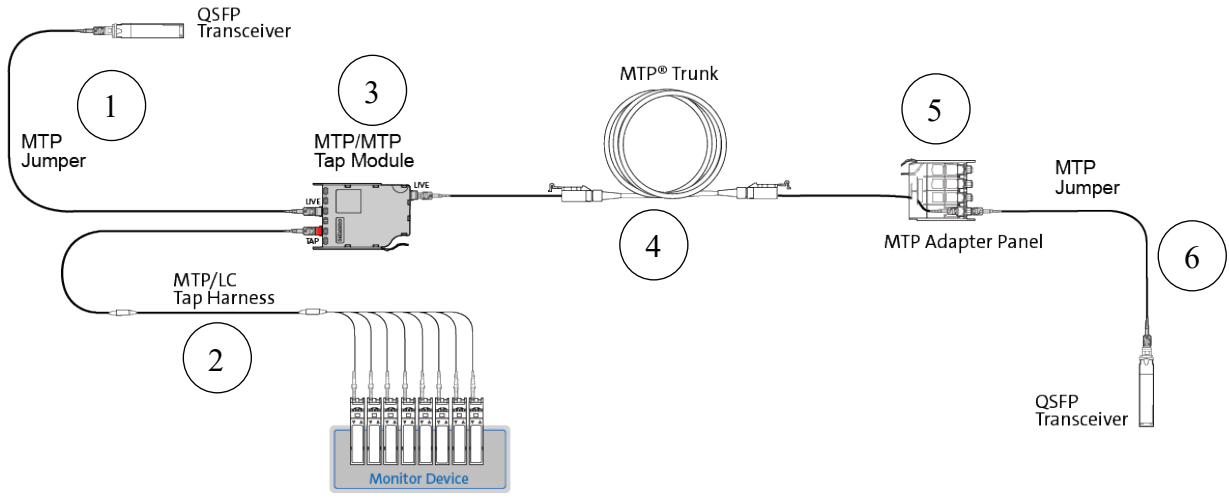

ZA-4727

| Bill of Materials for Figure 14 – EDGE (Base 12) | | | |
|--|-------------------|-------------------|--|
| Item | OM4 Part Number | OS2 Part Number | Description |
| 1 | J757512QE8-NBxxxF | J909012GE8-NBxxxF | 12-fiber MTP® Jumper, MTP® PRO (non-pinned) to MTP® PRO (non-pinned), TIA-568 Type-B polarity, no pulling grip, xxx F |
| 2 | HE60308QPH-KBxxxF | HE80208GPH-KBxxxF | EDGE8® Tap Harness, xxxF, Non-Pinned MTP PRO to LC Simplex |
| 3 | ETM-5C-Q | ETM-5C-G | EDGE™ Tap Module, 50/50 split ratio (live/tap), one front-mounted pinned red MTP® adapter labeled TAP, two pinned MTP adapters labeled LIVE, enables six monitored ports |
| 4 | G757548QPNDUxxxF | G909048GPNDUxxxF | 48-fiber MTP (non-pinned) to MTP (non-pinned) Trunk; xxx feet (Note: Trunks available in fiber counts up to 576F) |
| 5 | EDGE-CP48-E3 | EDGE-CP48-90 | EDGE™ 48-fiber MTP Connector Panel |

| | | | |
|---|-------------------|-------------------|---|
| 6 | J759312QE8-NAxxxF | J899012GE8-NAxxxF | 12-fiber MTP® Jumper, MTP® PRO (pinned) to MTP® PRO (non-pinned), TIA-568 Type-A polarity, no pulling grip, xxx F |
|---|-------------------|-------------------|---|

Bill of Materials for Figure 14 - EDGE8 (Base 8)

| Item | OM4 Part Number | OS2 Part Number | Description |
|------|-------------------|-------------------|---|
| 1 | JE6E608QE8-NBxxxF | JE8E808GE8-NBxxxF | 8-fiber MTP® PRO Jumper, MTP PRO 8F (non-pinned) to MTP PRO 8F (non-pinned), TIA-568 Type-B Polarity, no pulling grip, xxx F |
| 2 | HE50308QPH-KBxxxF | HE70208GPH-KBxxxF | EDGE8® Tap Harness, xxxF, Pinned MTP PRO to LC Simplex |
| 3 | ETM8-50C-Q | ETM8-50C-G | EDGE8 Tap Module, 50/50 split ratio (live/tap), non-pinned Tap (red) and pinned Live MTP adapters on the front, non-pinned Live MTP adapter on the rear |
| 4 | GE5E548QPNDUxxxF | GE7E748GPNDUxxxF | EDGE8 MTP Trunk, 48 Fibers, MTP 8F (Pinned) to MTP 8F(Pinned), TIA-568 Standard Universal Type-B Polarity, Pulling grip on first end only, xxx F, Non-Armored |
| 5 | EDGE8-CP32-V3 | EDGE8-CP32-V1 | EDGE8 32-fiber MTP Connector Panel |
| 6 | JE6E608QE8-NAxxxF | JE8E808GE8-NAxxxF | 8-fiber MTP PRO Jumper, MTP PRO 8F (non-pinned) to MTP PRO 8F (non-pinned), TIA-568 Type-A Polarity, no pulling grip, xxx F |

Configuration C.3 – Integrated MTP/MTP/MTP – Parallel links with Remote Monitoring

In a situation where the monitoring device is in a different location from the main distribution location (MDA), a rear-facing MTP TAP port tap module can be extended via structured cabling to the monitor location. At the monitor location, when the monitoring equipment is capable of receiving a parallel input, the monitor ports are interconnected to the structured cable via MTP/MTP Tap harness as shown in figure 15.

Figure 15: Integrated MTP/MTP/MTP – Parallel Links with Remote MTP port Monitor Device

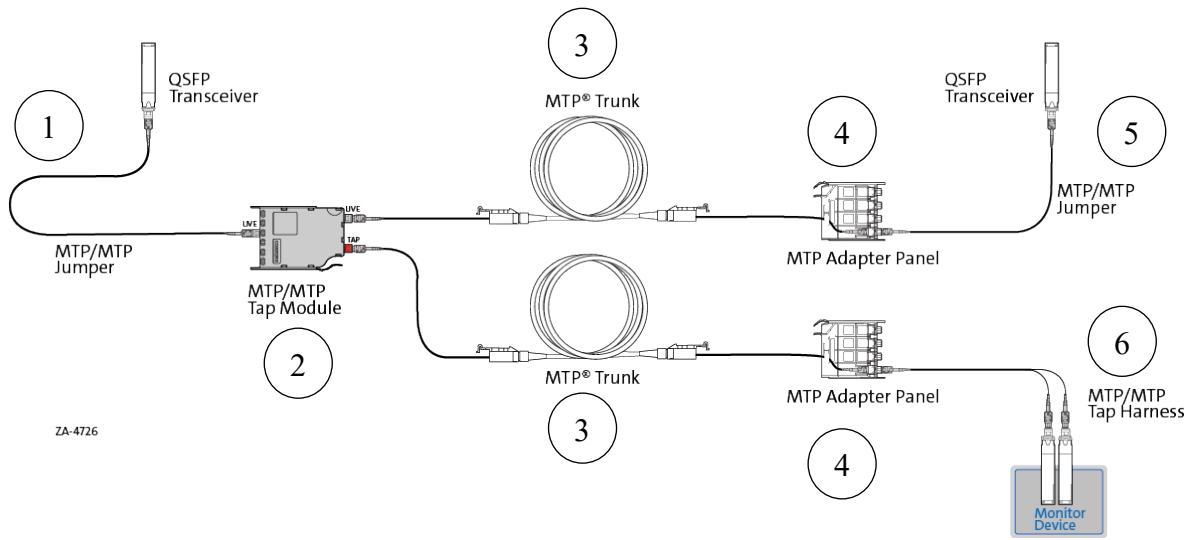

| Bill of Materials for Figure 15 – EDGE (Base 12) | | | |
|--|-------------------|-------------------|--|
| Item | OM4 Part Number | OS2 Part Number | Description |
| 1 | J757512QE8-NBxxxF | J909012GE8-NBxxxF | 12-fiber MTP® Jumper, MTP® PRO (non-pinned) to MTP® PRO (non-pinned), TIA-568 Type-B polarity, no pulling grip, xxx F |
| 2 | ETM-5C-Q-R | ETM-5C-G-R | EDGE™ Tap Module, 50/50 split ratio (live/tap), one rear-mounted pinned red MTP® adapter labeled TAP, two pinned MTP adapters labeled LIVE |
| 3 | G757548QPNDUxxxF | G909048GPNDUxxxF | 48-fiber MTP (non-pinned) to MTP (non-pinned) Trunk; xxx feet (Note: Trunks available in fiber counts up to 576F) |
| 4 | EDGE-CP48-E3 | EDGE-CP48-90 | EDGE™ 48-fiber MTP Connector Panel |
| 5 | J759312QE8-NAxxxF | J899012GE8-NAxxxF | 12-fiber MTP® Jumper, MTP® PRO (pinned) to MTP® PRO (non-pinned), TIA-568 Type-A polarity, no pulling grip, xxx F |

| | | | |
|---|-------------------|-------------------|---|
| 6 | HE5E608QPH-KHxxxF | HE7E808GPH-KHxxxF | EDGE8® Tap MTP® to MTP® Harness, xxx Feet, one 8-fiber pinned MTP to two 4 fiber non-pinned MTPs, Type-H polarity |
|---|-------------------|-------------------|---|

Bill of Materials for Figure 15 - EDGE8 (Base 8)

| Item | OM4 Part Number | OS2 Part Number | Description |
|------|-------------------|-------------------|---|
| 1 | JE6E608QE8-NBxxxF | JE8E808GE8-NBxxxF | 8-fiber MTP® PRO Jumper, MTP® PRO 8F (non-pinned) to MTP® PRO 8F (non-pinned), TIA-568 Type-B Polarity, no pulling grip, xxx F |
| 2 | ETM8-50C-Q-R | ETM8-50C-G-R | EDGE8® Tap Module, 50/50 split ratio (live/tap), pinned Live MTP adapter on the front of the module and non-pinned Live and Tap (red) MTP adapters on the rear |
| 3 | GE5E548QPNDUxxxF | GE7E748GPNDUxxxF | EDGE8® MTP® Trunk, 48 Fibers, MTP 8F (Pinned) to MTP 8F(Pinned), TIA-568 Standard Universal Type-B Polarity, Pulling grip on first end only, xxx F, Non-Armored |
| 4 | EDGE8-CP32-V3 | EDGE8-CP32-V1 | EDGE8® 32-fiber MTP Connector Panel |
| 5 | JE6E608QE8-NAxxxF | JE8E808GE8-NAxxxF | 8-fiber MTP® PRO Jumper, MTP® PRO 8F (non-pinned) to MTP® PRO 8F (non-pinned), TIA-568 Type-A Polarity, no pulling grip, xxx F |
| 6 | HE5E608QPH-KHxxxF | HE7E808GPH-KHxxxF | EDGE8® Tap MTP® PRO to MTP® PRO Harness, xxx Feet, one 8 fiber pinned MTP to two 4 fiber non-pinned MTPs, Type-H polarity |

For situations where the monitoring equipment does not have parallel optic receiver monitoring capability, a tap MTP/ LC breakout is used to interconnect the structured cable to the monitor port as shown in Figure 16.

Figure 16: Integrated MTP/MTP/MTP – Parallel Links with Remote LC port Monitor Device

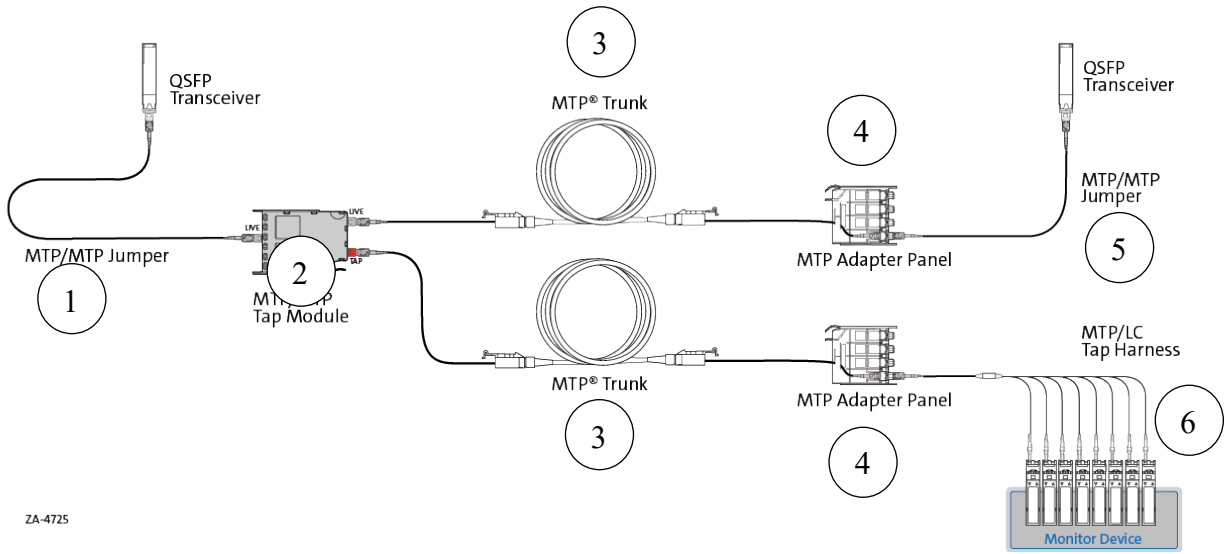

Bill of Materials for Figure 16 – EDGE (Base 12)

| Item | OM4 Part Number | OS2 Part Number | Description |
|------|-------------------|-------------------|---|
| 1 | J757512QE8-NBxxxF | J909012GE8-NBxxxF | 12-fiber MTP® Jumper, MTP® PRO (non-pinned) to MTP® PRO (non-pinned), TIA-568 Type-B polarity, no pulling grip, xxx F |
| 2 | ETM-5C-Q-R | ETM-5C-G-R | EDGE™ Tap Module, 50/50 split ratio (live/tap), one rear-mounted pinned red MTP® adapter labeled TAP, two pinned MTP adapters labeled LIVE, enables six monitored ports |
| 3 | G757548QPNDUxxxF | G909048GPNDUxxxF | 48-fiber MTP (non-pinned) to MTP (non-pinned) Trunk; xxx feet (Note: Trunks available in fiber counts up to 576F) |
| 4 | EDGE-CP48-E3 | EDGE-CP48-90 | EDGE™ 48-fiber MTP Connector Panel |

| | | | |
|---|--------------------|--------------------|---|
| 5 | J759312QE8-NAxxx F | J899012GE8-NAxxx F | 12-fiber MTP® Jumper, MTP® PRO (pinned) to MTP® PRO (non-pinned), TIA-568 Type-A polarity, no pulling grip, xxx F |
| 6 | HE50308QPH-KBxxx F | HE70208GPH-KBxxx F | EDGE8® Tap Harness, xxx F, Pinned MTP PRO to LC Simplex |

Bill of Materials for Figure 16 - EDGE8 (Base 8)

| Item | OM4 Part Number | OS2 Part Number | Description |
|------|--------------------|--------------------|---|
| 1 | JE6E608QE8-NBxxx F | JE8E808GE8-NBxxx F | 8-fiber MTP® PRO Jumper, MTP® PRO 8F (non-pinned) to MTP® PRO 8F (non-pinned), TIA-568 Type-B Polarity, no pulling grip, xxx F |
| 2 | ETM8-50C-Q-R | ETM8-50C-G-R | EDGE8® Tap Module, 50/50 split ratio (live/tap), pinned Live MTP adapter on the front of the module and non-pinned Live and Tap (red) MTP adapters on the rear |
| 3 | GE5E548QPNDDUxxx F | GE7E748GPNDDUxxx F | EDGE8® MTP® Trunk, 48 Fibers, MTP 8F (Pinned) to MTP 8F(Pinned), TIA-568 Standard Universal Type-B Polarity, Pulling grip on first end only, xxx F, Non-Armored |
| 4 | EDGE8-CP32-V3 | EDGE8-CP32-V1 | EDGE8® 32-fiber MTP Connector Panel |
| 5 | JE6E608QE8-NAxxx F | JE8E808GE8-NAxxx F | 8-fiber MTP® PRO Jumper, MTP® PRO 8F (non-pinned) to MTP® PRO 8F (non-pinned), TIA-568 Type-A Polarity, no pulling grip, xxx F |
| 6 | HE60308QPH-KBxxx F | HE80208GPH-KBxxx F | EDGE8® Tap Harness, xxx F, Non-Pinned MTP® PRO to LC Simplex |

Conclusion

The best tap application deployment to monitor a network will depend on many factors such as design, equipment port and location; migration path, distance, cost, pathway availability, etc. For additional questions, contact Corning Optical Communications' Technical Support Line at 800-743-2671 or dutyeng@corning.com.

CORNING

References

Appendix A:

Polarity of Figure 4

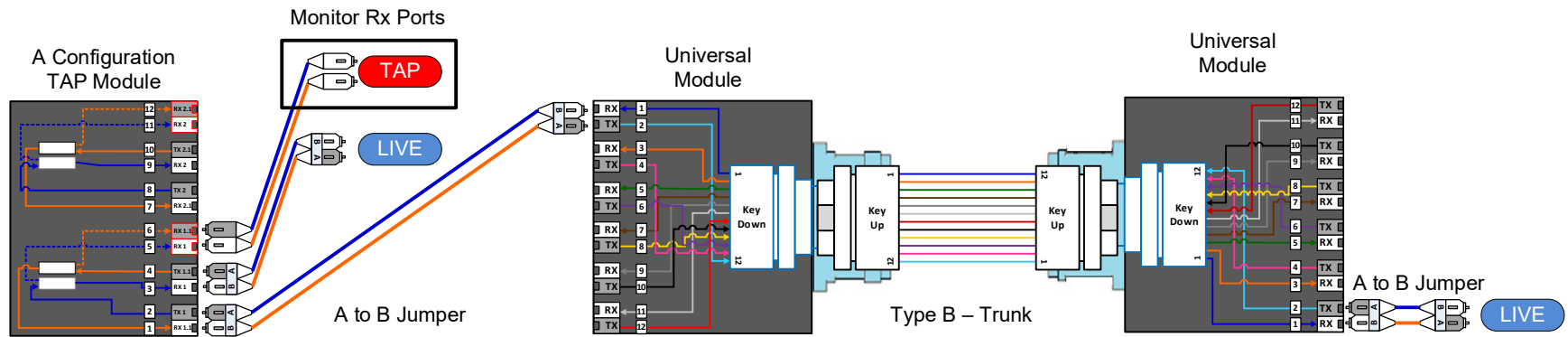

Polarity of Figure 5

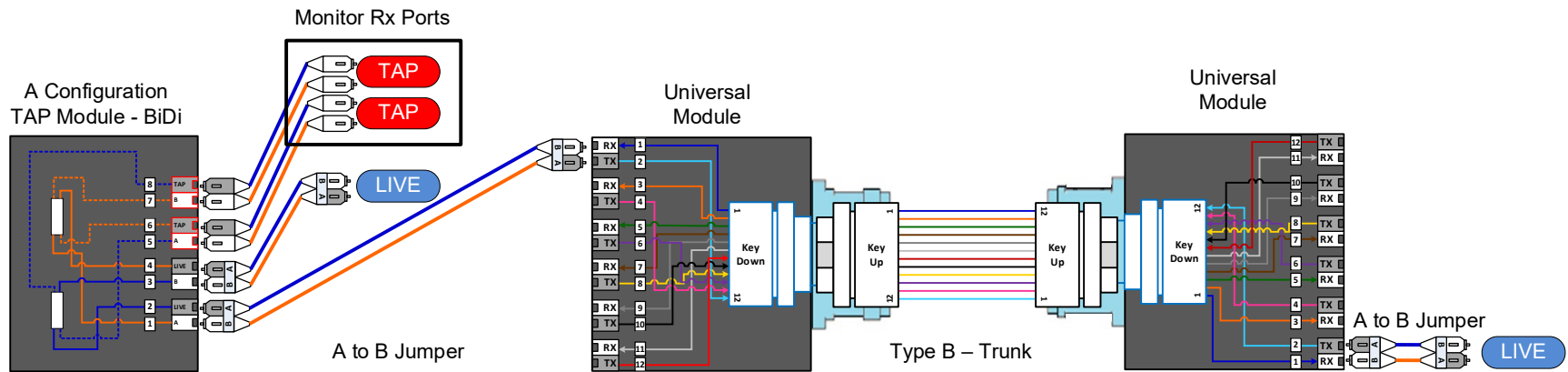

Polarity of Figure 6

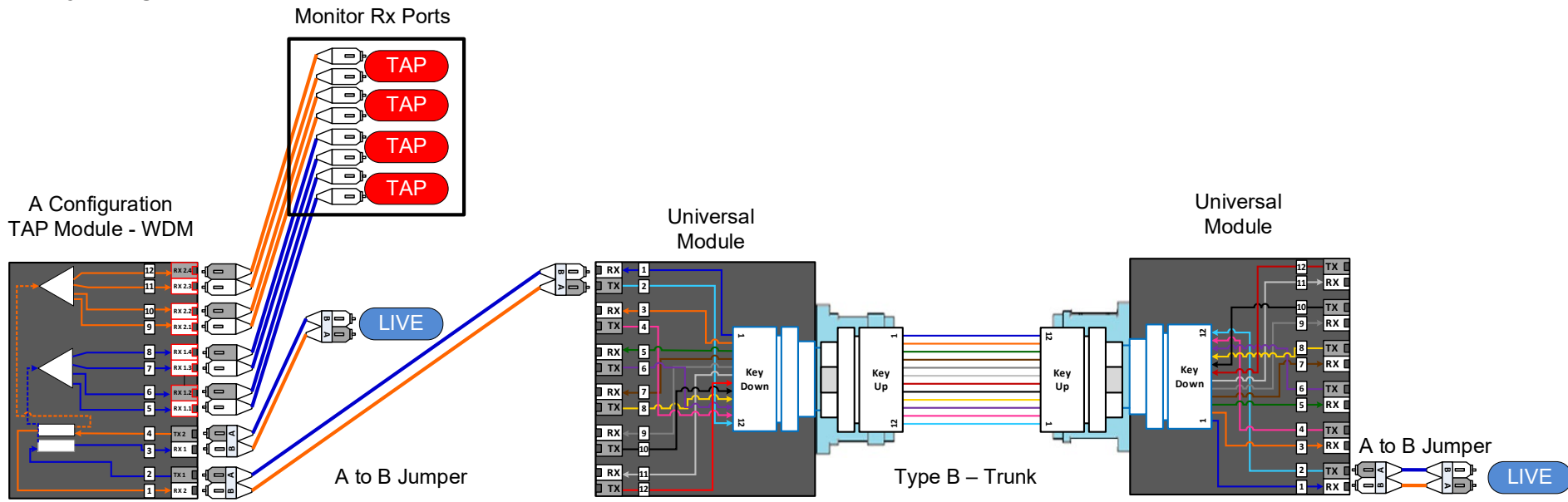

Polarity of Figure 7

B Configuration
TAP Module

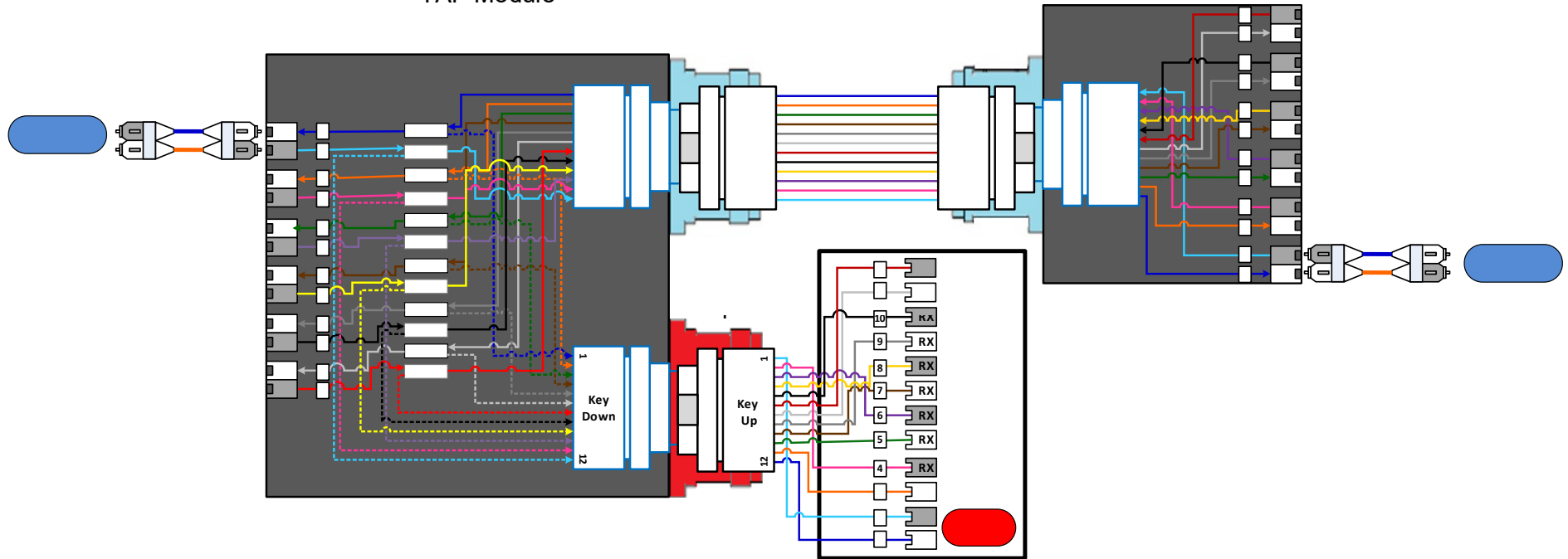

Polarity of Figure 8

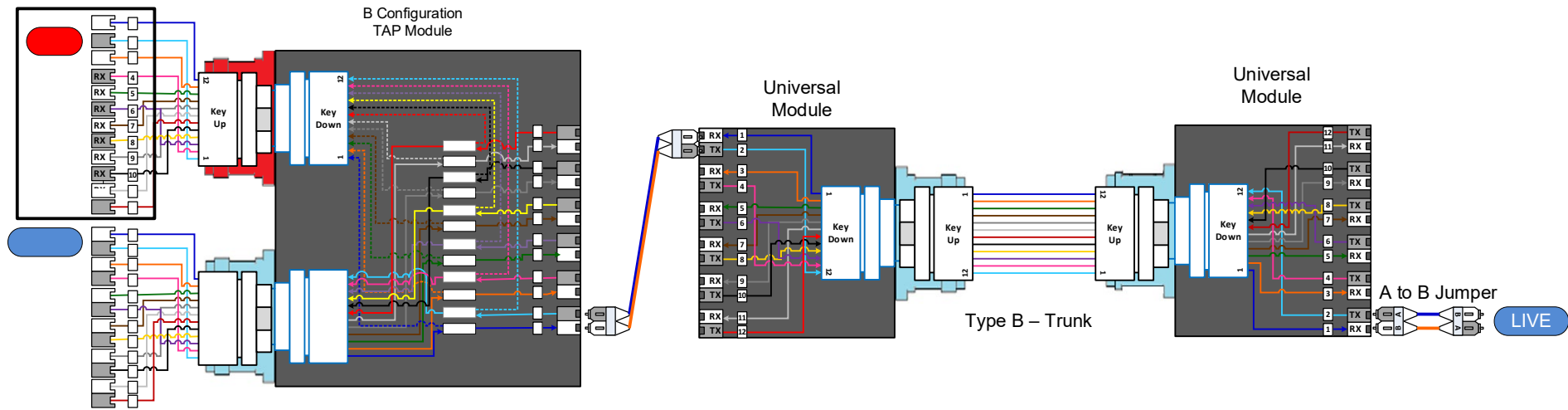

Polarity of Figure 9

B Configuration
TAP Module

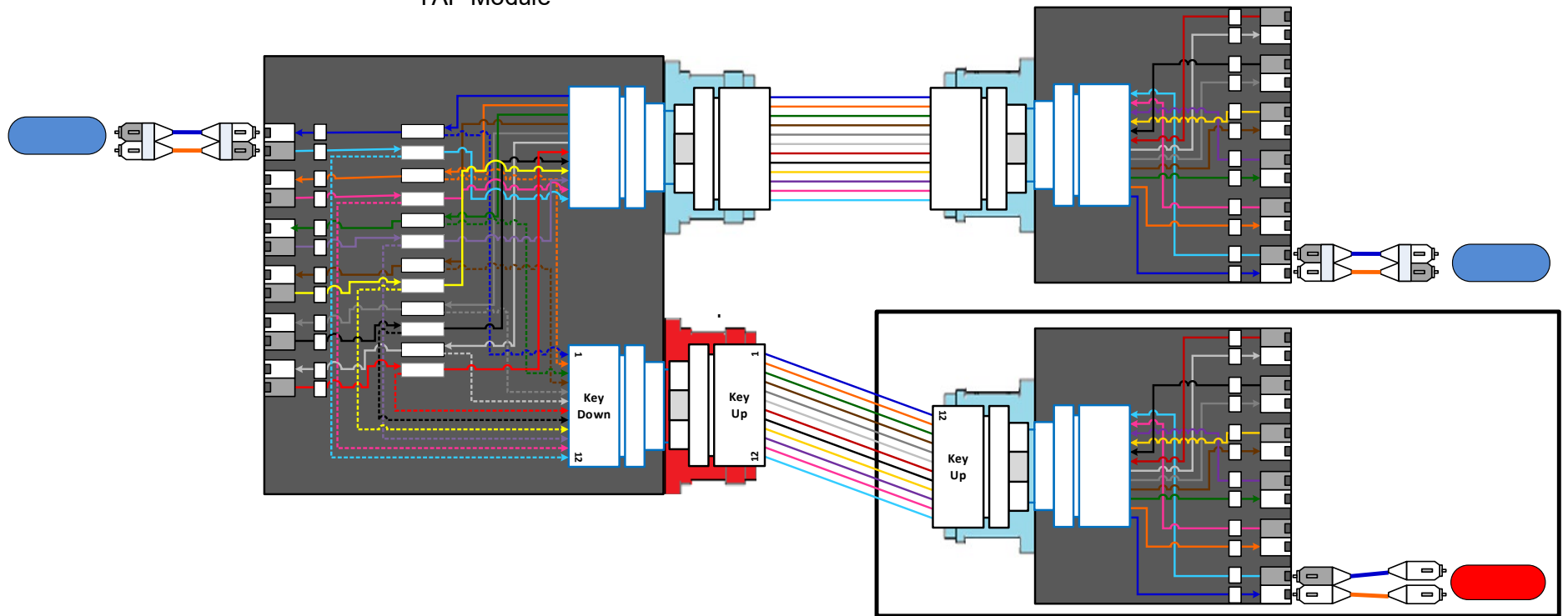

Polarity of Figure 10

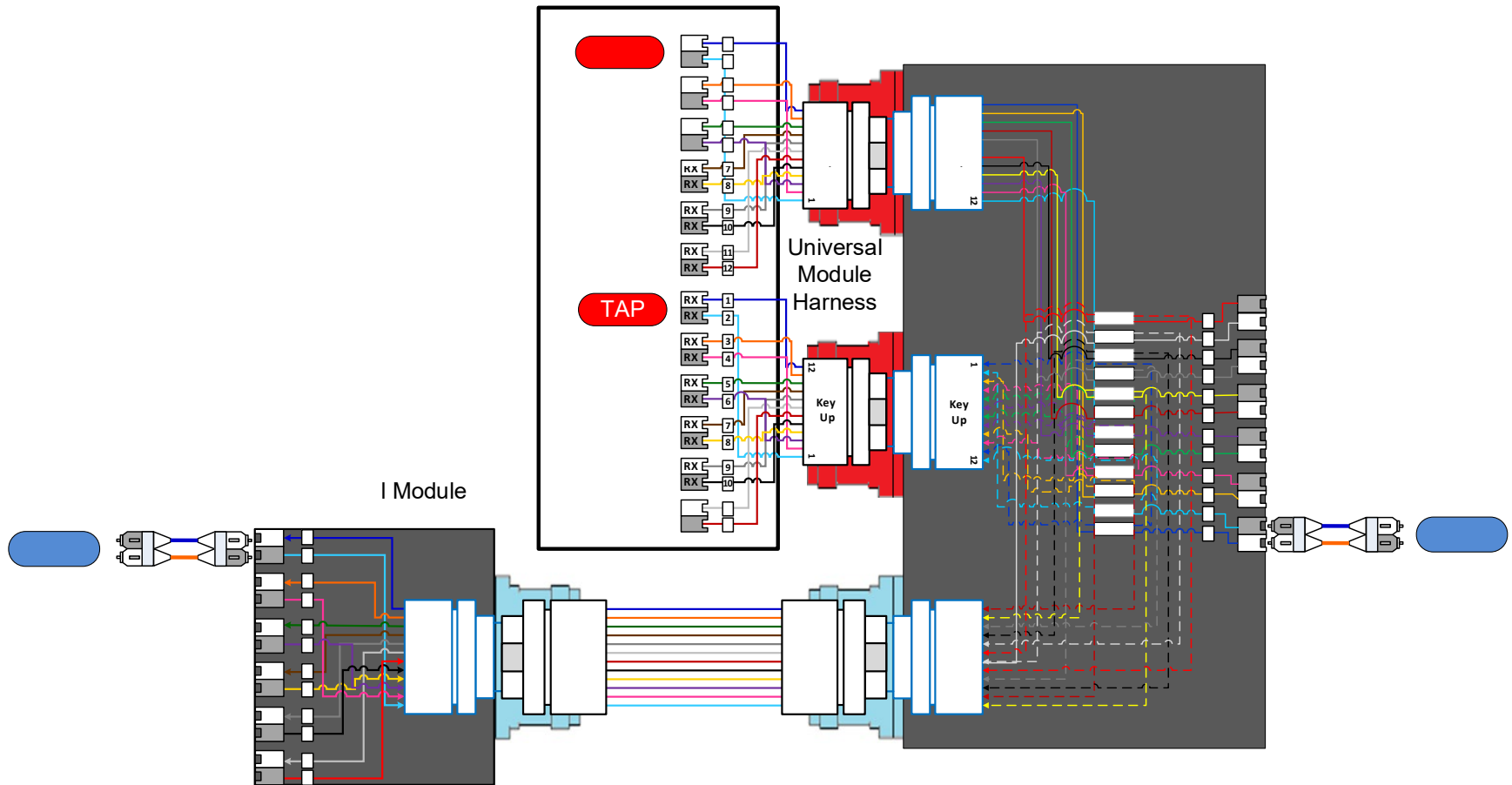

Polarity of Figure 11

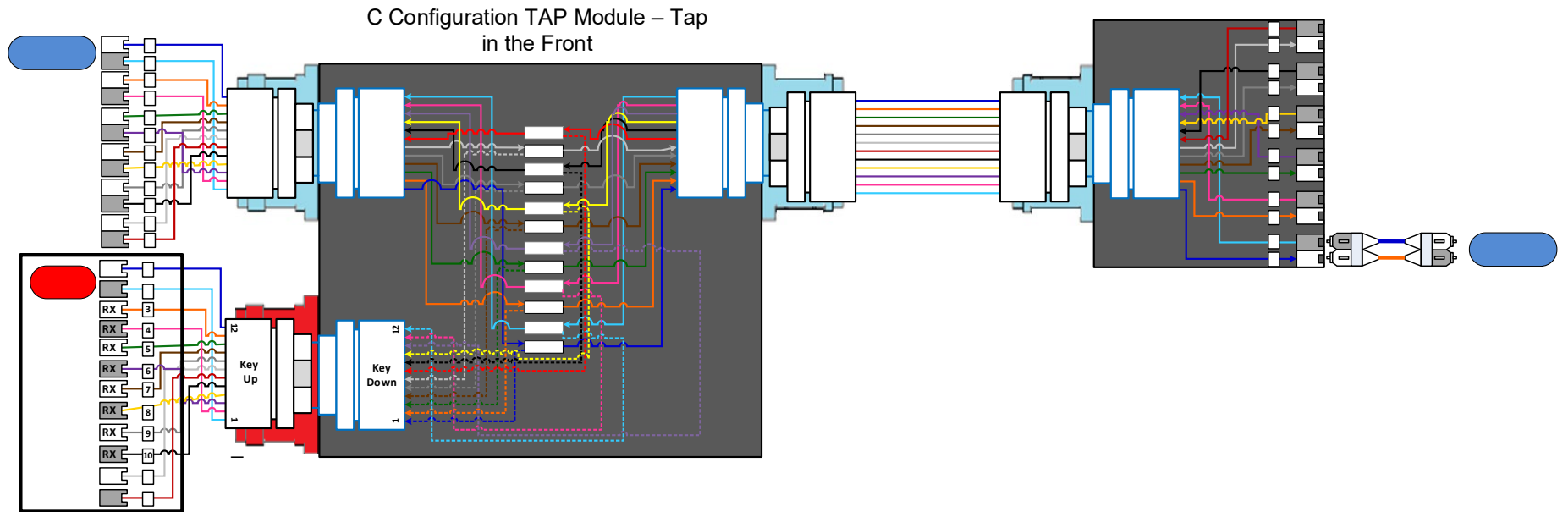

Polarity of Figure 12

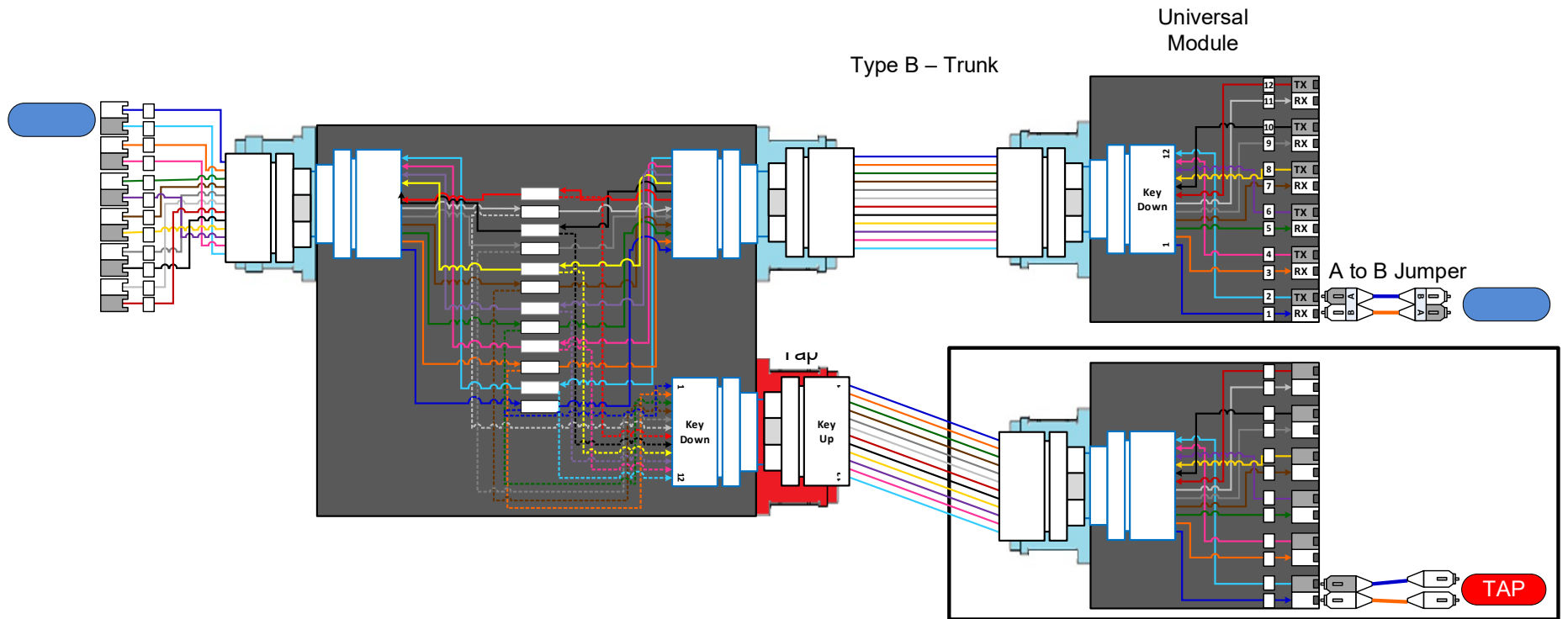

Polarity of Figure 13

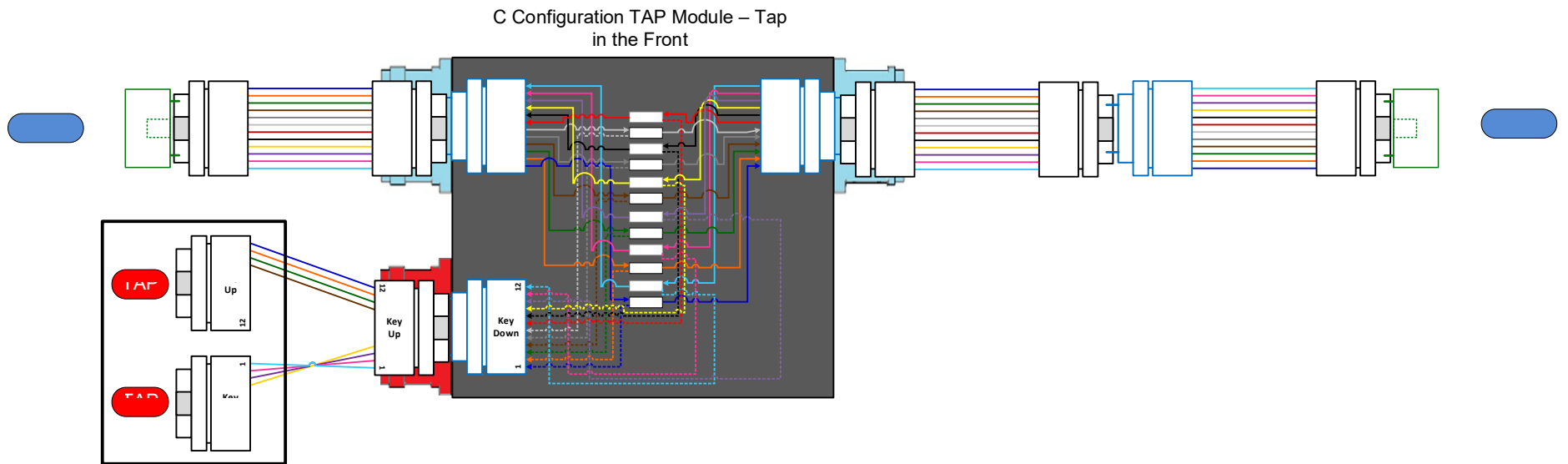

Polarity of Figure 14

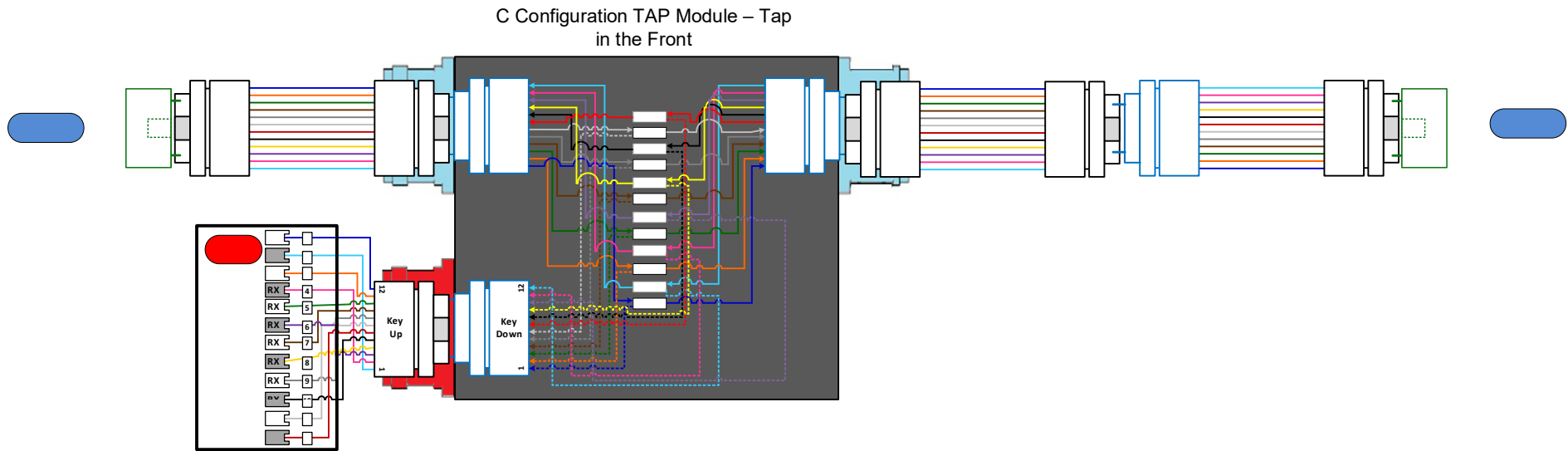

Polarity of Figure 15

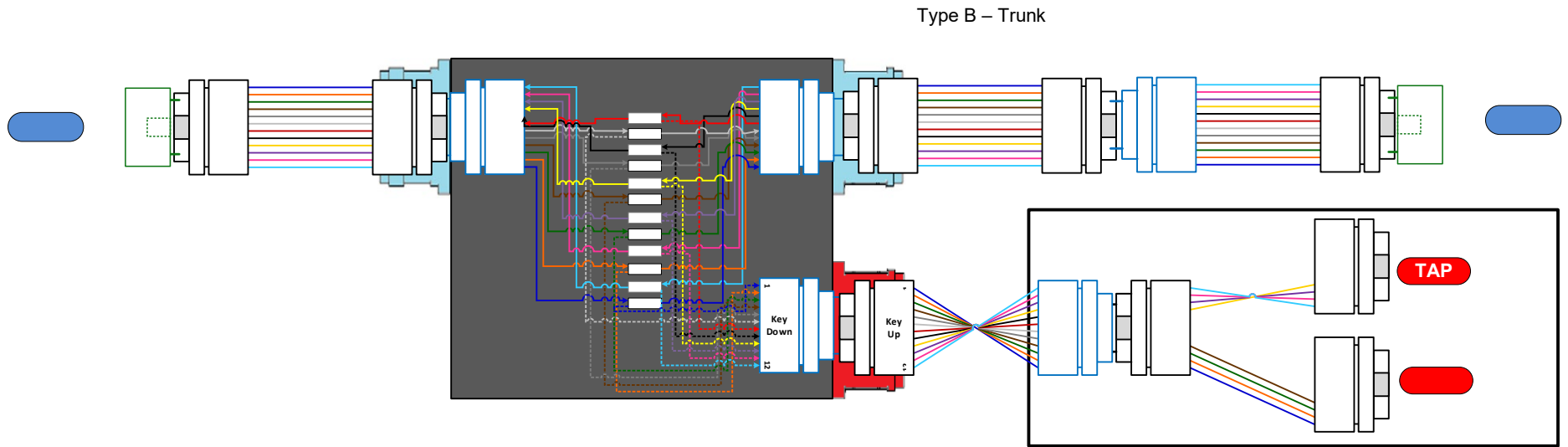

Polarity of Figure 16

