

Four-channel Parallel to Duplex Optical Connectivity Solutions Utilizing Base-12 Structured Cabling

AEN 152, Revision: 2

This Application Engineering Note will discuss the different Corning Optical Communications components that are available to provide fiber optic connectivity between parallel Quad Small Form-factor Pluggable (QFSP) transceivers and Small Form-factor Pluggable (SFP) transceivers (for example fiber optic connectivity between 40GbE transceivers and 10GbE transceivers). This document will be specific by providing connectivity solutions that use OM3/OM4 Laser-Optimized 50µm multimode and OS2 single-mode fiber (This document will only provide OM4 and OS2 part numbers). This document will cover parallel (8-fiber) to duplex (2-fiber) optical links. For Base-12 parallel (8-fiber) solutions, please refer to AEN151 “Four-Channel Parallel Optic Connectivity Solutions Utilizing Base-12 Structured Cabling”. For Base-8 solutions, please refer to AEN156 “Connectivity Solutions Utilizing Base-8 Structured Cabling”.

A QFSP transceiver can be either an 8-fiber parallel link or a 2-fiber duplex link. In this document when QFSP is used we will be discussing an 8-fiber parallel link.

These QFSP to SFP structured solutions may be deployed; but not limited to any of the following reasons:

- For breakout applications where the access layer switches have QSFP ports yet, only SFP server connections are required.
- For new access layer switch deployments where the top-of-rack access switch has QSFP uplink ports back to an existing core/aggregation switch with SFP ports.
- For space limited high-density application for port aggregation. For example, a typical SFP+ 10GbE line card will typically support 48 ports, but there are commercially available QSFP+ 40GbE line cards that can support 36 ports. That is the equivalent of one hundred and forty four (144) 10GbE ports in the same space, thus offering three times the density of SFP+ ports.

Duplex and Parallel Optical Links

A duplex optical link, also known as duplex communications, is accomplished by using two fibers as shown in Figure 1. The optical signal will be transmitted on the B connector and received on the A connector. For these types of links operating in a duplex optical system, the most commonly used connector is the duplexed LC.

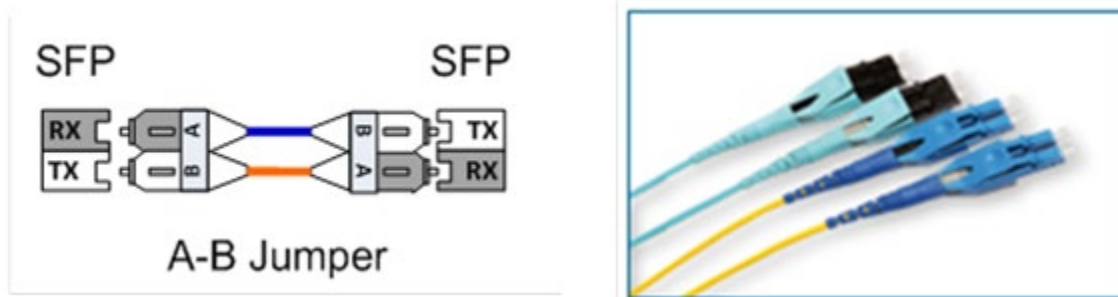

Figure 1: Duplex Fiber Optic Transmission

A parallel optical link is accomplished by combining two or more channels. Parallel optical links can be achieved by using eight fibers (4 fibers for Tx and 4 fibers for Rx), twenty fibers (10 fibers for Tx and 10 fibers for Rx), or twenty-four fibers (12 fibers for Tx and 12 fibers for Rx). The standard cabling to accomplish an 8-fiber parallel optical link is a 12-fiber trunk with a MTP® connector interface (12-fiber connector), as shown in Figure 2.

For parallel connectivity (8-fiber), Tx1 has to follow a path that requires the data to exit on Rx1. As Figure 1 illustrates if Tx1 enters on fiber position 1 it needs to exit on fiber position 12. This is the same if the transmit enters on fiber position 12 it needs to exit on fiber position 1. This is accomplished by using a Type B polarity component (according to TIA-568). As components are added to the optical system an odd number of Type B components are required to maintain the correct polarity scheme so the light enters and exits (transmit versus receive) the correct fiber positions.

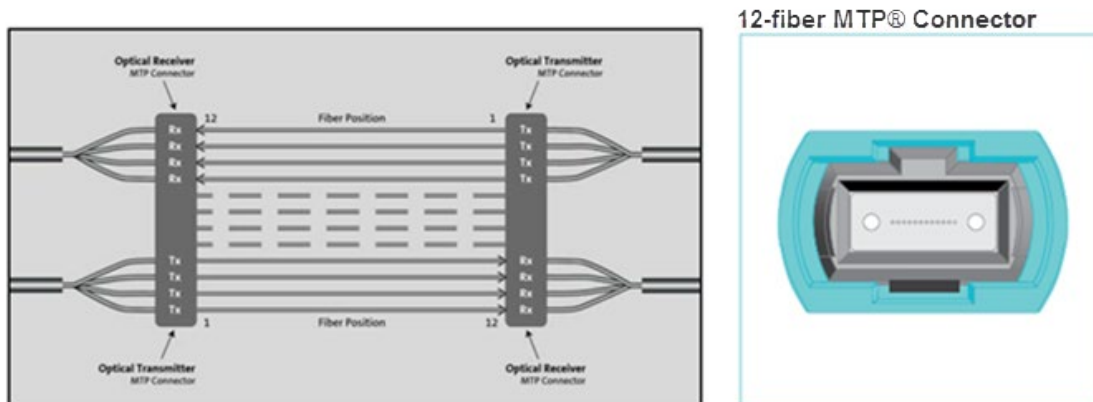

Figure 2: Parallel Fiber (8-fiber) Optic Transmission

After the brief explanations of parallel transmission over eight fibers and duplex over two fibers you may think to yourself that it could be difficult to combine these two connectivity options. This AE Note will aid the designer by providing the Corning Optical Communications products that are needed to connect to the QSFP port (eight fibers), separate the fibers into the correct sequence (proper polarity) and connect to the SFP (two fiber) port on the other end of the optical network.

Before continuing to read this document it is suggested to review or read Application Engineering Note 151, “Four-Channel Parallel Optic Connectivity Solutions Utilizing Base-12 Structured Cabling”. AEN 151 discusses the fundamental approaches for 8-fiber Parallel Optics and the reasons they are used in a structured cabling fiber optic solution. This would be useful background information as we move forward through this document.

At the end of this document you will find all the polarity drawings for Corning Optical Communications products that are being discussed throughout this AE Note in Appendix A.

Direct Connectivity Solutions

When directly connecting a QSFP port to the four corresponding SFP ports, an eight fiber LC harness is required. The harness will have four LC Duplex connectors and the fibers will be paired in a specific way, assuring the proper polarity is maintained. This type of direct connectivity is only suggested for short distances within a given row or in the same rack/cabinet. Figure 3 shows the QSFP transceiver connected to four SFP transceivers.

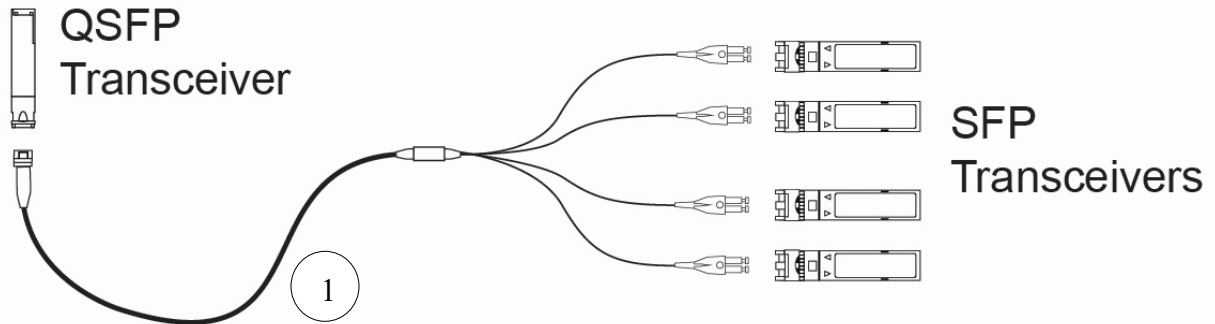

Figure 3: Harness Only – Direct Connect Structured Cabling

Bill of Materials for Figure 3			
Item	OM4 Part Number	OS2 Part Number	Description
1	HE67908QPH-KBxxxF	HE87808GPH-KBxxxF	EDGE8™ Type-B Harness, MTP® (non-pinned), 8 Fibers, xxx ft., 24-in LC Uniboot legs

Interconnect Solutions

The interconnect solution shown in Figure 4 shows one link with a breakout of the QSFP with the use of an EDGE™ Module to four SFP links. A Type-B non-pinned MTP® to non-pinned MTP assembly is used between the EDGE module and QSFP transceiver. The connection to the SFP transceivers is accomplished with Uniboot LC duplexed jumpers. This is a solution that is only recommended for short distances, where the patching takes place within a given row of racks/cabinets. This solution does present some disadvantages which are that ports 5 & 6 of the module are not being used thus reducing the patch panel density. It may also create some confusion when patching occurs since these two ports are dark.

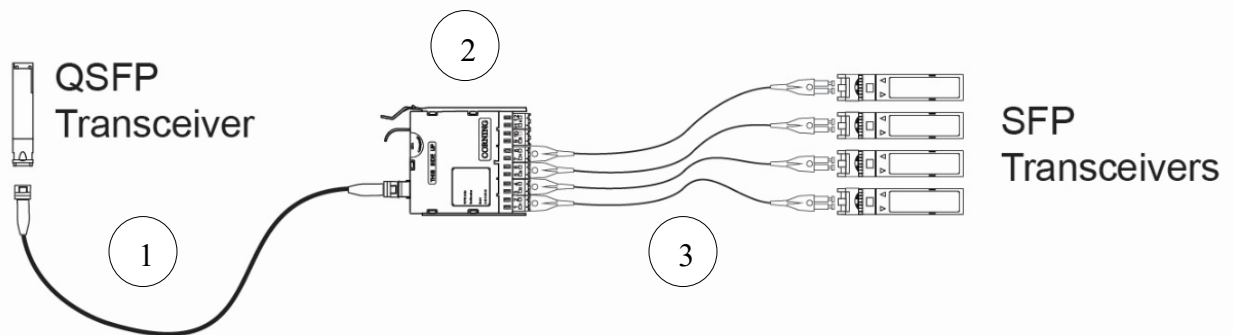

Figure 4: Jumpers and Module – Inter-connect Structured Cabling

Bill of Materials for Figure 4			
Item	OM4 Part Number	OS2 Part Number	Description
1	J757512QE8-NBxxxF	J909012GE8-NBxxxF	EDGE, MTP (non-pinned) to MTP (non-pinned), 12 F Jumper, TIA-568 Type-B polarity, xxx ft.
2	ECM-UM12-05-93Q	ECM-UM12-04-89G	EDGE Low Loss Module, LC Duplex to MTP (pinned), 12 Fibers
3	797902QD120xxxF	787802GD120xxxF	EDGE LC Uniboot to LC Uniboot Duplex Jumper, Riser, xxx ft.

Unlike the patching approach in Figure 4, the solution shown in Figure 5 has no dark fibers or ports. The Type-B jumper is replaced with an eight-fiber harness. The modules are replaced with the EDGE LC/LC adapter panel. Using this approach allows full patch panel density that was lost in the previous example. Only two EDGE LC/LC adapter panels will be required for every three 8-fiber harnesses. All ports on the EDGE LC/LC adapter panels will be used and the connections to the 10GbE ports will be completed with an Uniboot LC duplexed jumper. This solution should also be deployed when there is a short distance between active components (within the same row). Note the LC panel

does not support the LC Uniboot connector, only LC Duplex connectors with the triggers removed to avoid clearance issues with the panel cover.

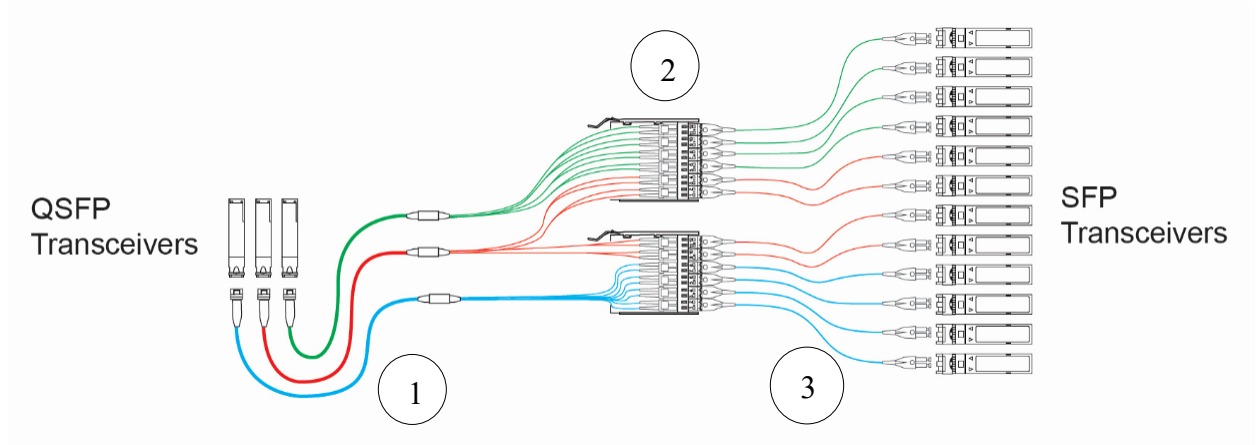

Figure 5: Jumpers, Harnesses and EDGE™ LC/LC Adapter Panel Inter-connect Structured Cabling

Bill of Materials for Figure 5			
Item	OM4 Part Number	OS2 Part Number	Description
1	HE60508QPH-KBxxxF	HE80408GPH-KBxxxF	Plug & Play® Type-B Harness, MTP® (non-pinned), 8 Fibers, xxx ft., 24-in LC Duplex legs
2	EMOD-CP12-AD	EMOD-CP12-AE	EDGE Solutions, Adapter Panel, LC Duplex, 12 F
3	797902QD120xxxF	787802GD120xxxF	EDGE LC Uniboot to LC Uniboot Duplex Jumper, Riser, xxx ft.

The structured cabling solution in Figure 6 allows for patching on both ends of the optical network. The use of MTP trunks provides a robust solution that allows the cable to be placed in cable trays without the fear of the trunk cable being crushed. Structured cabling allows for easier moves, adds, and changes (MACs). The patching on the QSFP end is accomplished by using Type-A non-pinned MTP to pinned MTP jumpers, which connects to the trunk cable. The patching on the 10GbE end is accomplished using EDGE modules and Uniboot LC duplexed jumpers. This solution does present some disadvantages which are that ports 5 & 6 of the module are not being used thus reducing the patch panel density. It may also create some confusion when patching occurs since these two ports are dark. Not all of the fibers in the MTP to MTP jumpers and trunk will be utilized.

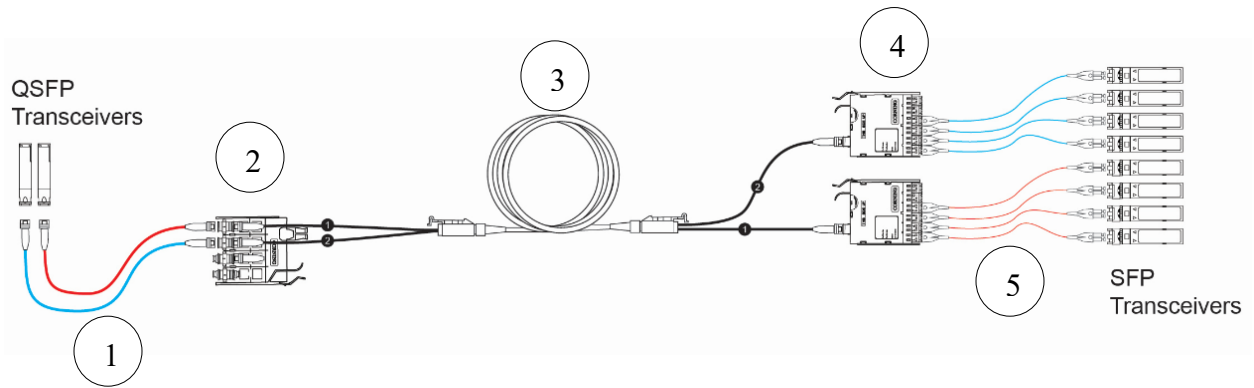

Figure 6: Jumpers, Trunks, Panels, and Modules - Inter-connect Structured Cabling

Bill of Materials for Figure 6			
Item	OM4 Part Number	OS2 Part Number	Description
1	J759312QE8-NAxxxF	J899012GE8-NAxxxF	EDGE™, MTP® (pinned) to MTP (non-pinned), 12 F Jumper, TIA-568 Type-A polarity, xxx ft.
2	EDGE-CP48-E3	EDGE-CP48-90	EDGE 48 Fibers MTP Adapter Panel, (4 ports)
3	G757524QPNDUxxxF	G909024GPNDUxxxF	EDGE Trunk Cable, MTP Connector (non-pinned) to MTP Connector (non-pinned), 24 Fibers, with 33/33 inch legs, pulling grip one side, xxx ft.
4	ECM-UM12-05-93Q	ECM-UM12-04-89G	EDGE Low Loss Module, LC Duplex to MTP (non-pinned), 12 Fibers
5	797902QD120xxxF	787802GD120xxxF	EDGE LC Uniboot to LC Uniboot Duplex Jumper, Riser, xxx ft.

Note: EDGE trunk cables are available in fiber counts from 12 to 576 fibers.

The connectivity solution in Figure 7 is very similar to the previous example in Figure 6. The most obvious difference is the use of a conversion module in place of the MTP adapter panel. There is an additional connectivity cost of the conversion module when compared to MTP adapter panels, but at longer lengths, the savings of full fiber utilization offsets the cost of that extra connectivity. In addition, 100% fiber utilization of the trunk results in maximum utilization of cable pathways, since all fibers are used to carry traffic. One disadvantage of this approach is that the four links created by the middle QSFP (red in the diagram) will be split up to ports 5 & 6 on both modules, which could create management complexity.

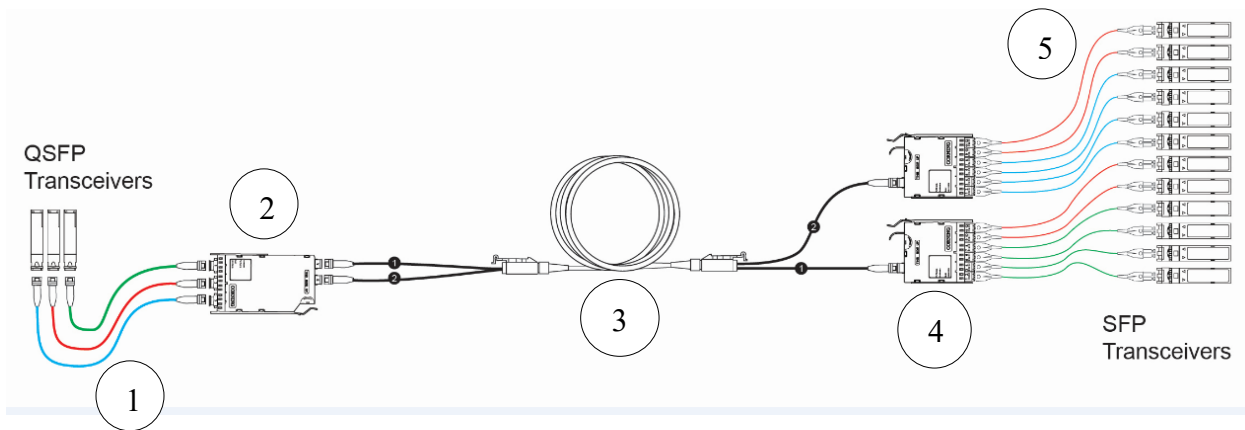

Figure 7: Jumpers, Conversion Modules, Modules, and Trunks Inter-connect Structured Cabling

Bill of Materials for Figure 7			
Item	OM4 Part Number	OS2 Part Number	Description
1	J757512QE8-NBxxxF	N/A	EDGE™, MTP® (non-pinned) to MTP (non-pinned), 12 F Jumper, TIA-568 Type-A polarity, xxx ft.
2	ECM-UM24-93-93Q	N/A	EDGE AO 2x3 Conversion Module, 24 F, Pinned MTP to Pinned MTP
3	G757524QPNDUxxxF	N/A	EDGE Trunk Cable, MTP Connector (non-pinned) to MTP Connector (non-pinned), 24 Fibers, with 33/33 inch legs, pulling grip one side, xxx ft.
4	ECM-UM12-05-93Q	N/A	EDGE Low Loss Module, LC Duplex to MTP (non-pinned), 12 Fibers
5	797902QD120xxxF	N/A	EDGE LC Uniboot to LC Uniboot Duplex Jumper, Riser, xxx ft.

Note: EDGE trunk cables are available in fiber counts from 12 to 576 fibers.

Figure 8 does not use conversion devices, resulting in some of the fibers in the trunk cable being dark. Another disadvantage of using this solution is that flexibility is lost on the SFP end because the transceiver ports need to be located in the same chassis. This is because the leg lengths for the LC Duplexed legs will be the same. Not all the fiber in the trunks or MTP to MTP jumpers will be utilized. However, this approach allows for an easy upgrade path moving from SFP to QSFP connectivity. To connect to SFPs one would use the 8-fiber harness as shown in the diagram. Or a MTP jumper could be used from the adapter panel for QSFP connectivity, thus allowing a mix and match upgrade path without having to change out the patch panels.

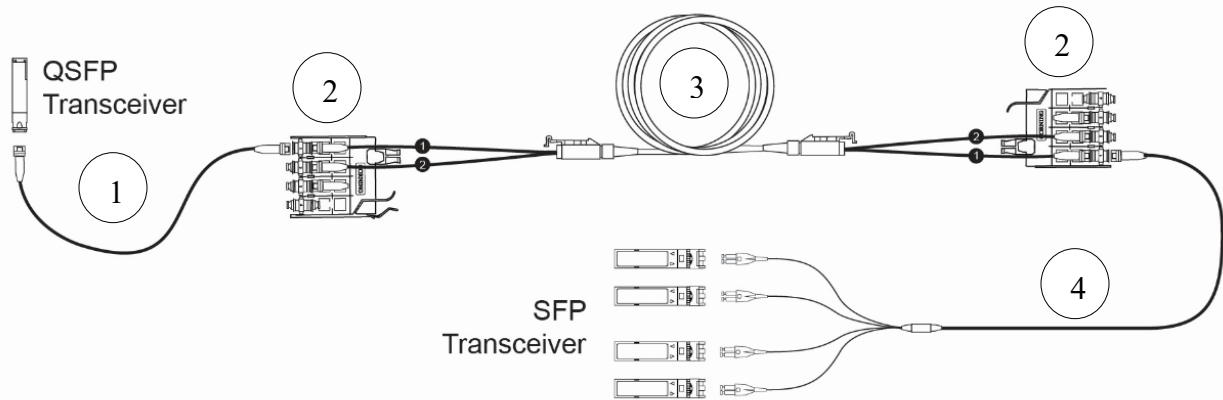

Figure 8: Jumpers, Panels, Harnesses and Trunks - Inter-connect Structured Cabling

Bill of Materials for Figure 8			
Item	OM4 Part Number	OS2 Part Number	Description
1	J759312QE8-NBxxxF	J899012GE8-NBxxxF	EDGE™, MTP® (pinned) to MTP (non-pinned), 12 F Jumper, TIA-568 Type-B polarity, xxx ft.
2	EDGE-CP48-E3	EDGE-CP48-90	EDGE 48 Fibers MTP Adapter Panel, (4 ports)
3	G757524QPNDUxxxF	G909024GPNDUxxxF	EDGE Trunk Cable, MTP Connector (non-pinned) to MTP Connector (non-pinned), 24 Fibers, with 33/33 inch legs, pulling grip one side, xxx ft.
4	HE57908QPH-KBxxxF	HE77808GPH-KBxxxF	EDGE8™ Type-B Harness, MTP (pinned), 8 Fibers, xxx ft., 24-in LC Uniboot legs

Note: EDGE trunk cables are available in fiber counts from 12 to 576 fibers.

The next structured solution in Figure 9 is almost identical to the example in Figure 8 except that conversion modules are used in place of the MTP adapter panels. This allows for 100% of the fiber in the trunk cables to be utilized. Similarly, the flexibility is lost on the 1SFP end because the transceiver ports need to be located in the same chassis. This is because the leg lengths for the LC Duplexed legs will be the same. However, this approach allows for an easy upgrade path moving from SFP to QSFP connectivity. To connect to SFPs one would use the 8-fiber harness as shown in the diagram. In addition an MTP jumper could be used from the conversion module for QSFP connectivity, thus allowing a mix and match upgrade path without having to change out the patch panels.

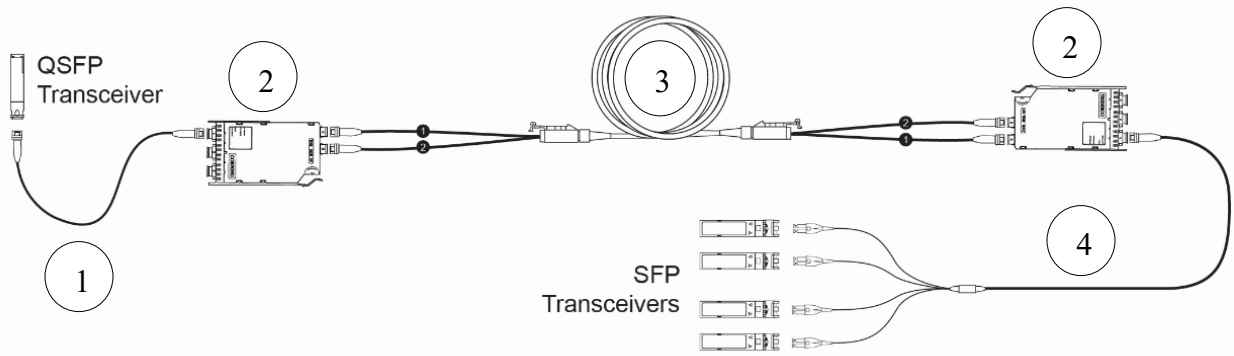

Figure 9: Jumpers, Harnesses, Conversion Modules and Trunks
Inter-connect Structured Cabling

Bill of Materials for Figure 9			
Item	OM4 Part Number	OS2 Part Number	Description
1	J757512QE8-NBxxxF	N/A	EDGE™, MTP® (non-pinned) to MTP (non-pinned), 12 F Jumper, TIA-568 Type-B polarity, xxx ft.
2	ECM-UM24-93-93Q	N/A	EDGE AO 2x3 Conversion Module, 24 F, Pinned MTP to Pinned MTP
3	G757524QPNDUxxxF	N/A	EDGE Trunk Cable, MTP Connector (non-pinned) to MTP Connector (non-pinned), 24 Fibers, with 33/33 inch legs, pulling grip one side, xxx ft.
4	HE67908QPH-KBxxxF	N/A	EDGE8™ Type-B Harness, MTP (non-pinned), 8 Fibers, xxx ft., 24-in LC Uniboot legs

Note: EDGE trunk cables are available in fiber counts from 12 to 576 fibers.

Cross-Connect Solution

The final solution in Figure 10 utilizes MTP trunk cables to provide a structured cabling solution with cross-connect connectivity and complete port replication. This solution will allow all MACs to be made at one location, usually the Main Distribution Area (MDA). The disadvantages of this solution would be that all the fibers in the MTP to MTP jumpers from the QSFP transceiver to the last adapter panel are not fully utilized and the flexibility is lost on the SFP end because the transceiver ports need to be located in the same chassis. This is because the leg lengths for the LC Duplexed legs will be the same. All of the configurations from the interconnect situation above could be deployed in a cross-connect deployment. In order to keep the document short, only a single situation is shown, but many other configurations are possible.

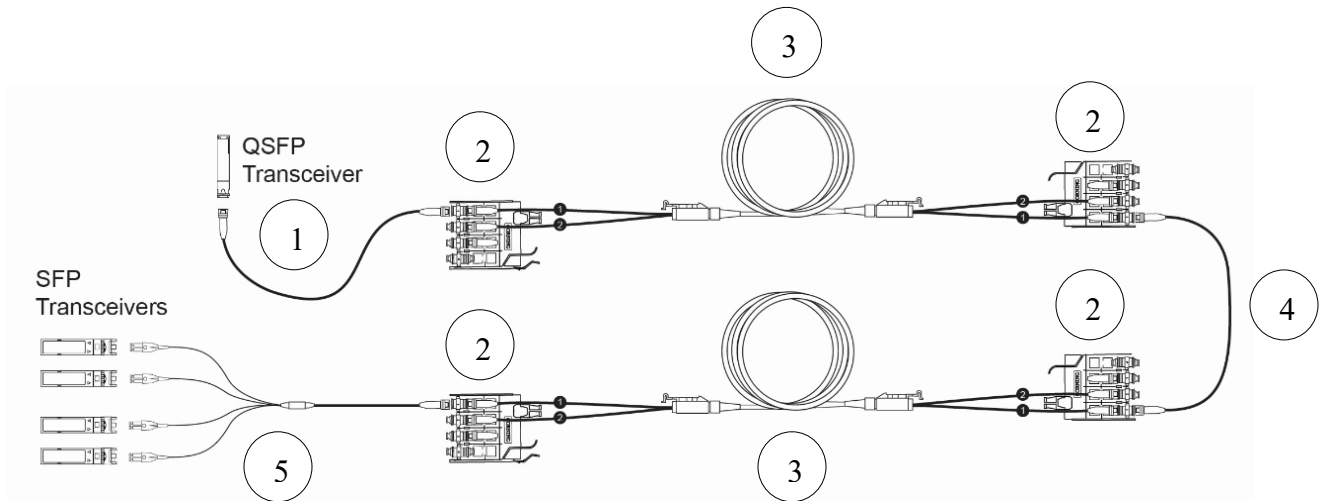

Figure 10: Jumpers, Panels, Trunks, and Harnesses - Cross-connect Structured Cabling

Bill of Materials for Figure 10			
Item	OM4 Part Number	OS2 Part Number	Description
1	J759312QE8-NBxxxF	J899012GE8-NBxxxF	EDGE™, MTP® (pinned) to MTP (non-pinned), 12 F Jumper, TIA-568 Type-B polarity, xxx ft.
2	EDGE-CP48-E3	EDGE-CP48-90	EDGE 48 Fibers MTP Adapter Panel, (4 ports)
3	G757524QPNDUxxxF	G909024GPNDUxxxF	EDGE Trunk Cable, MTP Connector (non-pinned) to MTP Connector (non-pinned), 24 Fibers, with 33/33 inch legs, pulling grip one side, xxx ft.
4	J939312QE8-NBxxxF	J898912GE8-NBxxxF	EDGE, MTP (pinned) to MTP (pinned), 12 F Jumper, TIA-568 Type-B polarity, xxx ft.
5	HE57908QPH-KBxxxF	HE77808GPH-KBxxxF	EDGE8™ Type-B Harness, MTP (pinned), 8 Fibers, xxx ft., 24-in LC Uniboot legs

Note: EDGE trunk cables are available in fiber counts from 12 to 576 fibers.

There are multiple ways to deploy a QSFP to SFP cabling infrastructure for your network. Utilizing OM3/OM4 Laser-Optimized 50µm multimode fiber or Single-mode OS2 for parallel optics applications. Some examples of protocols used for breakout applications are 40GBase-SR4, 40GBase-xSR4/cSR4/eSR4 transceivers to 10GBASE-SR transceivers.

One of the biggest challenges is to make sure the correct transmitting fibers are paired with their corresponding receiving fibers. Using Corning Optical Communications' pre-terminated products and the examples above allows for the transition from QSFP to SFP to take place smoothly while maintaining the correct polarity.

The best application for your network will depend on many factors such as design, equipment location, migration path, cost, pathway availability, etc. For additional questions, contact Corning Optical Communications' Technical Support Line at 800-743-2671 or dutyeng@corning.com.

Appendix A: Polarity Drawings for each scenario

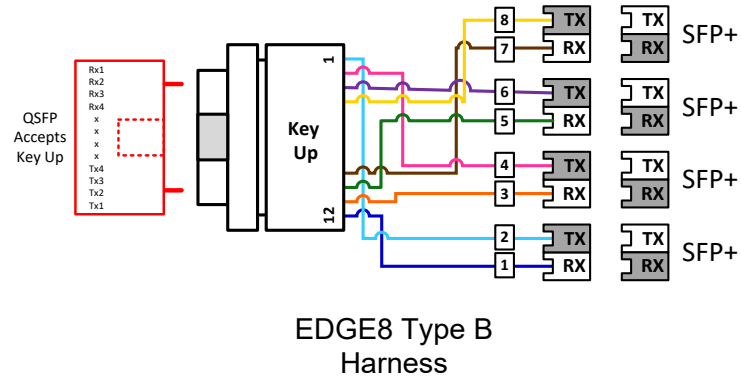

Figure 3-a: Harness Only – Direct Connect Structured Cabling

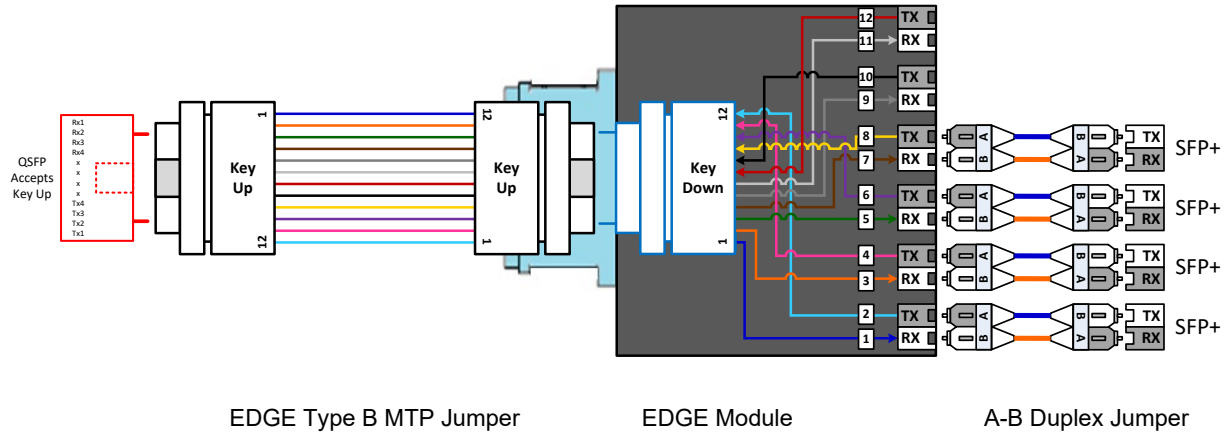

Figure 4-a: Jumpers and Module – Inter-connect Structured Cabling

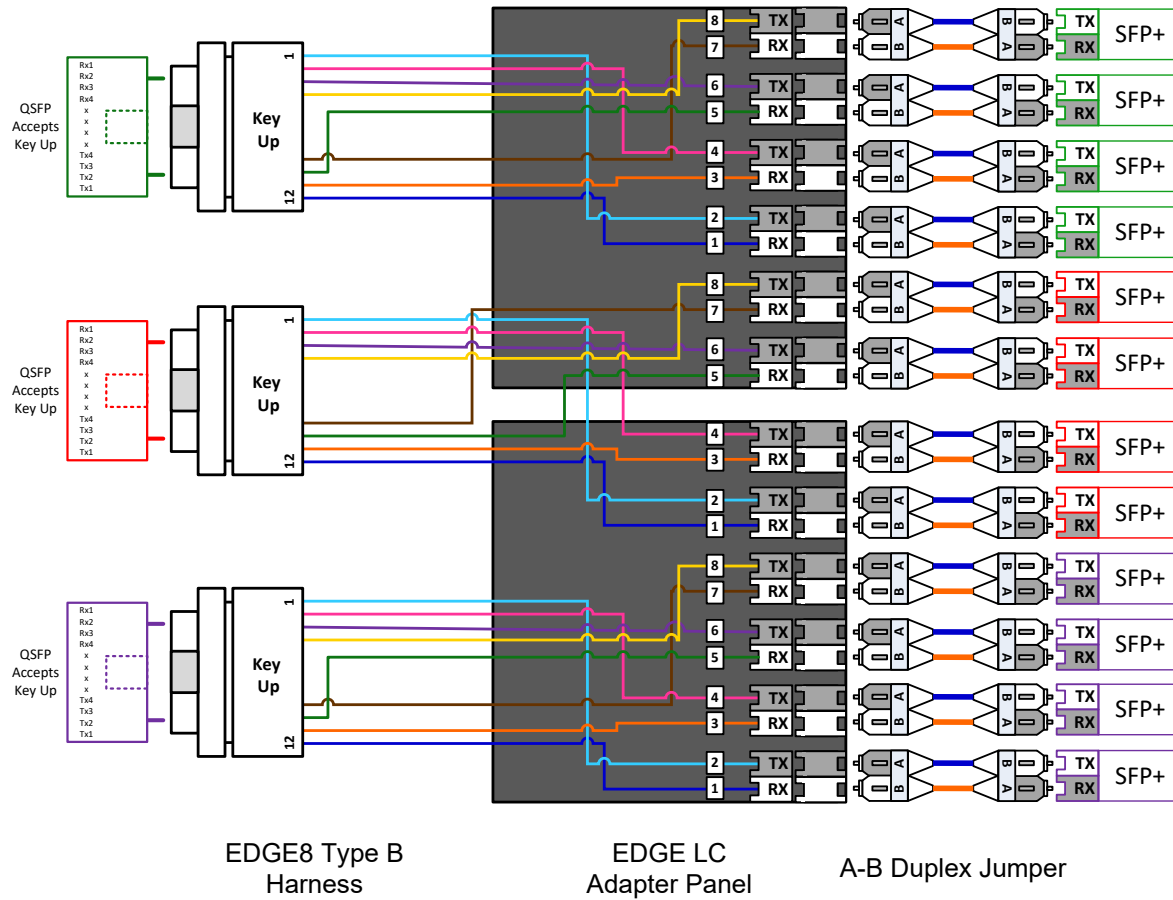

Figure 5-a: Jumpers, Harnesses and EDGE™ LC/LC adapter panel - Inter-connect Structured Cabling

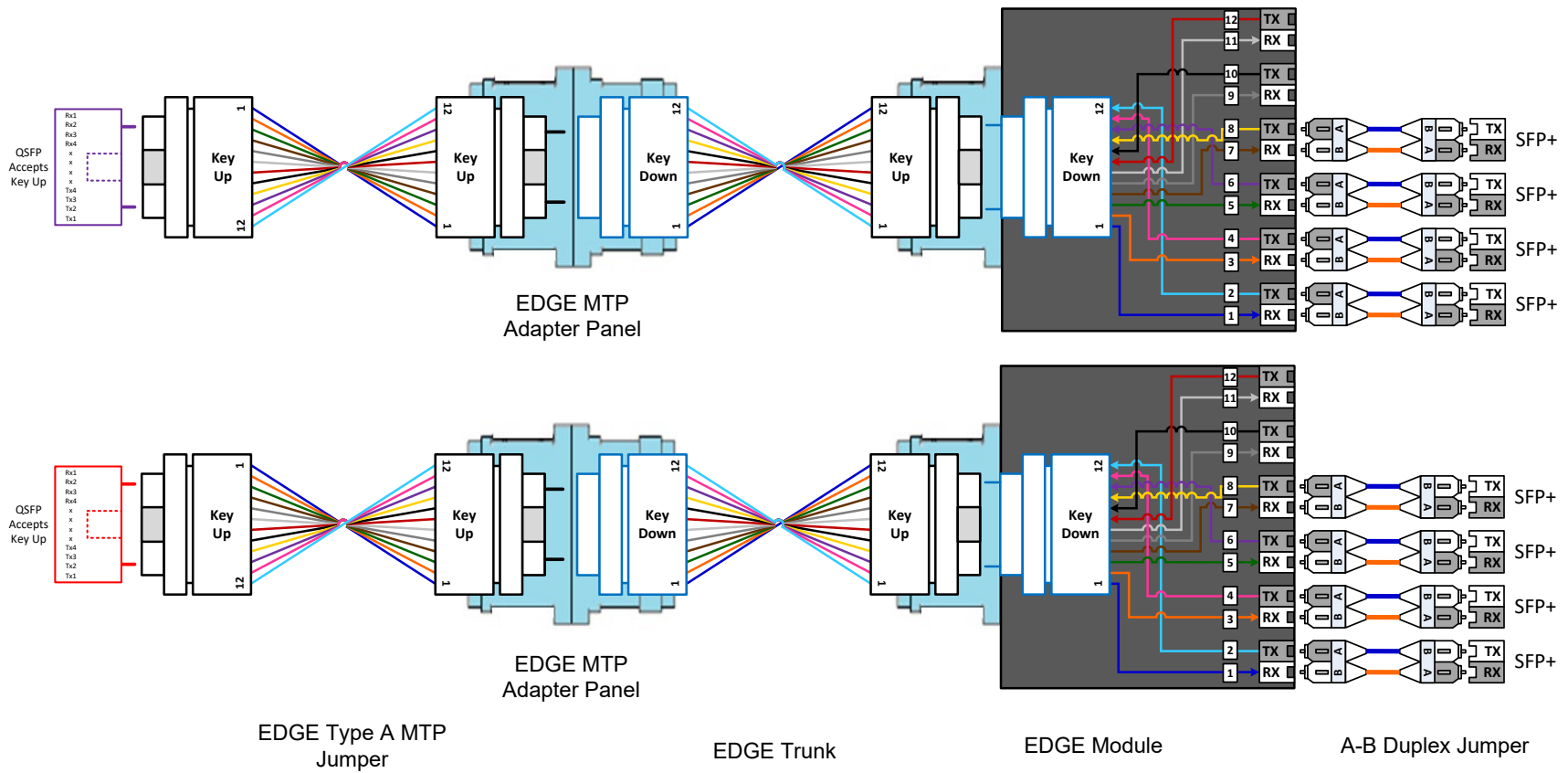

Figure 6-a: Jumpers, Trunks, Panels, and Modules - Inter-connect Structured Cabling

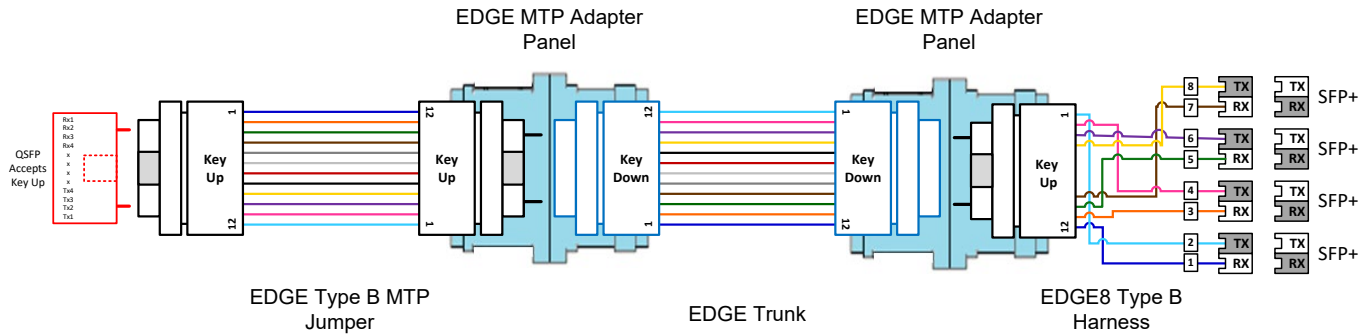

Figure 8-a: Jumpers, Panels, Harnesses and Trunks - Inter-connect Structured Cabling

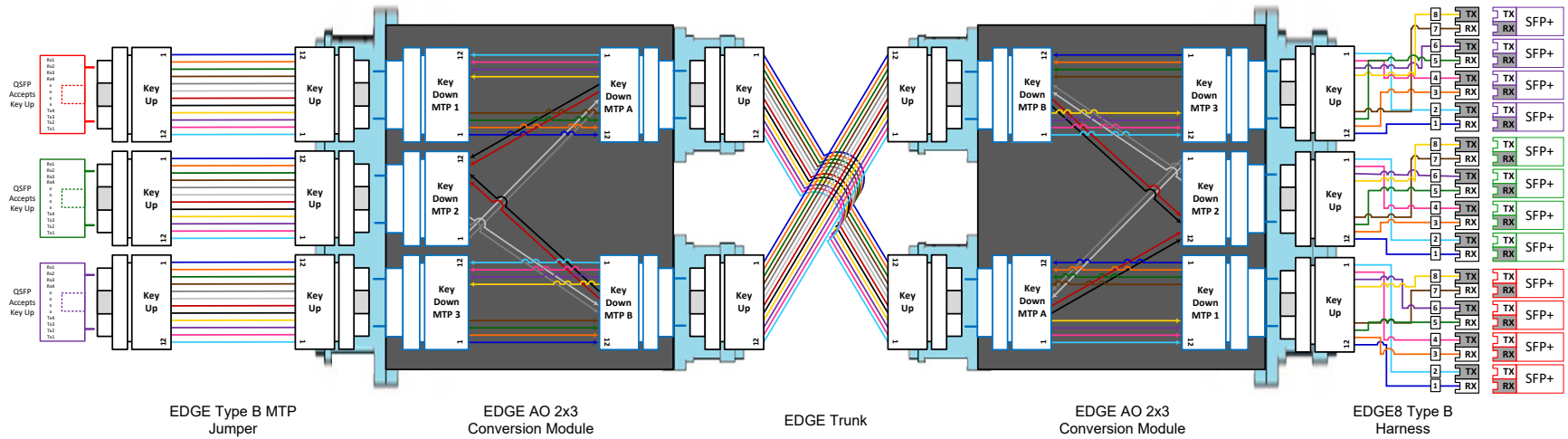

Figure 9-a: Jumpers, Harnesses, Conversion Modules and Trunks - Inter-connect Structured Cabling

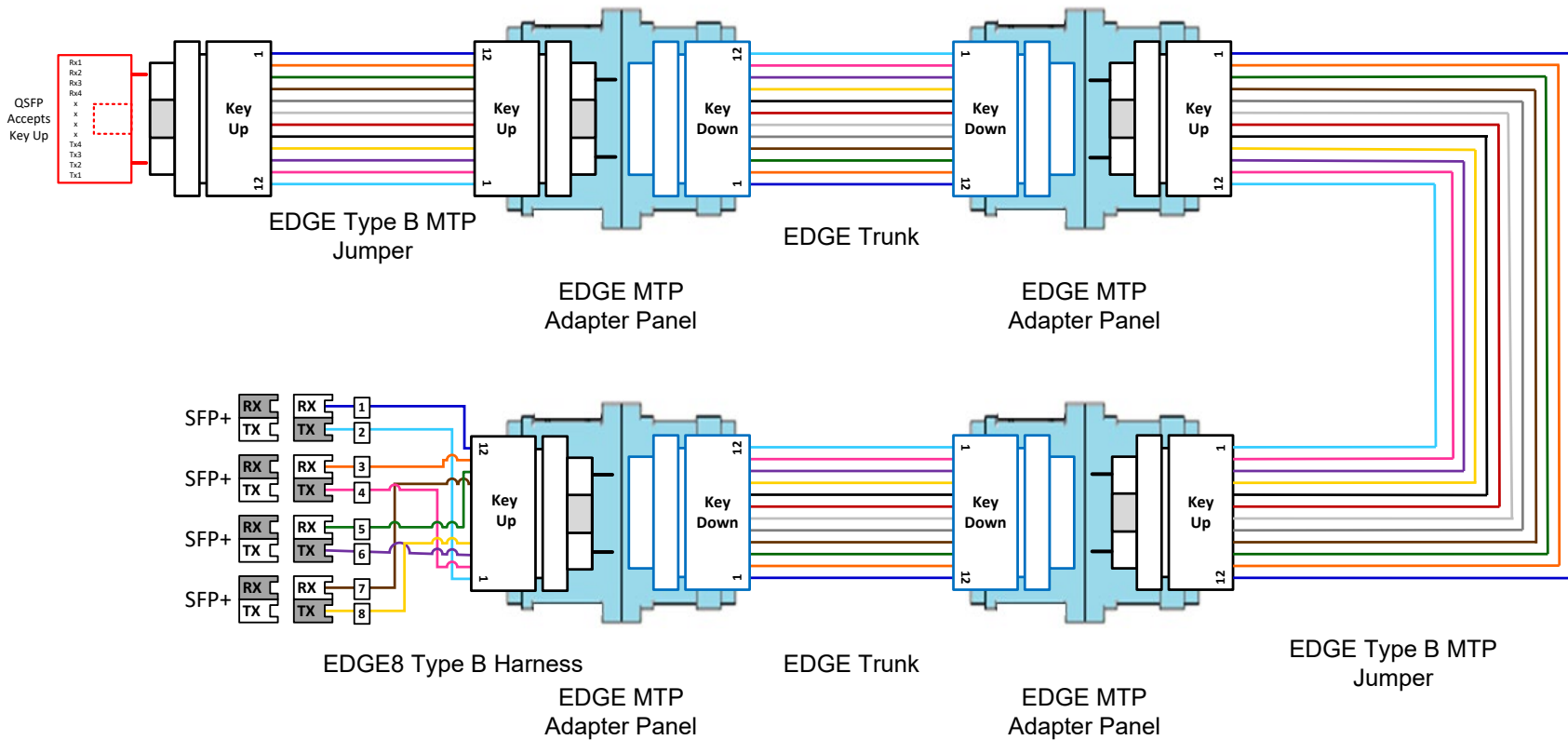

Figure 10-a: Jumpers, Panels, Trunks, and Harnesses - Cross-connect Structured Cabling