

The Importance of minEMBc Laser Bandwidth Measured Multimode Fiber for High Performance Premises Networks

White Paper

Optical
Fiber

CORNING

WP1150

Issued: October 2007
Supersedes: October 2006
ISO 9001 Registered

Dr. Russell Ellis

Senior Applications Engineer, Corning Optical Fiber

Introduction

Multimode optical fiber has long been the most attractive option for cost effective premises networks offering a smooth upgrade path from 10 Mb/s up to 10 Gb/s and beyond. As bandwidth demand continues to grow and network applications call for higher data rates, LEDs (light emitting diodes) are being replaced with VCSEL (vertical cavity surface emitting laser) based transceivers and high-performance multimode fibers are required to support multi-Gigabit protocols at a fraction of the cost of single-mode solutions. In 2006, Corning was the first fiber manufacturer to begin providing customers with the measured laser bandwidth values for its range of Laser Optimized™ InfiniCor® multimode fibers. This white paper explains why the most recently standardized laser bandwidth measurement method, minEMBc (calculated minimum effective modal bandwidth), is necessary for multi-Gigabit transmission over laser optimized multimode fibers and highlights the advantages of minEMBc over the foregoing DMD-normalized mask test method, developed during the early 10 Gigabit Ethernet standardization.

Contents

1. Migration to Laser Bandwidth Measured Multimode Fiber
 - Figure 1 Evolution of standardized multimode bandwidth measurement methods
 - Figure 2 Outline of standardized bandwidth test techniques for multimode fiber from OFL to minEMBc -reflecting evolution in multimode transceiver technology
2. DMD-Based Measurements for High Data Rate Applications
 - Figure 3 DMD Test Principle (normalized-mask pass/fail method illustrated)
3. minEMBc – Robust Bandwidth Certification for High Performance Multimode Fiber
 - Figure 4 Illustration of the minEMBc measurement used to certify InfiniCor Laser Optimized™ Fibers
4. Corning Laser Bandwidth Certification
 - Table 1 Corning InfiniCor fiber products and laser bandwidth measurement methods
5. Link Distance Performance from Laser Bandwidth Measurements
 - Figure 5 IEEE Ethernet link model and link budget values for 300 meters link featuring OM-3 multimode fiber 2000 MHz.km EMB OM-3 fiber
 - Figure 6 Extended 10Gb/s achievable link distance enabled with InfiniCor fibers
 - Figure 7 Extended 10 Gb/s Ethernet reach and connector/cable hardware flexibility
6. Summary: Corning InfiniCor Laser Optimized™ Multimode Fiber
7. References
8. Appendix A
 - Encircled Flux applied to the minEMBc Measurement Technique
 - Figure 1A Range of VCSEL sources characterised by EF for the IEEE 802.3ae standard
 - Figure 2A Calculated numerical weighting for a “hot-outside” emission patten VCSEL source (one of the 10 VCSELS sources)

Migration to Laser Bandwidth Measured Multimode Fiber

As bandwidth demand and data rates rise, the industry is transitioning to higher speeds from Mb/s to Gb/s requiring the use of multimode fiber with laser-based transceivers instead of slower speed LEDs. This transition is driven by widespread adoption of gigabit/multi-gigabit protocols (e.g. Gigabit Ethernet, Fibre Channel, etc.) and growing interest in 10 Gb/s ready solutions using low cost VCSEL technology. As a consequence networks migrating from LED-optimized- to laser-optimized multimode require fibers that are fully laser bandwidth certified and compatible with high speed VCSEL-based transceivers. The behavior of light coupled into a multimode fiber from a laser is very different to that from an LED (shown opposite). The smaller spot size of light emitted by a laser energizes fewer modes (paths of light) and with fewer modes excited, combined with the inherently higher modulation speed of lasers (ability to signal at higher frequencies), leads to laser-based transceivers enabling higher bandwidth capability with laser optimized multimode fibers.

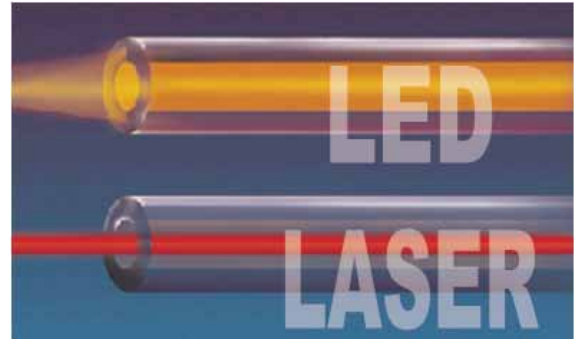

It has long been recognized (since the development of the Gigabit Ethernet standard IEEE 802.3z) that to accurately measure the higher bandwidth performance of multimode fiber suited to laser transmitters, requires more appropriate measurement techniques, reflecting the launch conditions of a laser transmitter¹. The transition from LED to laser-optimized fiber began in 1998 led by Corning's introduction of InfiniCor[®] multimode fibers. Figure 1 plots the evolution of premises standardized data rates over recent years and also illustrates how bandwidth measurement techniques have evolved alongside multimode fiber and increasing speeds. OFL (over-filled launch), used in the 1980's was superseded by the RML² (restricted modal launch) method, the first laser-optimized fiber bandwidth measurement technique, in 1998. During the development of the 10 Gigabit Ethernet Standard (IEC 802.3ae 2002), differential mode delay (DMD)³, a more complex laser bandwidth test method, was introduced reflecting the need for tighter bandwidth tolerances at higher speeds, way beyond the capability of OFL measurements. In 2004 DMD was superseded by minEMBC, developed and standardized⁴ as the most sophisticated laser-optimized fiber bandwidth measurement technique, providing more reliable certification over the full range of standards compliant transceivers and obtaining a more precise measure of individual fiber performance. High speed networks supporting multi-Gigabit/s data rates needing laser-based transceivers require minEMBC to guarantee field performance for current and future data rates needs. Other suppliers of multimode fiber products continue to use and specify legacy test methods, e.g. OFL, originally designed to predict the performance of LED optimized fibers rated for operation at data rates of typically of 10 – 100 Mb/s, that are not certified for use with lasers.

Evolution of standardized multimode bandwidth measurement methods

Figure 1

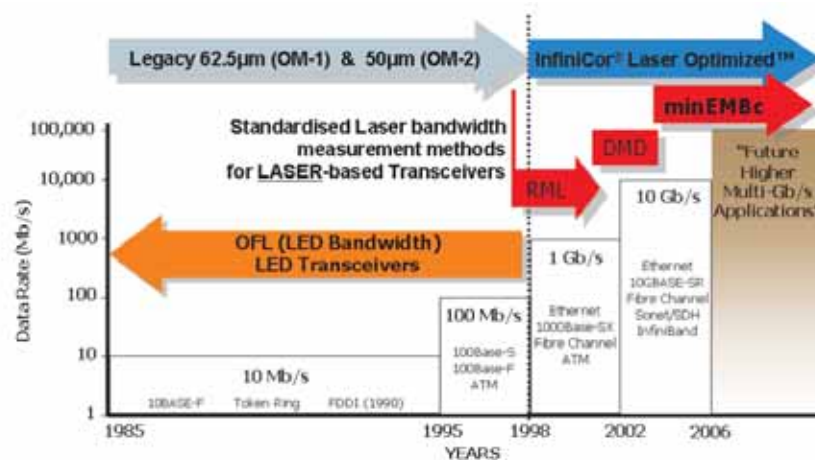
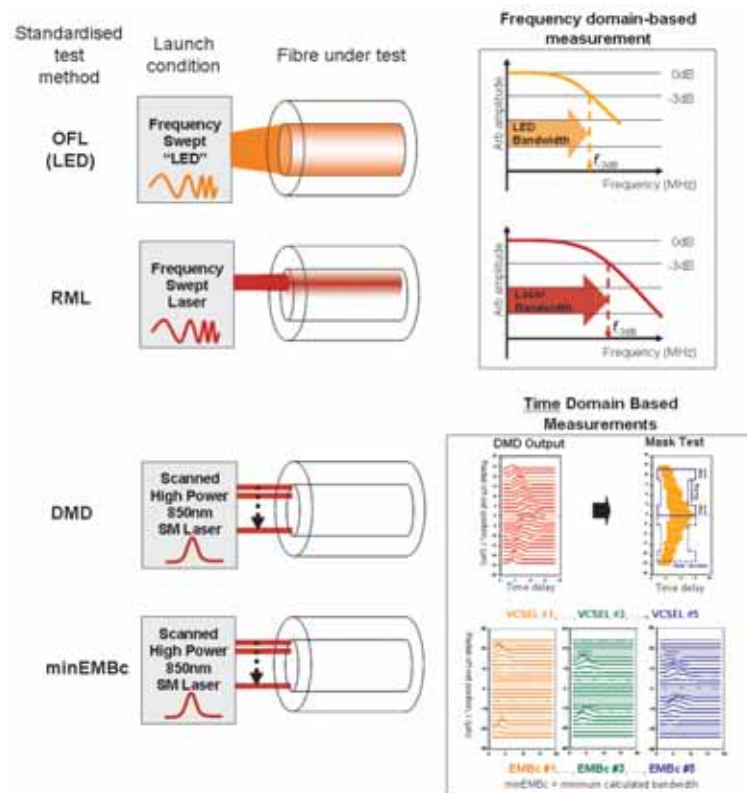

Figure 2 illustrates in simple terms the key principles behind the 4 different multimode fiber bandwidth measurement approaches (OFL, RML, DMD and minEMBc). OFL uses an LED-like launch to “overfill” the core of an LED-optimized multimode fiber. The modulation frequency of the input light signal is then increased until a 3 dB (50%) reduction in transmitted optical power is detected. This upper frequency point is multiplied by the fiber length to determine the normalized bandwidth (MHz.km) and is repeated at both 850 and 1300 nm wavelengths. Unlike laser-optimized multimode - having higher bandwidth at 850 nm to take advantage of VCSEL laser technology - LED-optimized multimode fiber tends to have higher OFL bandwidth at 1300 nm. To accommodate the transition to laser-optimized fibers, RML was introduced using broadly the same detection and measurement technique as OFL. The major difference being that a laser-like launch is created by using a mode conditioning patch-cord (located slightly offset to the core center) to simulate the smaller (restricted) spot size of a laser. This technique can more accurately predict multimode bandwidth when used with lasers operating at typically gigabit speeds.

At higher data rates, for example 10 Gigabits, a more accurate measure of the modal bandwidth properties of the fiber is needed. The introduction of the DMD test method marked the transition to an inherently more complex bandwidth assessment using time domain based analysis of discrete modal output responses to a series single-mode laser launches across the whole cross-section of the core of the fiber. The DMD measurement technique was introduced during the development of the 10 Gigabit Ethernet standard. Consequently the DMD normalized measurement technique and standardized masks will only test the capability of an OM-3 grade fiber^s at 10 Gb/s over the specific 300 meter link distance referenced in the 10 Gigabit Ethernet standard (IEEE 802.3ae). minEMBc built on the DMD concept, incorporating for the first time, the impact of individual VCSEL-based transceiver characteristics on the bandwidth performance of a multimode fiber. minEMBc is a more recently standardized test method used by Corning to obtain a true measure of the bandwidth capability of every fiber. minEMBc is based on the standardized DMD measurement technique, but whereas the DMD normalized-mask method can only provide pass or fail results for a 300 meter target distance, minEMBc can be used to accurately predict a wide range of target link distances below and above 300 meters. In the next sections we will focus in more detail on the DMD-mask method and the minEMBc measurement technique and show how the laser bandwidth predicted by minEMBc can be utilized by systems designers and network engineers.

Outline of standardized bandwidth test techniques for multimode fiber from OFL to minEMBc - reflecting evolution in multimode transceiver technology

Figure 2



DMD-Based Measurements for High Data Rate Applications

Fiber bandwidth measurements cannot be made in the field and so multimode fiber is tested during production, on full reel-length fibers (up to 17.6 km in length). VCSELs do not have enough output power to overcome the attenuation of such long lengths, and so a high power single mode laser source must be used instead.

The DMD test concept was first developed by Corning during the 1970's to analyse modal delay of graded index multimode fibers⁶. The standardised fiber test method for 10 Gigabit Ethernet in 2002 comprises of a high-power 850 nm single-mode laser source with a spot size of about 5 microns. This laser scans across the diameter of the 50 micron multimode fiber under test in steps of 2 microns, Figure 3. At each offset position a short impulse of light is launched in to the fiber. Output responses $U(r,t)$, corresponding to each launch at every offset position, r , are collated to produce a DMD output as illustrated in Figure 3. The DMD output provides a virtual mapping of the individual modal pulse delays within the fiber, represented by the temporal position on the x-axis (time delay) versus the pulse amplitude and radial off-set position plotted on the y-axis (centred relative to the core geometry of the fiber). Hence the DMD technique is capable of obtaining a detailed signature of the modal delay structure of the fiber under test. At this point the recorded output responses are computationally analysed and normalised to 25% of the maximum pulse amplitude. The 25% level defines the start and end position of each pulse for the purpose of applying the test masks. This process effectively discards the upper 75% of the captured data and any informative content therein (see figure 3 where this is illustrated by the effective quantisation of the output waveform). The normalised response is then analysed relative to a series of up to 7 different mask sets, each of which have been empirically derived for 10 Gb/s performance over 300 meters³. Each mask defines a set of fast and slow time-delay boundary conditions relative to the offset position (relative to the centre-line of the fiber) which must be met if the fiber is to pass the test. If the normalised time-delay output responses lie fully within the boundary conditions of at least one of the masks, then the fiber passes the DMD criteria for the 10 Gigabit Ethernet standard for 300 m (10GBASE-SR) operation and an effective modal bandwidth (EMB) of at least 2000 MHz.km is assumed. Although this technique is standardized, we next review the minEMBc measurement approach and highlight advantages over the mask method.

DMD Test Principle (normalized-mask pass/fail method illustrated)

Figure 3

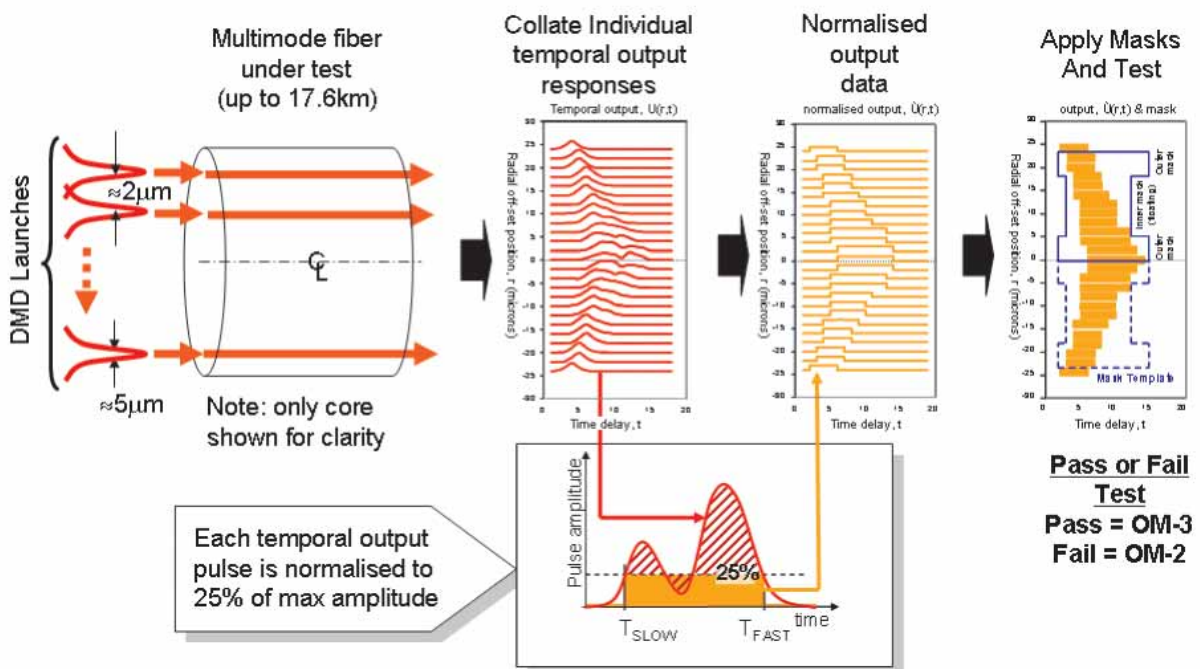

minEMBc – Robust Bandwidth Certification for High Performance Multimode Fiber

The minEMBc measurement method uses high-resolution DMD techniques, including the use of the high power single-mode 850 nm laser source to measure full-reel length fibers (up to 17.6 km) during the manufacture. However, unlike the DMD method, the minEMBc method measures the actual fiber bandwidth performance, recognising the fact that overall system bandwidth is a function of both the bandwidth properties of the fiber and also the particular characteristics of individual laser sources. This is reflected in the way the 10 Gigabit Ethernet standard was developed requiring new specifications for both multimode fiber and laser transmitters. The minEMBc test method utilizes the laser output characteristics of 10 different VCSEL sources⁶, selected by the TIA during the development of the 10 Gigabit Ethernet standard to represent the full range of output power characteristics allowed by the standard. These are used to determine the possible range of fiber– laser bandwidth performances.

Although the precise details are technically complex, the key principle behind the minEMBc measurement method is quite simple. The bandwidth of the fiber is calculated (using DMD-based measurement output data) for each of the 10 different VCSEL–fiber combinations. This is necessary because the standards compliant VCSELs (see appendix A) cover a wide range of emission characteristics that can yield significantly different bandwidth results with each multimode fiber. Of the ten different bandwidth values obtained the lowest value is used to certify the minimum performance (minEMBc) of the fiber and hence guarantee in-field performance with the full range of standards complaint transceivers.

Illustration of the minEMBc measurement used to certify InfiniCor Laser Optimized™ Fibers

Figure 4

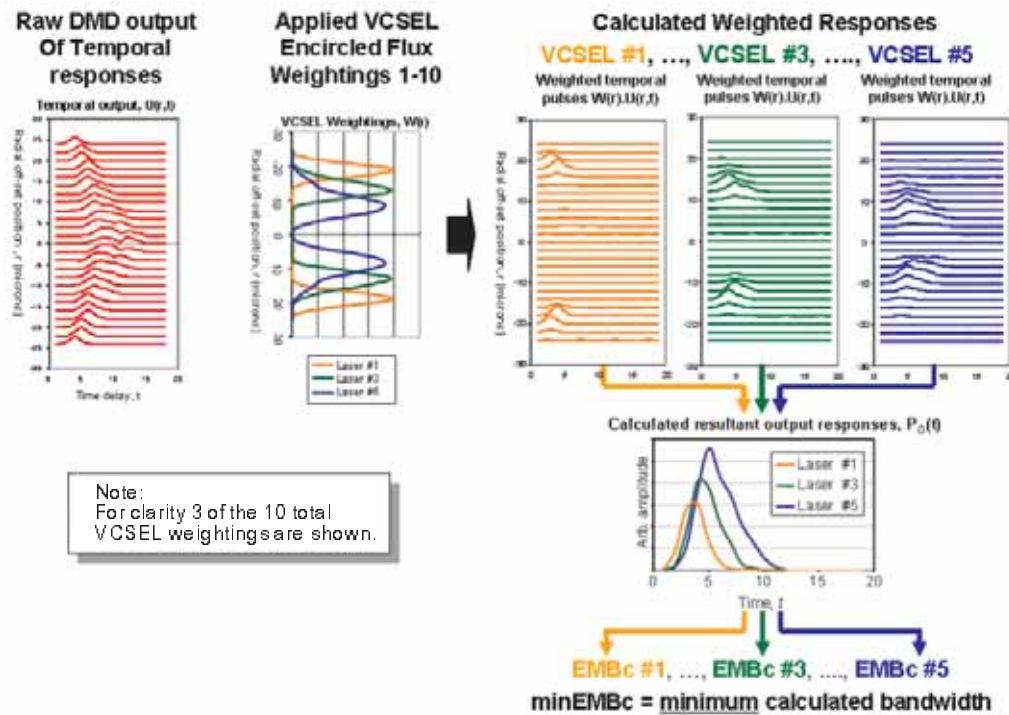

Figure 4, on the left shows the plotted raw output response, $U(r,t)$ from the DMD measurement and adjacent is the VCSEL weightings, $W(r)$ for three of the ten lasers #1, #5 and #10 according to the standard⁴. The off-set weightings for each of light output profiles generated by the 10 VCSEL sources are published in the relevant standards⁴ describing the minEMBc method and obtained using the encircled flux measurement of the VCSEL light output⁷ (described in more detail in appendix A). Figure 4, also shows the calculated DMD output for each of the VCSELs, $W(r).U(r,t)$, made by applying each VCSEL-weighting to the raw DMD measurement output. Each of the calculated VCSEL-DMD responses is then used to calculate the

resultant output responses (Figure 4) which is compared to the original input pulses to back-calculate the bandwidth properties of the fiber. The result of this process yields 10 different calculated effective modal bandwidth (EMBc) values for each fiber tests (given in MHz.km) and thereby mimicking a test in which the 10 VCSEL sources would be used directly. Of the 10 EMBc values the minimum value is selected and is defined as the minimum effective modal bandwidth (known as the minEMBc). The complexities of the precise methods used are beyond the scope of this paper but further details are provided in the Appendix A.

Such is the power and flexibility of the minEMBc method, that the technique is totally scaleable to accommodate alternate data rates and/or other target link distances. The minEMBc method can also be extended to include the effects of other source characteristics such as wavelength and spectral width, allowing it to rapidly adapt to evolving VCSEL and fiber technology. Thus the advantages of the over the DMD-mask method can be summarized;

minEMBc Method used by Corning

- ✓ More robust bandwidth assessment of fiber with all standards complaint transceiver base.
- ✓ Able to measure and record actual laser bandwidth Information – Laser Bandwidth Value.
- ✓ Scaleable measurement for alternative data rates or longer/shorter link distances.
- ✓ Enables visibility of spare margin for system reliability and future upgrades.

DMD Normalized Mask Method

- ✗ DMD method unable to account for different VCSEL characteristics.
- ✗ Pass or fail test for predicted 2000 MHz.km EMB value only.
- ✗ Predicts performance over 300 meters only. No standards mask sets for e.g. 550m.
- ✗ Pass or fail test only.

Corning Laser Bandwidth Certification

Since the inception of the RML standard in 1998 Corning has conducted a laser bandwidth measurement on each and every multimode fiber reel produced within its InfiniCor product range. Starting in 2006, Corning is providing customers with the actual measured laser bandwidth value for each and every multimode fiber in the InfiniCor range. Corning uses the minEMBc method to certify the laser bandwidth for its OM-2, OM-2+, OM-3 and OM-3+ products, InfiniCor 600, InfiniCor SXi, InfiniCor SX+ and InfiniCor eSX+ respectively. For OM-1 products like InfiniCor 300, Corning uses, at a minimum, the RML measurement method. For 10 Gb/s rated performance Corning uses the minEMBc measurement to certify every fiber.

Corning InfiniCor fiber products and laser bandwidth measurement methods

Table 1

Standard Classification	Product	Laser Bandwidth Value (MHz.km @ 850nm)	MMF Type	Primary Laser Bandwidth Measurement Method
“OM-3+”	InfiniCor® eSX+ fiber	4700	50/125 μm	minEMBc ⁴
OM-3	InfiniCor® SX+ fiber	2000	50/125 μm	minEMBc ⁴
“OM-2+”	InfiniCor® SXi fiber	850	50/125 μm	minEMBc ⁴
OM-2	InfiniCor® 600 fiber	510	50/125 μm	minEMBc ⁴
“OM-1+”	InfiniCor® CL™ 1000 fiber	385	62.5/125 μm	RML ²
OM-1	InfiniCor® 300 fiber	220	62.5/125 μm	RML ²

Note: “OM-1+”, “OM-2+” and “OM-3+” are industry terms for enhanced specifications not standardised as per ISO/IEC 11801. Example: InfiniCor eSX+ fibers exceed requirements of the OM-3 standard with higher specified laser bandwidth.

Link Distance Performance from Laser Bandwidth Measurements

The IEEE model is the industry reference point for calculating the maximum achievable Ethernet link distances from known or assumed default transceiver and fiber attributes⁸. The models were central to development of both the Gigabit Ethernet and 10 Gigabit Ethernet standards and set out the minimum requirements of components in an optical link (Figure 6); transceivers, cabled fiber properties and hardware (connectors). As far as the passive optical components are concerned, the laser bandwidth is the most significant factor in determining link performance. Knowing the exact minimum bandwidth performance of each fiber is a prerequisite to understanding the ultimate limitations of any practical system, and thus being able to overcome system penalties and operate reliably at required speeds. The optical power budget of 7.30 dB for a 10GBASE-SR link is assured by standards compliant transceivers meeting the minimum requirements for output power and receiver sensitivity. The insertion loss is the combined attenuation of cabled fiber (3.5 dB/km) over 300 meters and total connector loss of 1.5 dB. Excess fiber bandwidth can provide increased spare system margin, as illustrated in Figure 5, by the example of a high performing OM-3 fiber and hence the models can be used to engineer solutions requiring extended link distances, additional connector pairs and other cable hardware including pre-terminated multi-fiber connections.

IEEE Ethernet link model and link budget values for 300 meters link featuring OM-3 multimode fiber 2000 MHz.km EMB OM-3 fiber

Figure 5

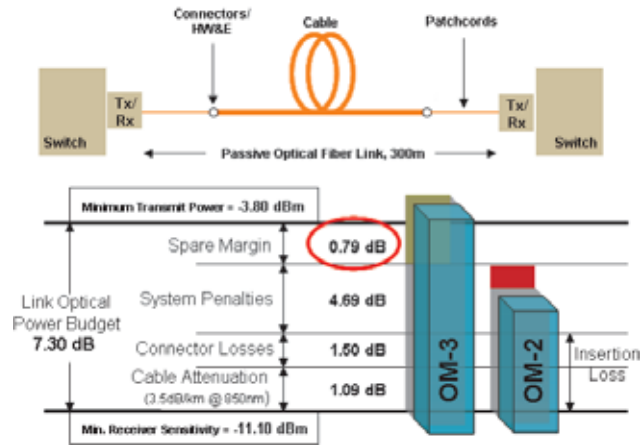

Extended 10Gb/s achievable link distance enabled with InfiniCor fibers

Figure 6

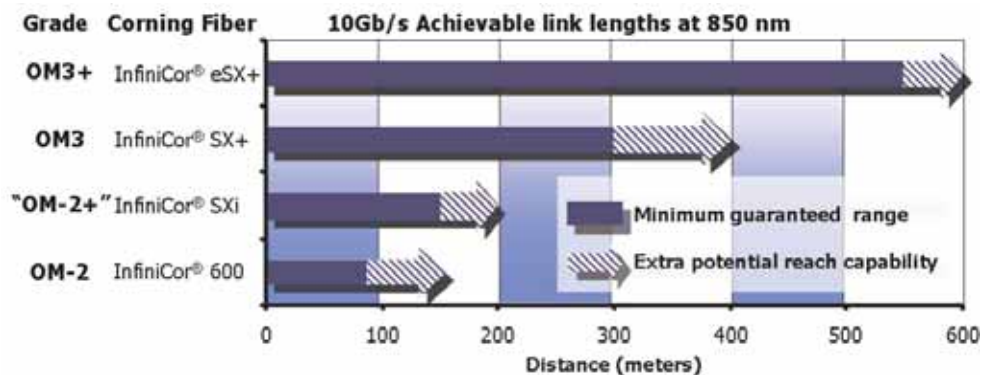

The measured laser bandwidth values for InfiniCor fibers provided by Corning to customers often exceed the minimum bandwidth specifications as required by the relevant Standards. In which case the excess bandwidth can be translated, using the IEEE model, into additional headroom for extended reach, greater operating reliability, or spare system margin for future upgrade paths. Increased spare system margin, enabled by higher bandwidth fibers, can enable the use of additional or innovative cable management hardware (e.g. connectors, multi-fiber terminations) with associated higher insertion losses without compromising system reach. Figure 7, shows the effect on the achievable 10 Gigabit reach when adding further connector pairs, 0.75 dB each, in a addition to standard cabled attenuation, 3.5 dB/km, and default connector budget, 1.5 dB, (InfiniCor eSX+ 550 meter link assumes 3.0 dB/km attenuation and initial connector budget of 1.0 dB). By quoting the actual laser bandwidth value Corning enables the system designers to take advantage of the benefit of higher bandwidth performance wherever possible and deliver cost efficient network designs without compromising system reliability.

Extended 10 Gb/s Ethernet reach and connector/cable hardware flexibility

Figure 7

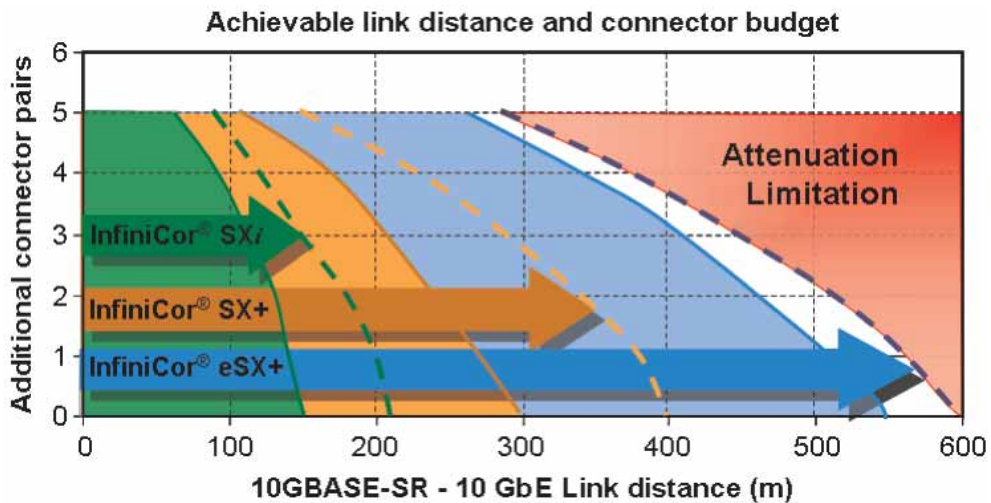

Summary: Corning InfiniCor Laser Optimized™ Multimode Fiber

In this paper we have reviewed laser bandwidth measurement methods reflecting the evolution in transceiver technology keeping pace with demand for increasing data rates. Since Corning introduced the world’s first laser optimized multimode fiber, all InfiniCor products have featured highly accurate graded index profiles that minimise differential modal delay (DMD) across the core of the fiber and thereby optimise system performance. Since transitioning to laser optimized multimode fiber, Corning has insisted on rigorous laser bandwidth measurements (maintaining OFL measurements only for certification with legacy systems using LED transceivers) on every fiber in its InfiniCor product range, in order to ensure robust and future proof field performance. In addition, Corning uses the most sophisticated laser bandwidth measurement, minEMBC, to characterise the laser bandwidth performance of all its InfiniCor products rated for multi-Gigabit operation. The minEMBC method is highly flexible, producing data that is scaleable to data rate and target link distance and therefore enables Corning to offer InfiniCor fibers which are uniquely characterised to support international standards protocols (e.g. Ethernet, Fibre Channel, InfiniBand, etc.) over a range of target link distances not necessarily specified by international standards. The newest and most accurate laser bandwidth measurement metrics coupled with Corning’s leading reputation for the finest quality optical fiber ensure reliable field performance for the most demanding premises network applications.

References

- ¹ Task Force for Modal Dependence of Bandwidth during development of IEEE 802.3 1998.
- ² RML laser bandwidth measurement as per TIA-EIA 455-204 and IEC 60793-1-41.
- ³ DMD Normalized-mask test method for 10 Gigabit Ethernet as per TIA/EIA 455-220 and IEC 60793-1-10.
- ⁴ minEMBc high-performance laser bandwidth measurement as per TIA/EIA 455-220A and IEC 60793-1-49.
- ⁵ Structured Cabling Standards for Premises Cabling Applications ISO/IEC 11801 2nd Edition.
- ⁶ R. Olshansky and S. M. Oaks, "Differential Mode Delay Measurement", ECOC 1978, pp125-130.
- ⁷ Encircled Flux measurement for laser sources as per TIA FOTP 203 and IEC 61280-1-4.
- ⁸ http://www.ieee802.org/3/ae/public/adhoc/serial_pmd/documents/10GEPBud3_1_16a.xls.
- ⁹ InfiniCor Reference Sheet – Product link lengths in common laser-based applications standards, April 2006.

For further information visit the Corning web site: www.corning.com/opticalfiber.

Appendix A

Encircled Flux applied to the minEMBc Measurement Technique

The 10 Gigabit Ethernet standard for the first time included new specifications for both the transceivers and multimode fiber. The broad variation in VCSEL characteristics studied by the TIA during the development of the 803.2ae standard necessitated control over the light intensity output pattern. Although the output emitted from a VCSEL laser is a circular beam the near-field intensity of the light propagating along the fiber is more like a “doughnut-ring” shape, with near zero intensity at the core centreline. The TIA standard governing the encircled flux (EF) light output patterns from VCSEL sources for the 10 Gigabit Ethernet standard, effectively encourages the light to be launched over a wider area of the fiber core, thereby continuing to utilise the larger core diameter advantage of multimode over singlemode fiber to enable lower system costs. Figure 1A on the left, shows a mapping of different VCSELs source output characteristics relative to the boundary conditions of the EF standard. This chart also shows the characteristics of the 10 VCSELs studied by the TIA closely matches by 10 VCSELs sources used at Corning for measurements to determine minEMBc. Figure 1A on the right, shows the corresponding numerical weighting for each of the 10 different VCSELs (studied by the TIA) plotted against the radial off-set position, relative to the centre line of the fiber core. Lasers launching relatively higher proportion of power towards the centre of the core (e.g. laser #1) are referred to as “hot inside” sources. Lasers launching a relatively higher proportion of power into the outer radial of the core (e.g. laser #5) are referred to as “hot outside” sources.

Range of VCSEL sources characterised by EF for the IEEE 802.3ae standard

Figure 1A

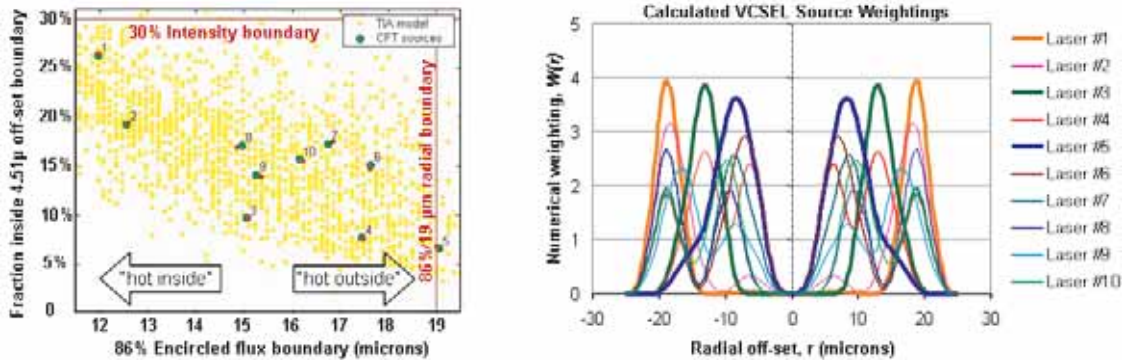

Calculated numerical weighting for a “hot-outside” emission pattern VCSEL source (one of the 10 VCSELs sources)

Figure 2A

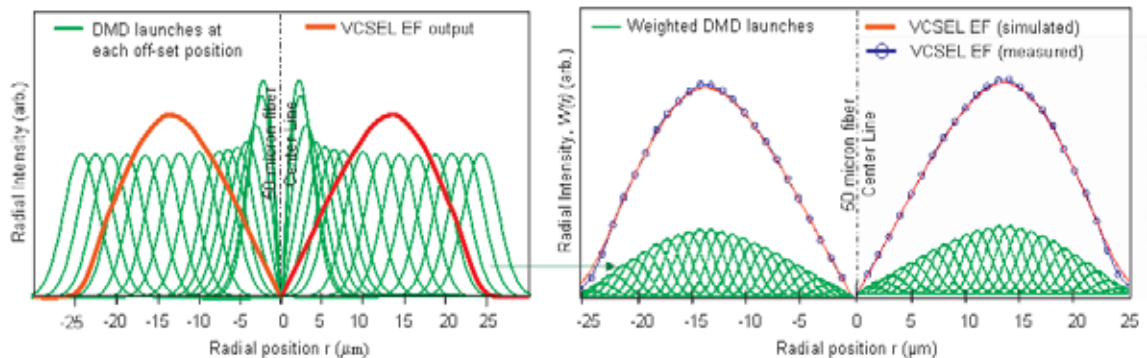

Appendix A

Figure 2A shows an example of how the numerical weighting is obtained from the EF pattern of a “hot-outside” VCSEL in comparison with the DMD laser launches (the relative intensities are not to scale in this chart, given the light intensity of the DMD launch is much higher than the output from a VCSEL). In this example shown demonstrates how this particular laser output characteristic has higher light intensity away from the centre line of the fiber. Each VCSEL numerical weighting is applied in turn to the raw output data obtained from the DMD-minEMBc measurement. This process mimics tests in which the VCSELs themselves are used in the measurement.

The resulting 10 different weighted DMD responses are used to calculate the output impulse response, $PO(t)$ for each of the 10 VCSELs using the numerical weighting, $W(r)$ and the raw DMD output (r,t) ;

$$P_o(t) = \sum_r W(r)U(r,t)$$

The transfer function and therefore the effective modal bandwidth for each of the 10 different VCSEL-fiber combinations can therefore be calculated by taking the Fourier transform (FT) of the 10 resultant outputs, $PO(t)$ and the reference input pulse (generated by the DMD-launch), $R(t)$ bandwidth of each of the;

$$H_{Fiber}(f) = \frac{FT[P_o(t)]}{FT[R(t)]}$$

In other words the time-domain waveforms describing the input and output pulses for each of the 10 VCSELs is used to calculate the bandwidth frequency responses of the fiber. The 10 different EMBc (calculated effective modal bandwidth) values are compared and the lowest numerical value is taken to be the minEMBc value. Hence minEMBc (minimum calculated effective modal bandwidth) certifies the fiber compatible with all standards compliant VCSEL sources.

Corning Incorporated
www.corning.com/opticalfiber

One Riverfront Plaza
Corning, NY 14831
U.S.A.

Phone: 800-525-2524 (U.S. and Canada)
607-248-2000 (International)

Email: cofic@corning.com

Corning and InfiniCor are registered trademarks of Corning Incorporated,
Corning, N.Y.

©2007, Corning Incorporated