

1. COMPONENTS

Number	Components
1	Keep Button (Black)
2	Scrap Button (Red)
3	Cleave Button (Blue)
4	Fiber Handler
5	Latch
6	Strip Length Guide

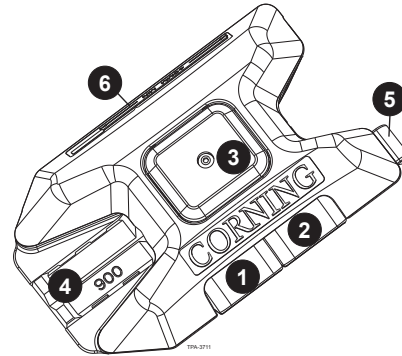

2. FIBER PREPARATION

Step 1: Strip fiber a minimum of 40mm.

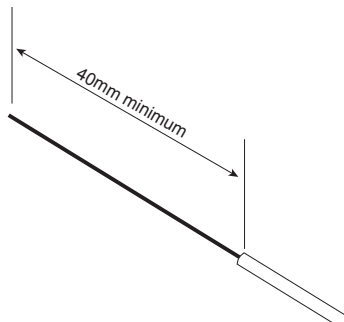

Step 2: Check fiber against strip length guide.

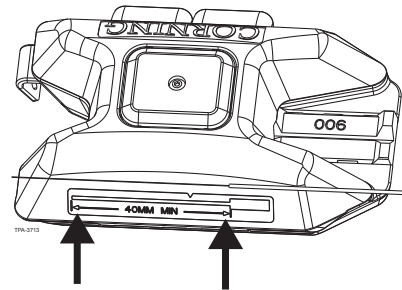

3. CLEAVING 900 MICRON FIBER

Step 1: Depress Black and Red buttons.

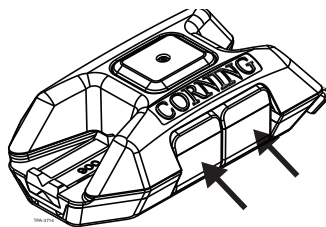

Step 2: Insert fiber until it stops.

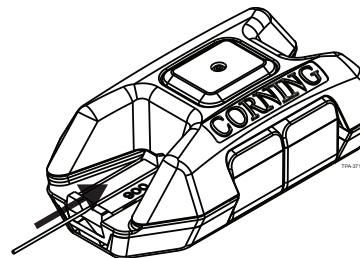

Step 3: Release buttons.

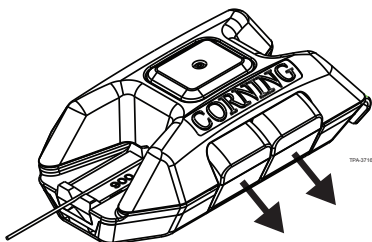

Step 4: Cycle Red button once.

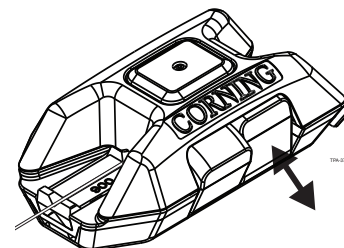

Step 5: Press Blue button.

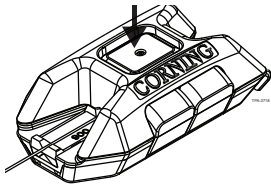

Step 6: Hold fiber and press Black button to remove.

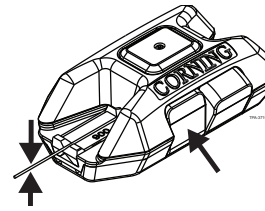

Step 7: Check cleave length against guide.

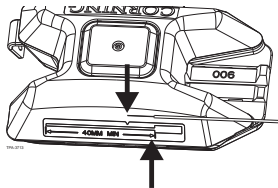

Step 8: Hold scrap fiber and press Red button to remove.

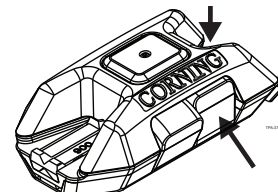

4. CLEAVING JACKETED FIBER

Step 1: Flip fiber handler.

Step 2: Follow Steps 1 through 8 for cleaving 900 micron fiber.

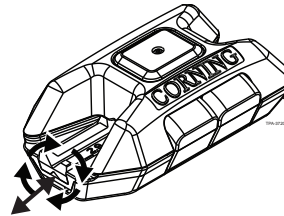

5. CLEAVING FOR 250 MICRON AND OPTISNAP® FANOUT APPLICATIONS

Step 1: Add handler track to cleaver.

a. Remove 900/2.9 handler.

b. Depress latch and lift cover.

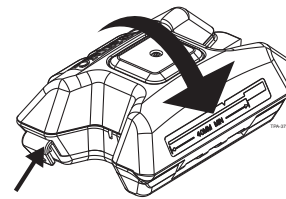
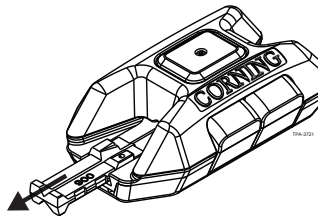

c. Insert handler track.

d. Depress latch while pressing the cover firmly to close.

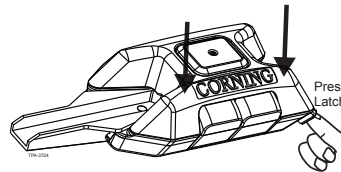
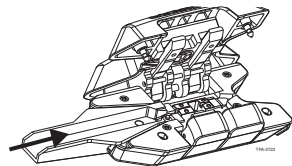

Step 2: Strip fiber and check length against guide.

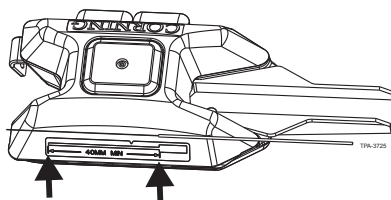

Step 3: Load fiber into fiber handler.
For furcation when using a 250 micron OptiSnap connector (-250 connector part numbers), load fiber into purple OptiSnap fanout handler.

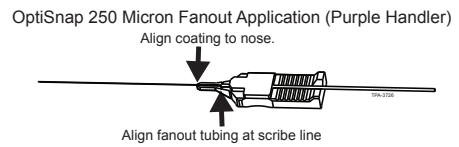

For 250 micron bare fiber installation only using 250 micron OptiSnap connector (-250 connector part numbers), load fiber into gray (or orange) OptiSnap handler.

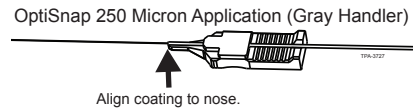

For furcation using 900 micron OptiSnap connectors (-900 connector part numbers), load fiber into blue OptiSnap fanout handler (ordered separately, p/n HAN-FANOUT-UNI).

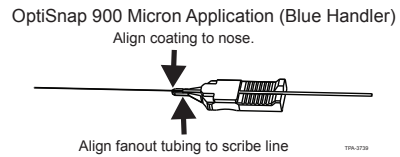

Step 4: Depress Red and Black buttons and load handler with fiber into cleaver.

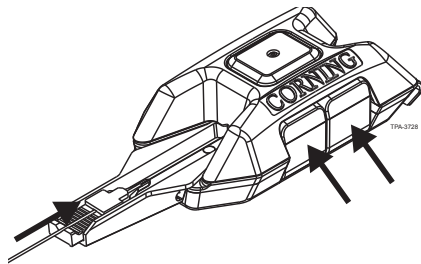

Step 5: Cycle Red button once.

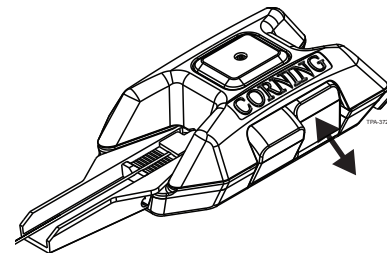

Step 6: Press Blue button.

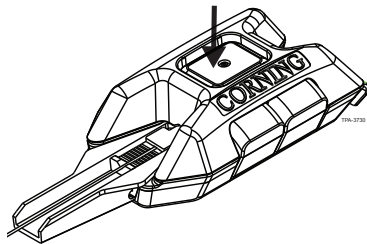

Step 7: Press Black button and slide handler out of the cleaver.

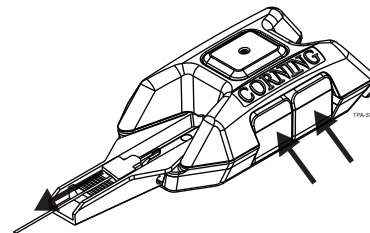

Step 8: Remove fiber from handler and check cleave length against guide.

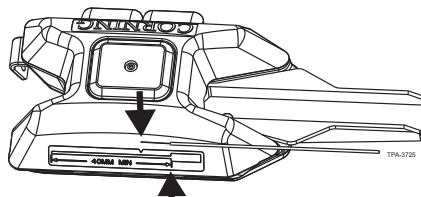

Step 9: Hold scrap fiber and press Red button to remove.

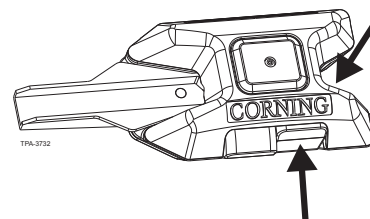

6. TROUBLESHOOTING

Problem	Possible Causes	Solutions (Actions)
Cleaver is producing bad cleaves or breaking fibers.	1. Debris in the clamps	1. Clean the clamps per the instructions.
	2. Blade is worn or damaged.	2. Replace the blade per the instructions.

7. MAINTENANCE

7.1. Opening Cleaver for Cleaning or Maintenance

To open depress latch and lift cover.

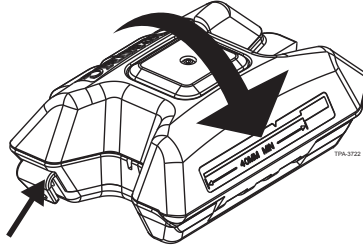

Press firmly to close.

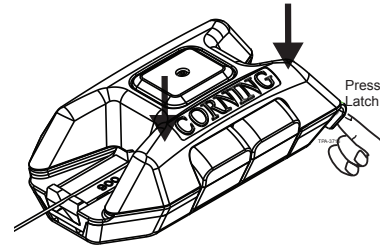

7.2. Cleaning

Wipe three places with fiber wipes and cleaning fluid. Aggressively clean scrap pad if experiencing fiber breaks.

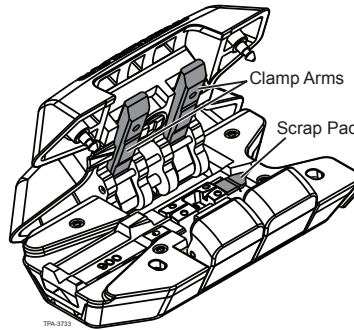

7.3. Replacing Blade

Step 1: Remove two screws, blade block, and blade with blade pin.

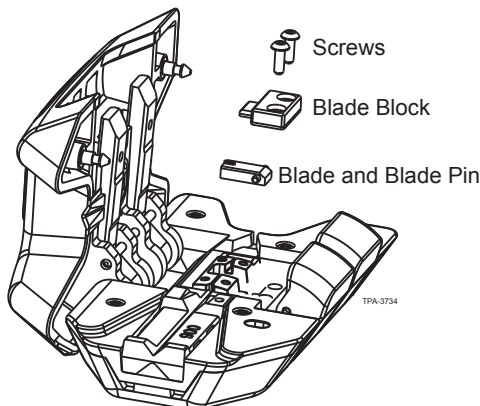

Step 2: Replace blade and reuse blade pin.

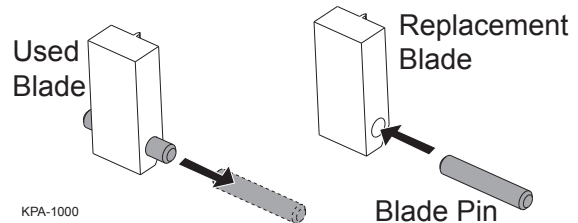

Corning Cable Systems LLC • PO Box 489 • Hickory, NC 28603-0489 USA
 1-800-743-2671 • FAX +1-828-325-5060 • International +1-828-901-5000 • <http://www.corning.com/cablesystems>

Corning Cable Systems reserves the right to improve, enhance, and modify the features and specifications of Corning Cable Systems' products without prior notification. LANscape, OptiSnap, Pretium, and UniCam are registered trademarks of Corning Cable Systems Brands, Inc. All other trademarks are the properties of their respective owners. Corning Cable Systems is ISO 9001 certified.

© 2011 Corning Cable Systems. All rights reserved. Published in the USA.