

CORNING

Multifiber Pushlok™ Cleaning Tool

009-300-AEN, Issue 1

related literature | Search www.corning.com/opcomm. Click on "Resources/Standard Recommended Procedures."

[004-174-AEN](#)

[Installing Multifiber Pushlok™ Trunks and Mating Multifiber Pushlok Connectors](#)

1. General

This procedure describes a general method for using the Evolv® multifiber Pushlok cleaner (pn CLEANER-PUSHLOK-MF). The illustrations below show a pictorial description of the components of the port cleaner and interchangeable tips.

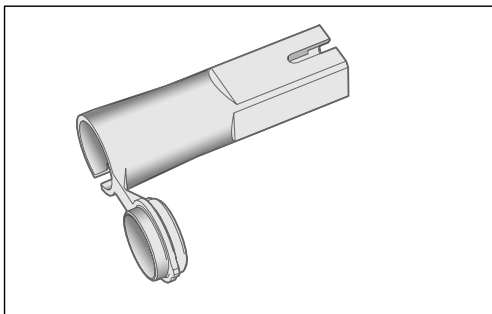
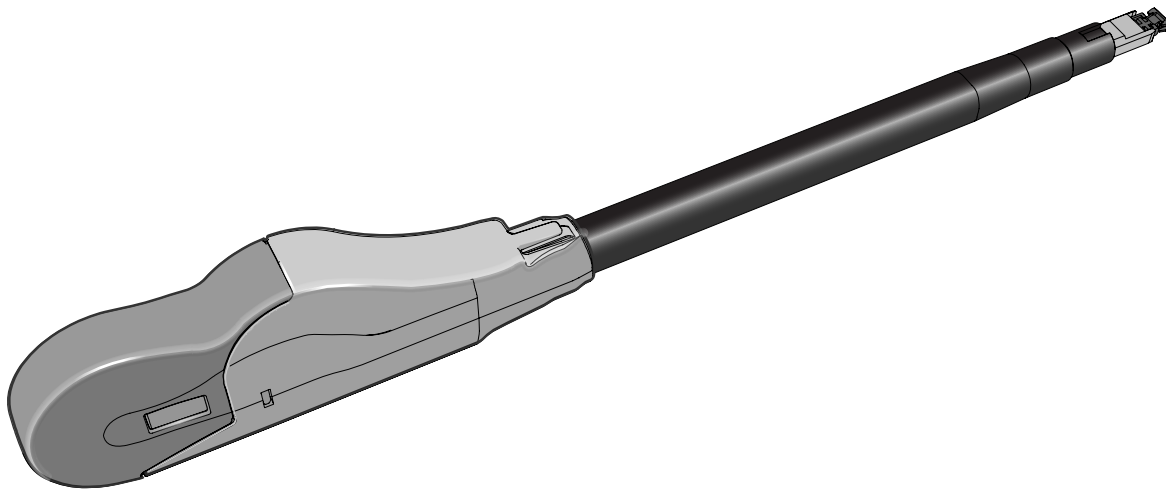

NOTE: Use with non-pinned multifiber Pushlok connector.

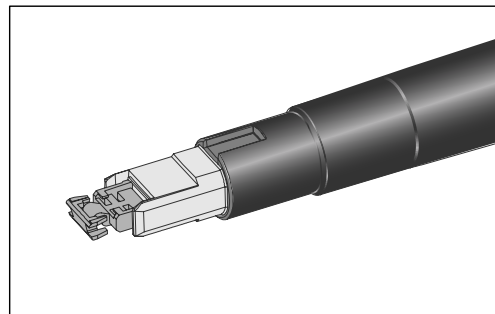

NOTE: Use with pinned multifiber Pushlok connector.

TPA-7969

2. Precautions

2.1 Laser Precautions

	WARNING: Never look directly into the end of a fiber that may be carrying laser light. Laser light can be invisible and can damage your eyes. Viewing it directly does not cause pain. The iris of the eye will not close involuntarily as when viewing a bright light. Consequently, serious damage to the retina of the eye is possible. Should accidental eye exposure to laser light be suspected, arrange for an eye examination immediately.
---	---

2.2 Cable Handling Precautions

NOTE: Fiber optic cable is sensitive to excessive pulling, bending, and crushing forces. Consult the cable specification sheet for the cable you are installing. Do not bend the cable more sharply than the minimum recommended bend radius. Do not apply more pulling force to the cable than specified. Do not crush the cable or allow it to kink. Doing so may cause damage that can alter the transmission characteristics of the cable; the cable may have to be replaced.

2.3 Pushlok™ Assembly Handling Precautions

	CAUTION: Always keep dust caps installed on Pushlok assemblies when they are not in use. Dust and other contaminants on connector end-faces can degrade system performance.
---	--

2.4 Chemical Precautions

When using chemicals, refer to the container or the provided MSDS sheets for precautions specific to each chemical.

3. Cleaning a Multifiber Pushlok Tether or Non-pinned Connector

NOTE: Verify that the Pushlok adapter is installed correctly on the cleaning tool. The key in the adapter should align with the key on the cleaner as shown in the figure below.

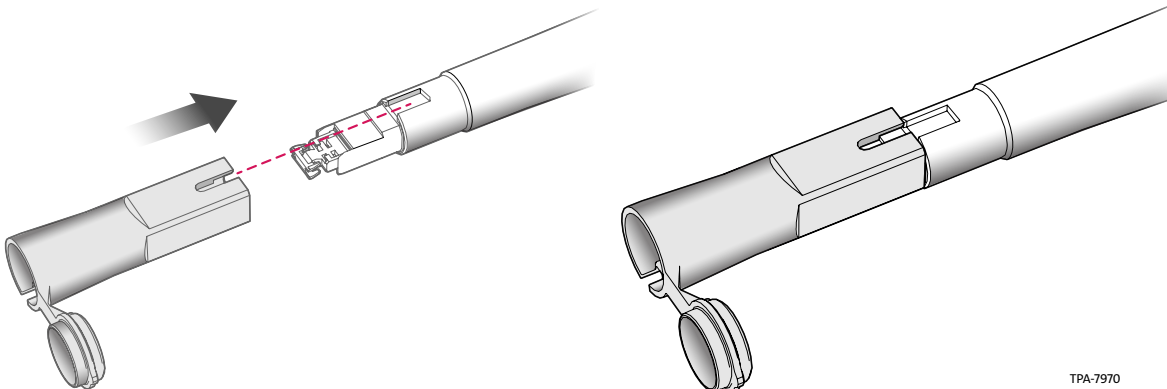



CAUTION: Do not use excessive force during insertion as this may cause damage to both the connector and the tool.

Step 1: Remove the dust cap from the non-pinned connector (SRP 004-174-AEN).

Step 2: Align the keyway on the non-pinned connector with the key on the cleaner adapter. Insert the connector into the cleaner and push until it clicks.

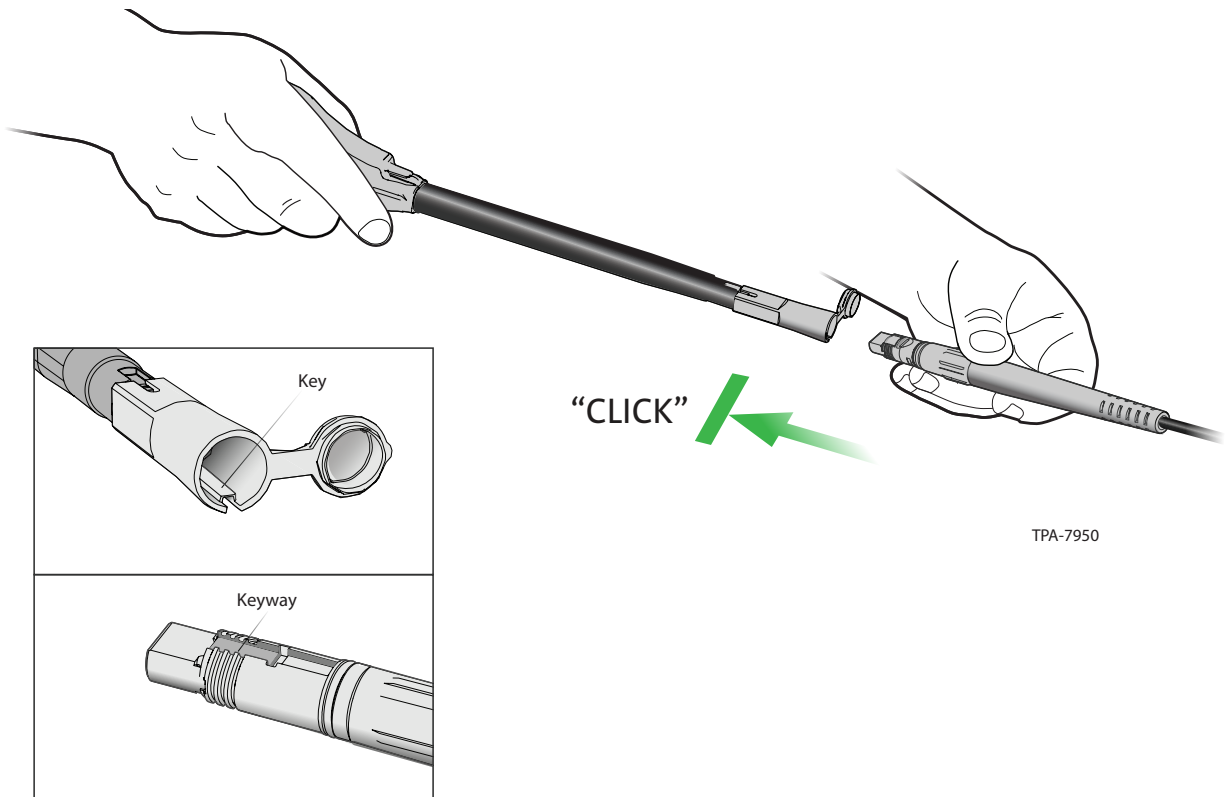

Step 3: Remove the cleaner and replace the connector dust cap.



Step 4: Follow instructions in SRP 004-174-AEN for mating the connectors.

4. Cleaning Multifiber Pushlok™ Terminal Stub or Pinned Connector

Step 1: Remove the dust plug from the pinned connector (See SRP-004-174-AEN).

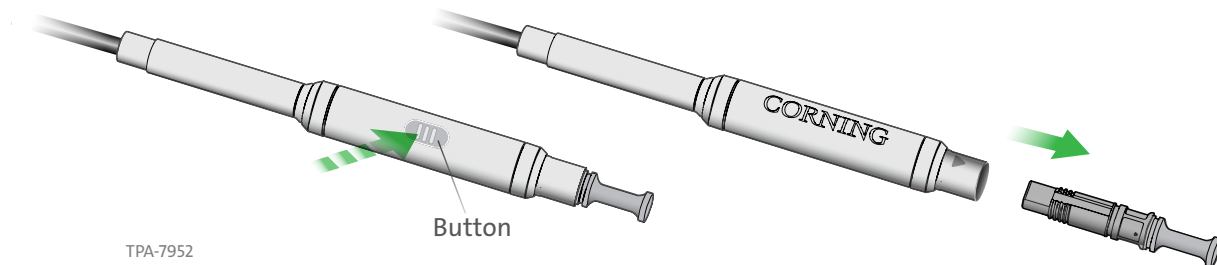

Step 2: Remove the adapter from the end of the cleaner.

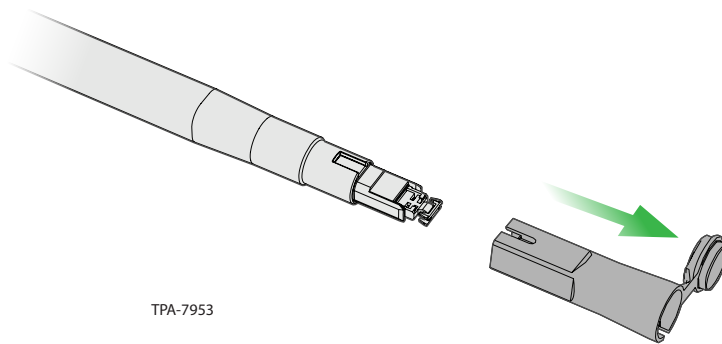

Step 3: Align the groove in the cleaner with the arrow on the connector and insert into the connector. Push on the cleaner until it clicks.

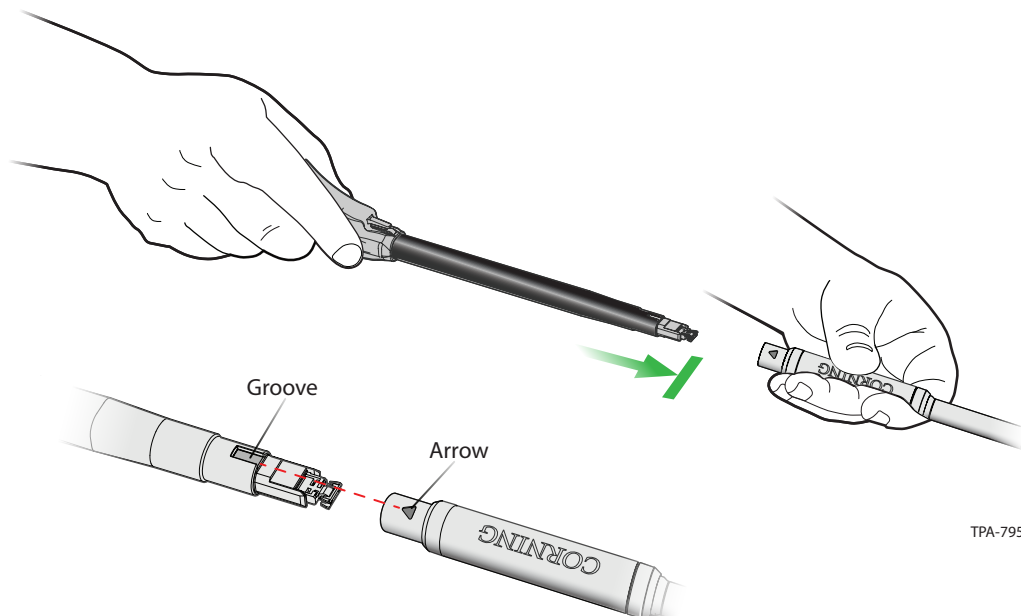

Step 4: Remove the cleaner and replace the connector dust plug.

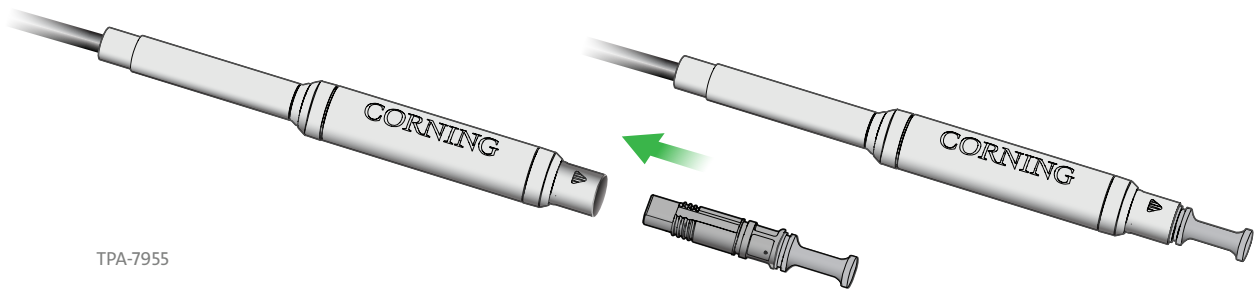

Step 5: Follow instructions in SRP-004-174-AEN for mating the connectors.

5. Cleaning Evolv® Multifiber Pushlok™ Connector Ports

Step 1: Remove the protective plug from the port where the connector will be mated (See SRP-004-174-AEN.)

Step 2: Insert the multifiber port cleaner, until it clicks, to clean the connector inside the port as shown below.

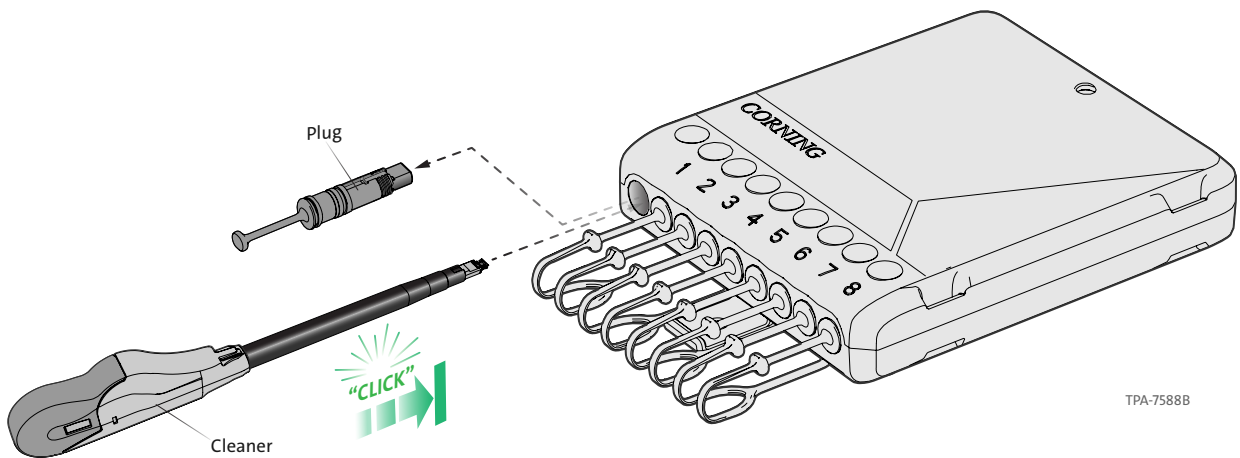

Step 3: Replace the dust plug, or follow the instructions in SRP-004-174-AEN for mating the connectors.