



# Data Center Solutions Brochure



CHATSWORTH  
PRODUCTS

Protecting  
your technology  
investment.

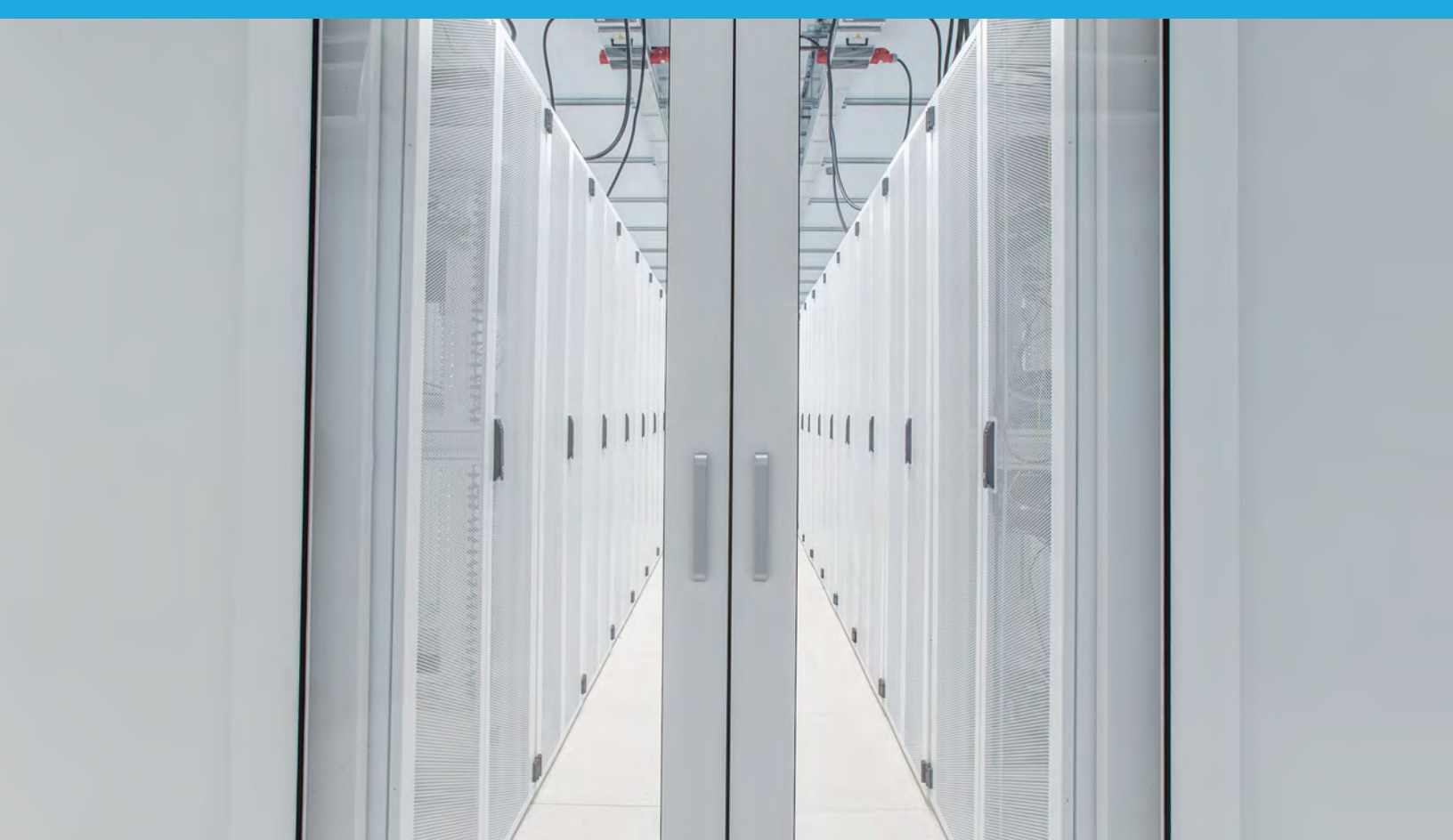

## A Holistic Approach to an Efficient Data Center

In an interconnected world, where organizations use a mix of enterprise-owned and cloud-based services, managing assets and white space remotely has become increasingly important. Chatsworth Products' (CPI) holistic, cabinet-centric approach to the data center simplifies operation, costs and labor, as well as allows for future expansion.

Since 1991, CPI has provided innovative infrastructure solutions that surpass industry standards in quality, flexibility, customization and ease of use. Our commitment to work with data center professionals to provide unique solutions and unparalleled support has resulted in optimized data centers that meet today's and tomorrow's high efficiency standards.

### Availability, Efficiency and Scalability

CPI's cabinet ecosystem is the foundation of a successful data center strategy. This cabinet-level approach allows you to fully utilize each square foot of space— providing both a near-term payback and long-term capacity to grow. CPI's data center cabinet supports equipment, cable management, airflow management, intelligent power distribution, environmental monitoring, physical security and system optimization—a powerful, yet simple concept.

### Upgrade and Retrofit

Aisle-level containment strategies increase efficiency and scalability in both Brownfield and Greenfield applications when cabinet-level isolation is untenable. Developed with built-in flexibility and high-quality engineering, CPI Aisle Containment Solutions easily adapt to challenges such as limited ceiling height and complex overhead pathways. Intelligent power distribution units (PDUs) and standalone electronic locking solutions bring remote power and environmental monitoring to your site while helping you comply with cybersecurity regulations.

### Challenging Applications

Data center professionals are required to meet or exceed the needs of their clients, as well as adhere to industry standards and codes. CPI's extensive experience in data center design has resulted in a portfolio of specialized cabinets to meet unique needs such as seismic environments, side airflow optimization, high densities, and heavy-duty cabinets for shipping fully integrated with equipment.

# CPI Data Center Applications

## Enterprise

Select CPI to partner with you for an efficient, scalable, flexible and cost-effective solution. CPI's integrated solution makes overall deployment and ongoing management much simpler and economical. Thermal management solutions can greatly reduce your cooling cost. Automated monitoring paired with a Data Center Infrastructure Management (DCIM) solution will help you closely monitor your assets and ensure you are optimizing available capacity. Use CPI's electronic access control solutions at the cabinet level to prevent unauthorized physical access, and to provide administrators with an audit trail of all cabinet access for regulatory compliance.

## Colocation / Multitenant Data Centers (MTDC)

Select CPI to support continuous uptime and to provide remote monitoring, asset management and security. Take advantage of the ability to trend power capacity over time to help forecast power consumption more accurately. Use power charge back reporting to closely control power consumption expenses.

## Cloud / Hyperscale

Select CPI for network infrastructure and a single, cost-effective cabinet solution that arrives ready for equipment installation. This allows for rapid growth and network expansion. Our customization capabilities also allow you to specify a unique configuration to match your exact needs.

## Edge

Select CPI to partner with you in your digital transformation. As connectivity evolves to support the Internet of Things (IoT), companies face new challenges with their IT networks extending into manufacturing floors, warehouse and other nontraditional environments. For cleaner environments, use CPI's wall-mounted enclosures to store equipment throughout the office. For dirty, wet environments, CPI offers a full line of NEMA-rated industrial enclosures and accessories such as cooling units and sealing grommets.



# CPI Cabinet Ecosystem

Availability, efficiency and scalability begin within the cabinet ecosystem. This cabinet-centric approach provides equipment support, airflow management, cable management, intelligent power distribution, environmental monitoring, physical security and system optimization.

## Support Equipment

Secure and protect critical equipment in high-density environments.

- Sturdy, deep design
- Supports power, cable and airflow management accessories
- High static load ratings
- Optimal space utilization

## Control Airflow

Reduce cooling costs and manage extreme heat with CPI Passive Cooling® technology.

- Utilizes 100 percent of supplied air
- Supports up to 30kW per cabinet.
- Patented Vertical Exhaust Ducts provide cabinet-level airflow containment

## Organize Cables

CPI's cabinets include specific and physically separate pathways for power and network cables, and mounting locations for power distribution units (PDUs).

- Ensures network integrity with minimal airflow interference.

## Manage Power

Monitor and control power down to the individual device with CPI's intelligent PDUs.

- Rated to withstand high temperatures
- Secure Array® IP Consolidation links 32 PDUs under a single IP connection
- Outlet-level monitoring and switching
- Branch circuit monitoring ensures power availability and prevents overcurrent.





### Monitor Environment

Ensure your equipment is safe from critical environmental conditions with CPI's environmental sensors and probes.

- Measure and track inlet and outlet temperature, and inlet humidity at each rack/cabinet
- Integrate environmental monitoring with intelligent PDUs
- Remotely monitor and log power usage, temperature and humidity thresholds through a user-friendly web interface.

### Protect Equipment

Protect critical equipment and data with CPI's effective, yet simple, electronic access control solutions.

- Remotely control cabinet access attempts through a user-friendly web interface
- Keep audit trails for regulatory compliance
- Networked locks can be powered and networked through our PDUs, or used as a standalone solution
- Add dual-factor biometric authentication with access cards that have built in fingerprint readers

### Optimize System

Visualize trends of all activities in the room and cabinet in a single screen with CPI's simple, yet robust, DCIM software.

- Data charting of trends provides immediate status and insight into utilization
- Power capacity trend analysis provides estimated lifespan
- Power charge back reports allocate power use by equipment, rack or customer
- Failover reports ensure available power on A and B circuits
- Access reports list access by user for each cabinet

### Simplify Operations

- Easily order CPI cabinets with PDUs and accessories preinstalled for quick, simple deployment from a single vendor.

# End-to-End Solutions

The next step to continued efficiency requires the focus to be on the data center as a whole.

Our room-level solutions include:

## Aisle Containment

From a variety of airflow management accessories, to patented Vertical Exhaust Duct for the cabinet, to Hot and Cold Aisle Containment, we have a solution that fits your unique need and architectural challenge.

## Cable Pathway

Variety of options and accessories can be tailored to meet your facility's requirements and are adaptable for future growth.

## Bonding Busbars

CPI offers a comprehensive line of UL® Listed bonding products to protect sensitive electronic equipment.

## Seismic Bracing

Specialty protection systems that help reduce the risk of equipment damage from seismic events.

## Wire Cage Enclosures

Economical physical protection for equipment in shared facility spaces, entrance facilities and equipment rooms are available.



CPI offers complete product information, design tools and other resources to help you easily and efficiently plan and design projects to meet your deadlines and requirements. Visit [www.chatsworth.com/support-downloads](http://www.chatsworth.com/support-downloads)



## How Do You Benefit from CPI's Data Center Solutions?

### Reducing Cooling Costs

- Realize a potential 90% reduction in cooling and energy costs
- Support 4x higher heat and power densities
- Design for future growth
- Lower construction costs relative to active cooling solutions
- Have higher Delta T's ( $\Delta T$ 's) between the data center cooling air and exhaust air to improve the efficiency of CRAC units
- Minimize environmental impact and support green initiatives

### Maximized Space Utilization

- Deploy the latest servers, switches and blade servers from leading manufacturers

### Site Optimization and Regulatory Compliance

- Reduce network connection cost using CPI's Secure Array IP Consolidation technology
- Provide a single integrated system for power management, environmental monitoring and physical security
- Simplify operations with the ability to discover and centrally manage all supported equipment
- Optimize key performance metrics such as Power Usage Effectiveness (PUE), power capacity planning and reporting

### Standardization and Rapid Deployment

- Customize a solution to meet unique applications
- Enable easy ordering and delivery with factory-assembled cabinet solution
- Increase confidence with pre- and post-sale services, industry-leading warranties and more

## US & Canada

+1-800-834-4969

Toronto, Ontario, Canada

+905-850-7770

[chatsworth.com](http://chatsworth.com)

## Latin America

+52-55-5203-7525

Toll Free within Mexico

01-800-01-7592

[chatsworth.com.co](http://chatsworth.com.co)

## Europe

+44-1628-524-834

[chatsworth.com](http://chatsworth.com)

## Middle East & Africa

Dubai, UAE

+971-4-2602125

[chatsworth.ae](http://chatsworth.ae)

## Asia Pacific

+86 21 6880-0266

[chatsworth.com.cn](http://chatsworth.com.cn)

Find more information  
about CPI Solutions at:

[www.chatsworth.com](http://www.chatsworth.com)

+1-800-834-4969 (U.S. & Canada)

or [techsupport@chatsworth.com](mailto:techsupport@chatsworth.com)

## Manufacturing Capability and Global Availability

Headquartered in the United States, CPI operates from multiple sites worldwide, including offices in Mexico, Canada, China, the United Arab Emirates and the United Kingdom. CPI's manufacturing facilities are located in the United States, Asia and Europe.

With stock availability, and CPI's consistently short factory lead times, you can be assured that CPI solutions will be accessible to meet your project scheduling needs.

## How to Buy

CPI sales are conducted in partnership with a global network of distributors, contractors and resellers to ensure a high level of stock availability. Use CPI's Online Catalog to place an order with a distributor near you. CPI has a high level of stock availability. Go to <http://www.chatsworth.com/how-to-buy/> to learn more.

## About CPI

CPI, a 100-percent employee-owned company, was founded in June 1991, when 90 workers joined together and purchased the Dracon Division of Harris Corporation using an Employee Stock Ownership Plan (ESOP). Employee ownership is central to the success of CPI. Employee owners are committed to a philosophy of quality through teamwork, caring and commitment, which are extended to customers through our solutions and services.

## The CPI Total Solution Includes

- Cabinet, Containment & Enclosure Systems
- Cable Management
- Cable Runway & Tray
- Environmental Monitoring & Security
- Grounding & Bonding
- Industrial Enclosure Systems
- Power Management Products
- Rack Systems
- Wall-Mount Systems
- Zone Cabling & Wiring Enclosures

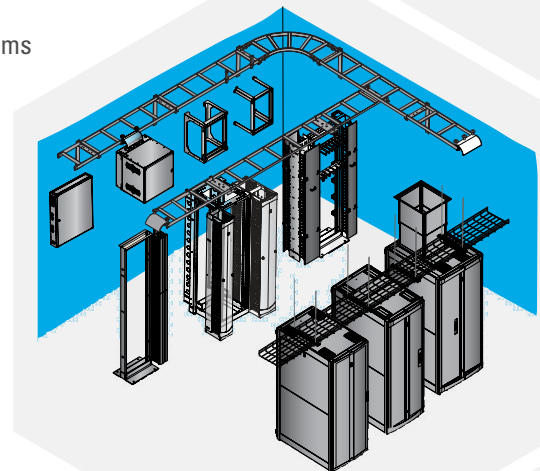

CHATSWORTH  
PRODUCTS



CPI now offers Extended Limited Warranties on CPI-Branded Electronic products, available for two additional years beyond the expiration of the Original Warranty Period (3 years).

Contact CPI Customer Service, or visit [www.chatsworth.com/warranty](http://www.chatsworth.com/warranty) for more information.

While every effort has been made to ensure the accuracy of all information, CPI does not accept liability for any errors or omissions and reserves the right to change information and descriptions of listed services and products.

©2018 Chatsworth Products, Inc. All rights reserved. Chatsworth Products, Clik-Nut, CPI, CPI Passive Cooling, eConnect, Evolution, GlobalFrame, MegaFrame, Motive, OnTrac, QuadraRack, RMR, Saf-T-Grip, Secure Array, SeismicFrame, SlimFrame, TeraFrame and Velocity are federally registered trademarks of Chatsworth Products. CUBE-iT, EuroFrame and Simply Efficient are trademarks of Chatsworth Products. All other trademarks belong to their respective companies. Rev.5 05/18 MKT-60020-312